



User Manual

GeoMax Zenith60 Pro Series

English

Version 1.0

Introduction

Purchase

Congratulations on the purchase of the GeoMax Zenith60 Pro Smart Antenna.



This manual contains important safety directions as well as instructions for setting up the product and operating it. Refer to [1 Safety Directions](#) for further information.

Read carefully through the User Manual before you install and switch on the product.



The content of this document is subject to change without prior notice. Ensure that the product is used in accordance with the latest version of this document.

Updated versions are available for download at the following Internet address:

<https://geomax-positioning.com/partner-area>

Product identification

The model and serial number of your product are indicated on the type plate.

Always refer to this information when you contact your agency or GeoMax authorised service workshop.

Trademarks



- Windows® is a registered trademark of Microsoft Corporation in the United States and other countries
- Bluetooth® is a registered trademark of Bluetooth SIG, Inc.
- microSD Logo is a trademark of SD-3C, LLC.

All other trademarks are the property of their respective owners.

Validity of this manual

This manual applies to the Zenith60 Pro GNSS smart antenna instrument.

Available documentation

Name	Description/Format		
Zenith60 Pro Quick Guide	Provides an overview of the product together with technical data and safety directions. Intended as a quick reference guide.	✓	✓
Zenith60 Pro User Manual	All instructions required in order to operate the product to a basic level are contained in the User Manual. Provides an overview of the product together with technical data and safety directions.	-	✓

GeoMax Technical Library

Refer to the Technical Library web page for all GeoMax Zenith60 Pro documentation and software:

- <https://portal.hexagon.com/>

GeoMax Technical Library offers a wide range of services and information. With direct access to GeoMax Technical Library, you are able to access all relevant services whenever it is convenient for you.



The availability of services depends on the instrument model.



Table of Contents

1	Safety Directions	4
1.1	General Introduction	4
1.2	Definition of Use	4
1.3	Limits of Use	5
1.4	Responsibilities	5
1.5	Hazards of Use	5
	1.5.1 Charger and Batteries	8
1.6	Electromagnetic Compatibility (EMC)	10
2	Description of the System	12
2.1	System Components	12
2.2	Container Contents	12
2.3	System Concept	13
	2.3.1 Software Concept	13
	2.3.2 Power Concept	13
	2.3.3 Data Storage Concept	13
2.4	Instrument Components	13
2.5	Pin Assignments	13
2.6	The Antenna Reference Plane, ARP	15
3	User Interface	16
3.1	Keyboard	16
3.2	LED Indicators	16
4	Operation	18
4.1	Equipment Setup	18
	4.1.1 Setting up as a Real-Time Base	18
	4.1.2 Setting up as a Post-Processing Base	19
	4.1.3 Setting Up as a Real-Time Rover	20
	4.1.4 Pole holder assembly	21
	4.1.5 Connecting to a Personal Computer	21
	4.1.6 Zenith60 Pro WebManager	22
4.2	Batteries	23
	4.2.1 Operating Principles	23
	4.2.2 Insert and Remove the Battery	23
4.3	Inserting a microSD/SIM Card	24
4.4	Working with the Tilt Compensation	25
4.5	Guidelines for Correct Results with GNSS Surveys	28
4.6	Recovery Process	29
5	Care and Transport	30
5.1	Transport	30
5.2	Storage	30
5.3	Cleaning and Drying	30
6	Technical Data	31
6.1	Technical Data	31
	6.1.1 Tracking Characteristics	31
	6.1.2 Accuracy	31
	6.1.3 GNSS antenna specifications	32
	6.1.4 Internal devices	32
	6.1.5 Technical Data	32
6.2	Environmental specifications	33
6.3	Conformity to National Regulations	34
6.4	Dangerous Goods Regulations	36

1 Safety Directions

1.1 General Introduction

Description

The following directions enable the person responsible for the product, and the person who actually uses the equipment, to anticipate and avoid operational hazards.

The person responsible for the product must ensure that all users understand these directions and adhere to them.

About warning messages





Warning messages are an essential part of the safety concept of the instrument. They appear wherever hazards or hazardous situations can occur.

Warning messages...

- make the user alert about direct and indirect hazards concerning the use of the product.
- contain general rules of behaviour.

For the users' safety, all safety instructions and safety messages shall be strictly observed and followed! Therefore, the manual must always be available to all persons performing any tasks described here.

DANGER, WARNING, CAUTION and **NOTICE** are standardised signal words for identifying levels of hazards and risks related to personal injury and property damage. For your safety, it is important to read and fully understand the following table with the different signal words and their definitions! Supplementary safety information symbols may be placed within a warning message as well as supplementary text.

Type	Description
	Indicates an imminently hazardous situation which, if not avoided, will result in death or serious injury.
	Indicates a potentially hazardous situation or an unintended use which, if not avoided, could result in death or serious injury.
	Indicates a potentially hazardous situation or an unintended use which, if not avoided, may result in minor or moderate injury.
	Indicates a potentially hazardous situation or an unintended use which, if not avoided, may result in appreciable material, financial and environmental damage.
	Important paragraphs which must be adhered to in practice as they enable the product to be used in a technically correct and efficient manner.

1.2 Definition of Use

Intended use

- Computing with software
- Recording measurements
- Carrying out measurement tasks using various GNSS measuring techniques
- Recording GNSS and point related data
- Remote control of product
- Data communication with external appliances
- Measuring raw data and computing coordinates using carrier phase and code signal from GNSS satellites (GNSS systems)

Reasonably foreseeable misuse

- Use of the product without instructions
- Use outside of the intended use and limits
- Disabling of safety systems
- Removal of hazard notices
- Opening the product using tools, for example a screwdriver, unless this is permitted for certain functions
- Modification or conversion of the product
- Use after misappropriation
- Use of products with recognisable damage or defects
- Use with accessories from other manufacturers without the prior explicit approval of GeoMax
- Inadequate safeguards at the working site
- Controlling of machines, moving objects or similar monitoring applications without additional control and safety installations

1.3

Limits of Use

Environment

Suitable for use in an atmosphere appropriate for permanent human habitation. Not suitable for use in aggressive or explosive environments.

 **WARNING**

Working in hazardous areas or close to electrical installations or similar situations

Life Risk.

Precautions:

- ▶ Local safety authorities and safety experts must be contacted by the person responsible for the product before working in such conditions.

1.4

Responsibilities

Manufacturer of the product

GeoMax AG, CH-9443 Widnau, hereinafter referred to as GeoMax, is responsible for supplying the product, including the user manual and original accessories, in a safe condition.

Person responsible for the product

The person responsible for the product has the following duties:

- To understand the safety instructions on the product and the instructions in the User Manual
- To ensure that the product is used in accordance with the instructions
- To be familiar with local regulations relating to safety and accident prevention
- To stop operating the system and inform GeoMax immediately if the product and the application become unsafe
- To ensure that the national laws, regulations and conditions for the operation of the product are respected

1.5

Hazards of Use

 **WARNING**

Distraction/loss of attention

During dynamic applications, for example stakeout procedures, there is a danger of accidents occurring if the user does not pay attention to the environmental conditions around, for example obstacles, excavations or traffic.

Precautions:

- ▶ The person responsible for the product must make all users fully aware of the existing dangers.

 **WARNING**

Inadequate securing of the working site

This can lead to dangerous situations, for example in traffic, on building sites and at industrial installations.

Precautions:

- ▶ Always ensure that the working site is adequately secured.
- ▶ Adhere to the regulations governing safety, accident prevention and road traffic.

WARNING

Lightning strike

If the product is used with accessories, for example masts, staffs, poles, you may increase the risk of being struck by lightning.

Precautions:

- ▶ Do not use the product in a thunderstorm.

CAUTION

Not properly secured accessories

If the accessories used with the product are not properly secured and the product is subjected to mechanical shock, for example blows or falling, the product may be damaged or people can sustain injury.

Precautions:

- ▶ When setting up the product, make sure that the accessories are correctly adapted, fitted, secured, and locked in position.
- ▶ Avoid subjecting the product to mechanical stress.

DANGER

Risk of electrocution

Because of the risk of electrocution, it is dangerous to use poles, levelling staffs and extensions in the vicinity of electrical installations such as power cables or electrical railways.

Precautions:

- ▶ Keep at a safe distance from electrical installations. If it is essential to work in this environment, first contact the safety authorities responsible for the electrical installations and follow their instructions.



DANGER

Risk of being struck by lightning

If the product is used with accessories, for example on masts, staffs, poles, you may increase the risk of being struck by lightning. Danger from high voltages also exists near power lines. Lightning, voltage peaks, or the touching of power lines can cause damage, injury and death.

Precautions:

- ▶ Do not use the product in a thunderstorm as you can increase the risk of being struck by lightning.
- ▶ Be sure to remain at a safe distance from electrical installations. Do not use the product directly under or close to power lines. If it is essential to work in such an environment contact the safety authorities responsible for electrical installations and follow their instructions.
- ▶ If the product has to be permanently mounted in an exposed location, it is advisable to provide a lightning conductor system. A suggestion on how to design a lightning conductor for the product is given below. Always follow the regulations in force in your country regarding grounding antennas and masts. These installations must be carried out by an authorised specialist.
- ▶ To prevent damages due to indirect lightning strikes (voltage spikes) cables, for example for antenna, power source or modem should be protected with appropriate protection elements, like a lightning arrester. These installations must be carried out by an authorised specialist.
- ▶ If there is a risk of a thunderstorm, or if the equipment is to remain unused and unattended for a long period, protect your product additionally by unplugging all systems components and disconnecting all connecting cables and supply cables, for example, instrument - antenna.

Lightning conductors

Suggestion for design of a lightning conductor for a GNSS system:

1. On non-metallic structures
Protection by air terminals is recommended. An air terminal is a pointed solid or tubular rod of conducting material with proper mounting and connection to a conductor. The position of four air terminals can be uniformly distributed around the antenna at a distance equal to the height of the air terminal.
The air terminal diameter should be 12 mm for copper or 15 mm for aluminium. The height of the air terminals should be 25 cm to 50 cm. All air terminals should be connected to the down conductors. The diameter of the air terminal should be kept to a minimum to reduce GNSS signal shading.
2. On metallic structures
Protection is as described for non-metallic structures, but the air terminals can be connected directly to the conducting structure without the need for down conductors.

Air terminal arrangement, plan view

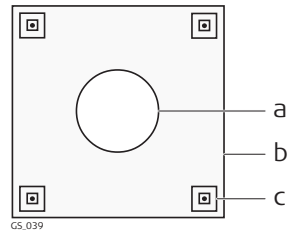

- a Antenna
- b Support structure
- c Air terminal

Grounding the instrument/antenna

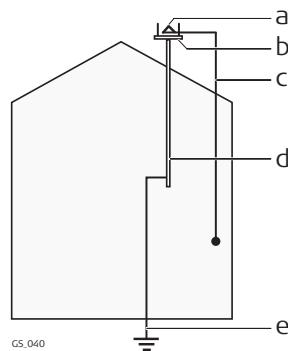

- a Antenna
- b Lightning conductor array
- c Antenna/instrument connection
- d Metallic mast
- e Connection to earth

WARNING

Incorrect fastening of the external antenna

Incorrect fastening of the external antenna to vehicles or transporters poses the risk of the equipment being broken by mechanical influence, vibration or airstream. This may result in accident and physical injury.

Precautions:

- ▶ Attach the external antenna professionally. The external antenna must be secured additionally, for example by use of a safety cord. Ensure that the mounting device is correctly mounted and able to carry the weight of the external antenna (>1 kg) safely.

⚠ WARNING

If the product is improperly disposed of, the following can happen:

- If polymer parts are burnt, poisonous gases are produced which may impair health.
- If batteries are damaged or are heated strongly, they can explode and cause poisoning, burning, corrosion or environmental contamination.
- By disposing of the product irresponsibly you may enable unauthorised persons to use it in contravention of the regulations, exposing themselves and third parties to the risk of severe injury and rendering the environment liable to contamination.

Precautions:

▶



The product must not be disposed with household waste. Dispose of the product appropriately in accordance with the national regulations in force in your country. Always prevent access to the product by unauthorised personnel.

Product-specific treatment and waste management information is available from GeoMax AG.

⚠ WARNING

Improperly repaired equipment

Risk of injuries to users and equipment destruction due to lack of repair knowledge.

Precautions:

- ▶ Only authorised GeoMax Service Centres are entitled to repair these products.

1.5.1

Charger and Batteries

For the AC/DC power supply:

⚠ WARNING

Electric shock due to missing ground connection

If unit is not connected to ground, death or serious injury can occur.

Precautions:

- ▶ The power cable and power outlet must be grounded!



For the AC/DC power supply and the battery charger:

⚠ WARNING

Electric shock due to use under wet and severe conditions

If unit becomes wet, it may cause you to receive an electric shock.

Precautions:

- ▶ If the product becomes humid, it must not be used!
- ▶ Use the product only in dry environments, for example in buildings or vehicles.



- ▶ Protect the product against humidity.

For the AC/DC power supply and the battery charger:

 **WARNING**

Unauthorised opening of the product

Either of the following actions may cause you to receive an electric shock:

- Touching live components
- Using the product after incorrect attempts were made to carry out repairs.

Precautions:

- ▶ Do not open the product!
- ▶ Only authorised GeoMax Service Centres are entitled to repair these products.

 **WARNING**

Inappropriate mechanical influences to batteries

During the transport, shipping or disposal of batteries it is possible for inappropriate mechanical influences to constitute a fire hazard.

Precautions:

- ▶ Before shipping the product or disposing it, discharge the batteries by the product until they are flat.
- ▶ When transporting or shipping batteries, the person in charge of the product must ensure that the applicable national and international rules and regulations are observed.
- ▶ Before transportation or shipping, contact your local passenger or freight transport company.

 **WARNING**

Short circuit of battery terminals

If battery terminals are short circuited e.g. by coming in contact with jewellery, keys, metallised paper or other metals, the battery can overheat and cause injury or fire, for example by storing or transporting in pockets.

Precautions:

- ▶ Make sure that the battery terminals do not come into contact with metallic/conductive objects.

 **WARNING**

Exposure of batteries to high mechanical stress, high ambient temperatures or immersion into fluids

This can cause leakage, fire or explosion of the batteries.

Precautions:

- ▶ Protect the batteries from mechanical influences and high ambient temperatures.
- ▶ Consider the products IP class restrictions in chapter [6.2 Environmental specifications](#).
- ▶ Do not drop or immerse the product into fluids.

 **WARNING**

Wet or moisture conditions

The housing around the battery has wiring which may produce a short-circuit.

Precautions:

- ▶ Do not place the battery system in water or expose it to moisture, lubricants, solvents or any other liquid.

 **WARNING**

Incorrect battery mounting

Wrong mounting of the battery increases the risk of fire, electric shock and damage.

Precautions:

- ▶ Mount the battery in horizontal position.
- ▶ Secure the battery in order to prevent slipping and tilting.

 **WARNING**

Damaged battery

If batteries are damaged or are heated strongly, they can explode and cause poisoning, burning, corrosion or environmental contamination.

Precautions:

- ▶ Protect the battery against mechanical damages.

 **WARNING**

Damaged battery housing

There is a risk of fire. In case skin or eyes have come into direct contact with electrolytes leaking from the battery, rinse them thoroughly with clear water. Immediately contact a doctor.

Precautions:

- ▶ Stop using the battery.
- ▶ Turn off any charging in action.
- ▶ If any electrolytes should leak from a damaged battery, avoid skin contact and direct inhalation of gases.

 **WARNING**

Hot battery surface while charging

Risk of fire.

Precautions:

- ▶ Only charge battery on a non-flammable surface.
- ▶ Refer to the battery manufacturer manual for the correct handling and use of the battery.

1.6

Description

Electromagnetic Compatibility (EMC)

The term Electromagnetic Compatibility is taken to mean the capability of the product to function smoothly in an environment where electromagnetic radiation and electrostatic discharges are present, and without causing electromagnetic disturbances to other equipment.

 **WARNING**

Electromagnetic radiation

Electromagnetic radiation can cause disturbances in other equipment.

Precautions:

- ▶ Although the product meets the strict regulations and standards which are in force in this respect, GeoMax cannot completely exclude the possibility that other equipment may be disturbed.

 **CAUTION**

Use of the product with accessories from other manufacturers. For example, field computers, personal computers or other electronic equipment, non-standard cables or external batteries

This may cause disturbances in other equipment.

Precautions:

- ▶ Use only the equipment and accessories recommended by GeoMax.
- ▶ When combined with the product, other accessories must meet the strict requirements stipulated by the guidelines and standards.
- ▶ When using computers, two-way radios or other electronic equipment, pay attention to the information about electromagnetic compatibility provided by the manufacturer.

 **CAUTION**

Intense electromagnetic radiation. For example, near radio transmitters, transponders, two-way radios or diesel generators

Although the product meets the strict regulations and standards which are in force in this respect, GeoMax cannot completely exclude the possibility that the function of the product may be disturbed in such an electromagnetic environment.

Precautions:

- ▶ Check the plausibility of results obtained under these conditions.

 **CAUTION**

Electromagnetic radiation due to improper connection of cables

If the product is operated with connecting cables, attached at only one of their two ends, the permitted level of electromagnetic radiation may be exceeded and the correct functioning of other products may be impaired. For example, external supply cables or interface cables.

Precautions:

- ▶ While the product is in use, connecting cables, for example product to external battery or product to computer, must be connected at both ends.

Radios or digital cellular phones

 **WARNING**

Use of product with radio or digital cellular phone devices

Electromagnetic fields can cause disturbances in other equipment, installations, medical devices, for example pacemakers or hearing aids, and aircrafts. Electromagnetic fields can also affect humans and animals.

Precautions:

- ▶ Although the product meets the strict regulations and standards which are in force in this respect, GeoMax cannot completely exclude the possibility that other equipment can be disturbed or that humans or animals can be affected.
- ▶ Do not operate the product with radio or digital cellular phone devices in the vicinity of filling stations or chemical installations, or in other areas where an explosion hazard exists.
- ▶ Do not operate the product with radio or digital cellular phone devices near medical equipment.
- ▶ Do not operate the product with radio or digital cellular phone devices in aircrafts.
- ▶ Do not operate the product with radio or digital cellular phone devices for long periods with the product immediately next to your body.

2 Description of the System

2.1 System Components

Main components

Component	Description
Zenith60 Pro	A GNSS smart antenna with integrated communication devices.
Field controller	A multi-purpose device enabling the control of GeoMax instruments.
GeoMax Fusion	An office software used for the processing of raw GNSS data.
Zenith Manager Android	An Android based software, used to manage and configure the GNSS receiver.
Zenith Manager	An office software, used to manage and configure the GNSS receiver.

2.2 Container Contents

Container for Zenith60 Pro instrument and accessories part 1 of 2

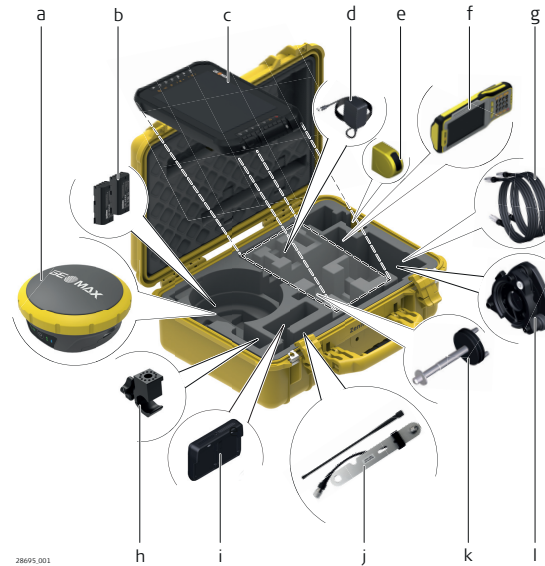

- a Zenith60 Pro instrument
- b Batteries
- c Tablet
- d Power adapter
- e Measuring tape
- f Field controller
- g Cables
- h Pole clamp
- i Charger
- j UHF antenna arm and UHF radio antenna
- k Carrier
- l Tribrach

Container content may vary.

Container for Zenith60 Pro instrument and accessories part 2 of 2

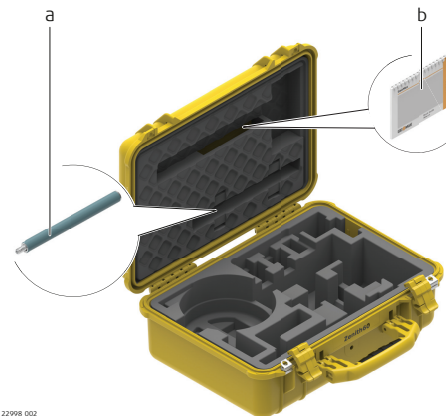

- a Pole 25 cm
- b Quick Guide

2.3 System Concept

2.3.1 Software Concept

Software upload

The software can be uploaded using Zenith60 Pro WebManager.



Refer to [4.1.6 Zenith60 ProWebManager](#).

2.3.2 Power Concept

General

Use the GeoMax batteries, chargers and accessories or accessories recommended by GeoMax to ensure the correct functionality of the instrument. The external power supply cable should not be longer than 3 meters.

Power options

Power for the Zenith60 Pro can be supplied either internally or externally.

Internal power supply: Two batteries fitting into the Zenith60 Pro.

External power supply: 9 V DC to 28 V DC external power input.

2.3.3 Data Storage Concept

Description

GNSS raw data can be recorded on the microSD card or internal memory.

Data storage device



Unplugging connecting cables or removing the microSD card during measurements can cause loss of data. Only insert or remove the microSD card or unplug connecting cables when the Zenith60 Pro is switched off.

Device	Description
microSD card	The Zenith60 Pro has a microSD card slot fitted as standard.
Internal memory	The Zenith60 Pro has an internal memory fitted as standard. Total capacity: 8 GB.

2.4 Instrument Components

Zenith60 Pro components

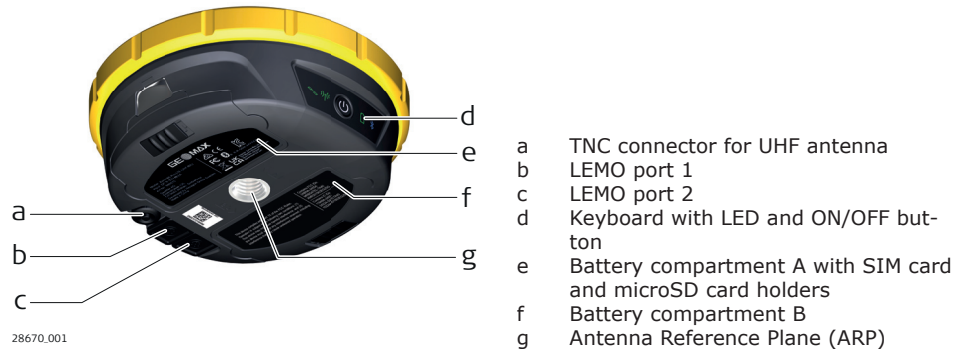

2.5 Pin Assignments

Pin assignments for port 1

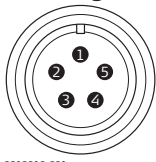

0010010.001

Pin	Signal Name	Function
1	PWR	12V power supply in
2	GND	Signal and chassis ground
3	TxD	RS232, transmit data
4	GND	Signal ground
5	RxD	RS232, receive data

Pin assignments for port 2

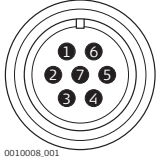

Pin	Signal Name	Function
1	NC	Not used
2	USB_D-	USB data line
3	PWR	5V power supply (USB)
4	USB_D+	USB data line
5	TxD	RS232, transmit data
6	RxD	RS232, receive data
7	GND	Signal ground

Plug types

Port1:	LEMO-1, 5 pin, LEMO EEG.0B.305.CLN
Port2:	LEMO-1, 7 pin, LEMO EEG.0B.307.CLN

2.6

The Antenna Reference Plane, ARP

Description

The Antenna Reference Plane:

- Is where the instrument heights are measured to.
 - Is where the phase centre variations refer to.
 - Varies for different instruments.
-

ARP

The ARP for the Zenith60 Pro is shown in the diagram.



23000_001



- a The Antenna Reference Plane is the underside of the thread.
-

3 User Interface

3.1 Keyboard

Description

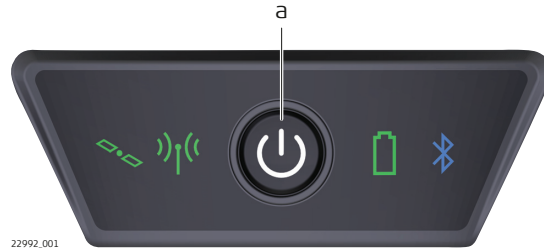

a ON/OFF button

ON/OFF button

Button	Status	Function
	If Zenith60 Pro is off	Turns on the Zenith60 Pro when held for 2 s.
		While the Zenith60 Pro is booting the Power LED is solid green while the other LED are off.
		Shows the battery status when the ON/OFF button is pressed and held for less than 2 s.
		Starts the recovery process when held > 8 s. Refer to 4.6 Recovery Process for more details.
	If Zenith60 Pro is on	Turns off the Zenith60 Pro when held for 2 s.

3.2 LED Indicators

LED indicators

The Zenith60 Pro has Light Emitting Diode indicators. They indicate the basic instrument status.

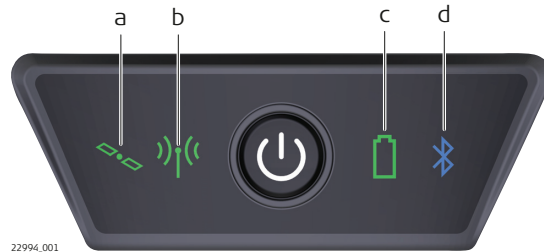

a Position LED
b RTK LED
c Power LED
d Bluetooth LED

Description of the LED

LED	Status	Description
Position LED	Off	No satellites are tracked.
	Flashing yellow	Fewer than four satellites are tracked. A position is not yet available.
	Yellow	A navigated position is available.
	Flashing green	A code-only position is available.
	Green	A fixed RTK position is available.
RTK LED	Off	The device is not configured to receive or send out the RTK data or device is in static mode.
	Green	Zenith60 Pro is in rover mode. No RTK data is being received at the interface of the communication device.

LED	Status	Description
	Flashing green	Zenith60 Pro is in rover mode. RTK data is being received at the interface of the communication device.
	Yellow	Zenith60 Pro is in RTK base mode. No RTK data is being passed to the interface of the communication device.
	Flashing yellow	Zenith60 Pro is in RTK base mode. RTK data is being passed to the interface of the communication device.
Power LED	Off	The batteries are not connected, are both flat or the Zenith60 Pro is switched off.
	Green	Total power is 20% - 100%.
	Red	Total power is 5% - 20%. The remaining time for which enough power is available depends on the type of survey, the temperature and the age of the batteries.
	Fast flashing red	Total power is low (< 5%).
Bluetooth LED	Off	Bluetooth is not connected.
	Blue	Bluetooth is connected.
All LED	Flashing sequentially	The factory reset is initiated.
Bluetooth LED Power LED RTK LED Position LED	Flashing blue Solid green Flashing green Flashing green	The recovery process is initiated.

4

Operation

4.1

Equipment Setup

4.1.1

Setting up as a Real-Time Base

Equipment setup - Zenith60 Pro

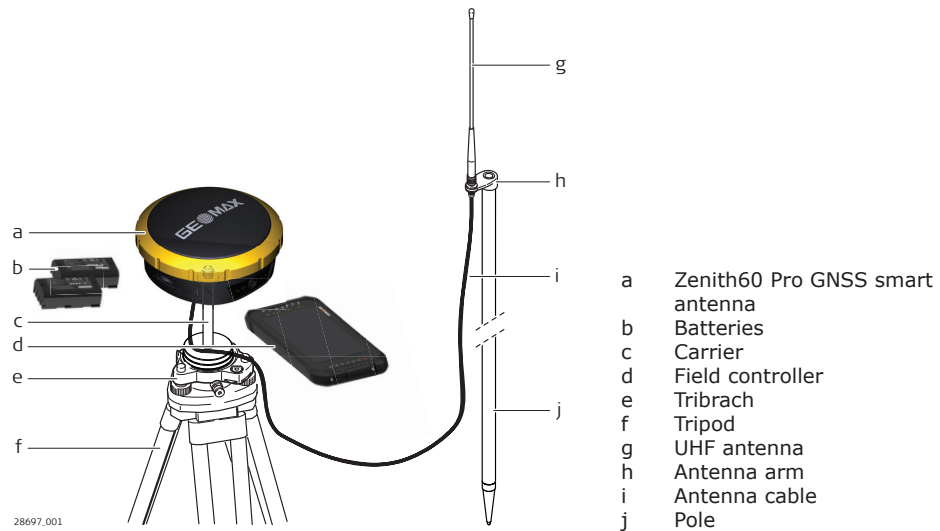

Equipment setup step-by-step

1. Set up the tripod.
2. Mount the tribrach on the tripod.
3. Ensure that the tribrach is over the marker.
4. Mount and level the carrier on the tribrach.
5. Insert the batteries into the instrument.
6. Connect the UHF antenna to the instrument using the antenna arm and the antenna cable.
7. Press the ON/OFF button on the instrument for 2 s to switch on the instrument.
8. Screw the instrument onto the carrier.
9. Check that the tribrach and carrier are still level.
10. Connect the field controller to the GNSS smart antenna through Bluetooth or WLAN.
11. Measure the instrument height using the measuring tape. Refer to [2.6 The Antenna Reference Plane, ARP](#) for information on the instrument height.

4.1.2

Setting up as a Post-Processing Base

Use

The following equipment setup is used for static operations over markers.

Equipment setup - Zenith60 Pro

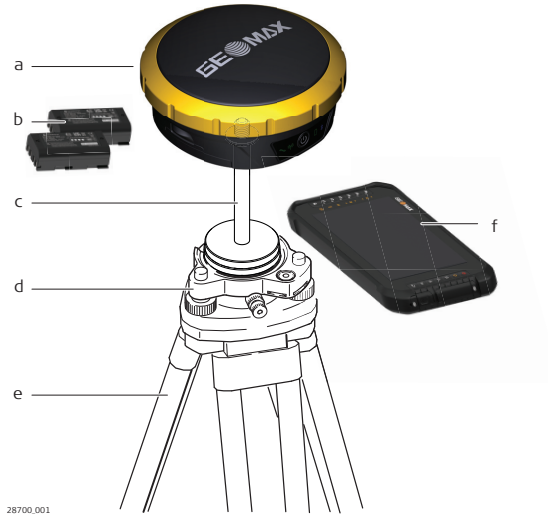

- a Zenith60 Pro GNSS smart antenna
- b Batteries
- c Carrier
- d Tribrach
- e Tripod
- f Field controller

Equipment setup step-by-step

1. Set up the tripod.
2. Mount the tribrach on the tripod.
3. Ensure that the tribrach is over the marker.
4. Mount and level the carrier on the tribrach.
5. Insert the batteries into the instrument.
6. Press the ON/OFF button on the instrument for 2 s to switch on the instrument.
7. Screw the instrument onto the carrier.
8. Check that the tribrach and carrier are still level.
9. Connect the field controller to the GNSS smart antenna through Bluetooth or WLAN.
10. Measure the instrument height using the measuring tape. Refer to [2.6 The Antenna Reference Plane, ARP](#) for information on the instrument height.

4.1.3

Setting Up as a Real-Time Rover

Use

The following equipment setup is used for real-time rover.

Equipment setup - Zenith60 Pro

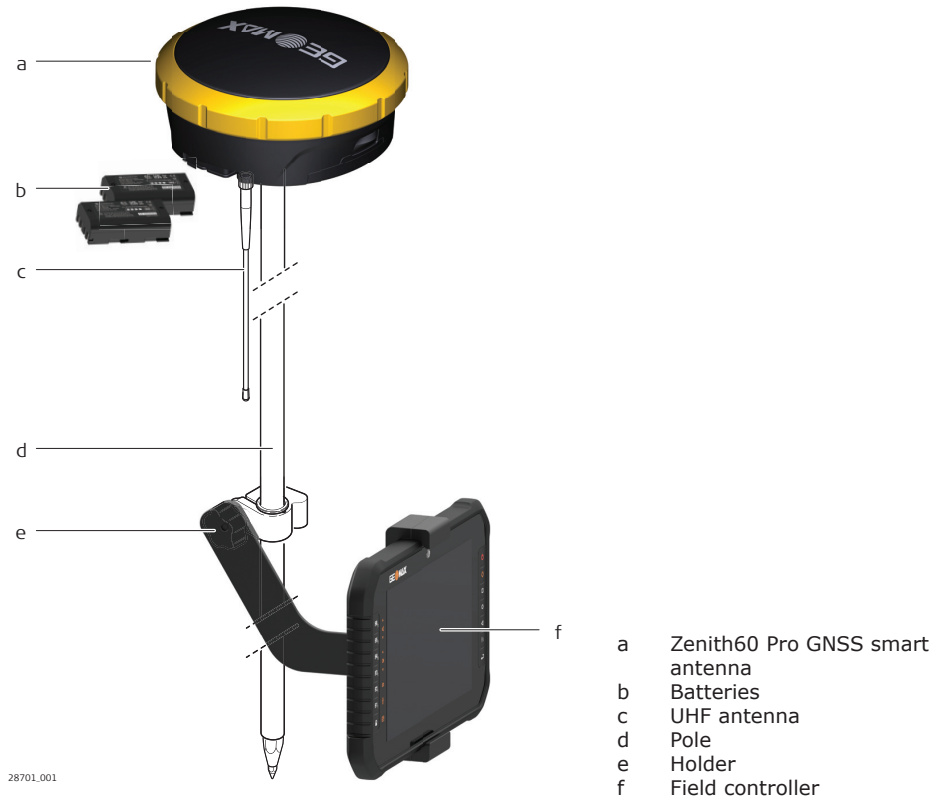

Equipment setup step-by-step

1. Attach the field controller to the pole.
Clip the field controller into the holder and lock it by tightening the screw on the holder.
2. Turn on the field controller.
3. Insert the batteries into the GNSS smart antenna.
4. Connect the UHF antenna to the GNSS smart antenna. This connection is only required when using the internal radio.
5. Press ON/OFF button on the GNSS smart antenna for 2 s to switch on the GNSS smart antenna.
6. Screw the GNSS smart antenna on to the top of the pole.
7. Connect the field controller to the GNSS smart antenna through Bluetooth or WLAN.

4.1.4

Pole holder assembly

Pole holder components



Fixing the field controller to the holder step-by-step

1. Insert the pole into the clamp hole.
2. Tighten the clamp with the tightening screw.
3. To attach the holder to the clamp insert the pin into the catch of the clamp while pushing down the locking pin.
4. Place the field controller in the holder.
5. Tighten the screw of the holder to fix the field controller to the holder.

4.1.5

Connecting to a Personal Computer

Description

The instrument is connected to a Personal Computer via serial/USB cable.

Install software

1. Start the PC.
2. Download the cable driver from the GeoMax website.
3. Install the cable driver on a PC using a Windows operating system.

Connect the Zenith60 Pro to a computer

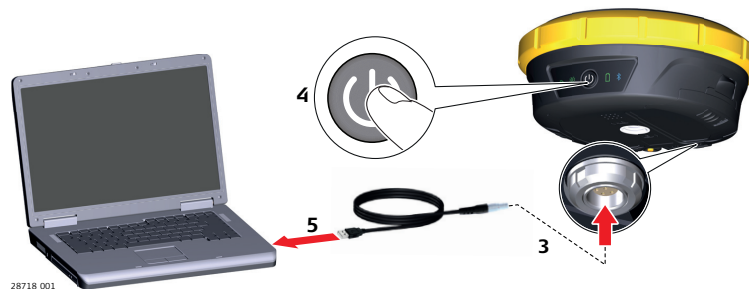

1. Start the computer.
2. Plug the included cable into the port of the Zenith60 Pro.
3. Turn on the Zenith60 Pro.
4. Plug the cable into the USB port of the computer. If Windows Hardware Wizard starts up, select **CLOSE**.

4.1.6

Zenith60 Pro WebManager

Description

The Zenith60 Pro WebManager software can be used to set up, configure and operate the instrument, download data from the instrument and microSD card, enter licence keys and upload firmware.

Start Zenith60 Pro WebManager

1. Turn on the Zenith60 Pro instrument.
2. Make sure that the WLAN on your PC/mobile device is turned on. Search for available connections.
3. When the instrument is found, select it to connect with your PC/mobile device.
4. As soon as the connection is established, start the web browser. Enter the IP `http://192.168.10.1` into the address bar. A login-window will pop up.
5. Enter the user name and password. The default values are:
 - User name: admin
 - Password: password
6. After a successful login, the **Position/Link Information** screen of the Zenith60 Pro WebManager appears and the instrument can be accessed.

Menu functions

Function	Description
Hardware Information	To view information about the GNSS instrument such as firmware versions and hardware models.
Position/Link Information	To view the current status of the GNSS instrument.
Satellite Information	To view a list or skyplot of all currently used and tracked satellites.
Satellite Settings	To enable or disable satellite systems or individual satellites.
Sensor Settings	To configure the sensor settings and working mode including NMEA streaming.
Format Sensor	To format the memory and microSD card, reset to factory settings, perform a self-test on the instrument or restart the instrument.
Firmware File	To upload instrument, ME, UHF and GSM firmware. Refer to Sensor firmware .
Antenna File	To upload base antenna calibration values to the instrument.
Data Download	To download data files from the internal memory of the instrument or the inserted microSD card in DAT or RINEX formats. Refer to Download data .

Download data

In the **Download Data** tab, select the file that you want to download. Both .DAT and Rinex files can be directly downloaded. The raw data is transferred from the instrument to the PC where it can be processed using the GeoMax X-PAD Fusion office software.

Radio settings



To meet country radio licence requirements, the internal UHF radio must be set before use to legally allowed local frequencies as defined by local or governmental authorities. Use of forbidden frequencies may lead to prosecution and penalties.

In the **Sensor Settings** tab, the internal radio can be configured with a channel, protocol type, and channel spacing. Various required frequencies can be entered into the channel table and assigned to a specific channel number.

Sensor firmware

The latest version of the instrument firmware is available from the GeoMax website.

4.2

Batteries

4.2.1

Operating Principles

Charging / first-time use

- The battery must be charged prior to using it for the first time because it is delivered with an energy content as low as possible.
- The permissible temperature range for charging is between $-10\text{ }^{\circ}\text{C}$ to $+55\text{ }^{\circ}\text{C}$ / $+14\text{ }^{\circ}\text{F}$ to $+131\text{ }^{\circ}\text{F}$. For optimal charging we recommend charging the batteries at a low ambient temperature of $+10\text{ }^{\circ}\text{C}$ to $+45\text{ }^{\circ}\text{C}$ / $+50\text{ }^{\circ}\text{F}$ to $113\text{ }^{\circ}\text{F}$ if possible.
- It is normal for the battery to become warm during charging. Using the chargers recommended by GeoMax, it is not possible to charge the battery if the temperature is too high.
- For new batteries or batteries that have been stored for a long time ($>$ three months), it is effectual to make only one charge/discharge cycle.
- For Li-Ion batteries, a single discharging and charging cycle is sufficient. We recommend carrying out the process when the battery capacity indicated on the charger or on a GeoMax product deviates significantly from the actual battery capacity available.

Operation/Discharging

- The batteries can be operated from $-30\text{ }^{\circ}\text{C}$ to $+65\text{ }^{\circ}\text{C}$ / $-22\text{ }^{\circ}\text{F}$ to $+149\text{ }^{\circ}\text{F}$.
- Low operating temperatures reduce the capacity that can be drawn.
- High operating temperatures reduce the service life of the battery.

4.2.2

Insert and Remove the Battery

Change battery step-by-step



28671_001



The batteries are inserted at the bottom of the Zenith60 Pro.

1. To remove a battery:
 - a) Push the slide fastener of the battery compartment in the direction of the open-lock symbol.
 - b) Press the button to open the battery compartment.
2. Push the battery sideward to release the battery from its fixed position.
3. Remove the battery.
4. To insert the battery, push the slide fastener of the battery compartment in the direction of the open-lock symbol.
5. Open the battery compartment.
6. Insert the battery into the battery compartment aligning the contacts.
7. Slide the battery in the compartment so that it locks into position.
8. Close the battery compartment and push the slide fastener in the direction of the closed-lock symbol.

4.3

Inserting a microSD/SIM Card



- Keep the card dry.
- Use it only within the specified temperature range.
- Do not bend the card.
- Protect the card from direct impacts.



Failure to follow these instructions could result in data loss and/or permanent damage to the card.

Inserting a microSD/SIM card, step-by-step

Inserting a microSD card



28672.001



Removing the microSD card while the instrument is turned on can cause loss of data. Only insert or remove the microSD card or unplug connecting cables when the instrument is switched off.



The microSD card is inserted into a slot inside battery compartment A.

1. Open battery compartment A.
2. Remove the battery.
3. Remove the cover marked with SD.
4. Insert the microSD card with the logo facing upwards and lock it into position.

Inserting a SIM card



28673.001



Inserting/removing the SIM card while the Zenith60 Pro is turned on can result in permanent damage to the card. Only insert/remove the SIM card when the Zenith60 Pro is switched off.



The SIM card is inserted into a slot inside battery compartment A.

1. Open battery compartment A.
2. Remove the battery.
3. Remove the cover marked with SIM.
4. Insert the SIM card with the connectors facing downwards and lock it into position.

4.4

Working with the Tilt Compensation

This option is supported only in field software (for example X-PAD).

Description

Points can be measured with a tilted pole while holding the pole tip over the point. That eliminates the need to check whether the circular bubble on the pole is levelled.

Measurements performed with a tilted pole are reliable and accurate. The Inertial Measurement Unit (IMU) measures and defines the amount and the orientation of the tilt.

Measurements are immune to magnetic interferences due to the IMU implemented in the sensor.

To be able to perform measurements with a tilted pole, it is required to have a fixed RTK solution.

When measuring points with a tilted pole, initialise the IMU. The IMU or tilt compensation can be initialised by moving the sensor around. Initialisation status is indicated in X-PAD field software. Move the sensor to maintain the initialisation, for example moving to the next point to be measured.

Points can also be staked out using the tilted pole.

Advantages:

- No need to level the pole
- Faster surveying procedures
- Faster staking out of points

Diagram

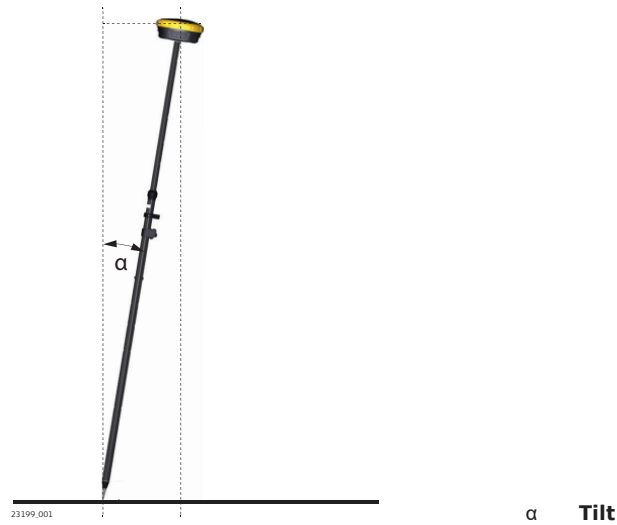

Tilt compensation, step-by-step

This step-by-step procedure describes the tilt compensation implemented into the X-PAD field software,



Zenith60 Pro must be configured to receive RTK correction data and the sensor needs to have reached a fixed solution.

1. Inside the selected job, go to the **Survey** tab and select **Survey points**.
2. To enable tilt compensated measurements go to **Tools** and select **Survey setup**.
3. In the **GNSS** tab, under **Sensor mode** select the **Tilted pole (GNSS receiver)** option and press **Accept**.
4. The tilt initialisation icon appears in the bottom right corner of the screen, showing that tilt functionality is activated.

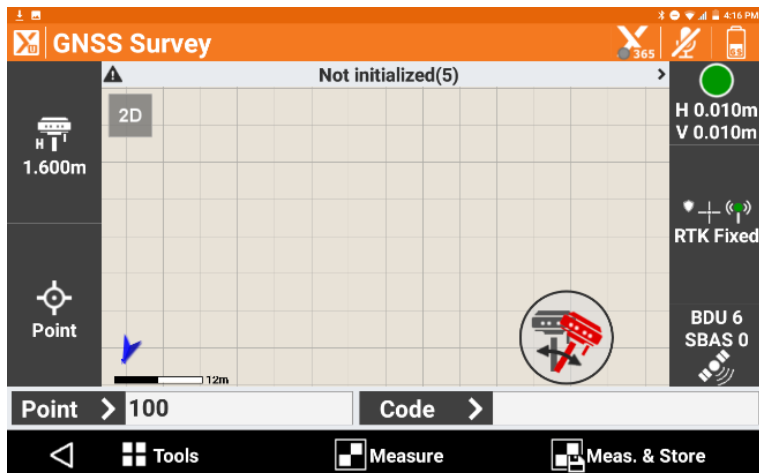



The tilt initialisation icon shown on the right appears when the tilt compensation is activated, but not yet initialised to have high accuracy. Measurements cannot be taken yet.



If IMU does not work, the icon shown on the right side is displayed. This behaviour occurs in rare cases.



- To initialise tilt compensation, move the antenna around by walking or shake the antenna back and forth.



During the initialisation process, the icon shown on the right may appear. This icon indicates that tilt is being initialised.



Once the tilt compensation is initialised and good GNSS accuracy has been met, the icon shown on the right appears. This icon shows the current amount of tilt and means measurements can now be performed.



- There is a possibility to perform a user calibration. To do so, press the tilt icon and select **Calibrate**. This calibration is optional and needs to be performed only if the setup has been changed. For example, a different pole is used.
- Press **Measure** or **Meas. & Store** to measure points.
- Use **3D view** for a 3D overview of the current position in GNSS survey.

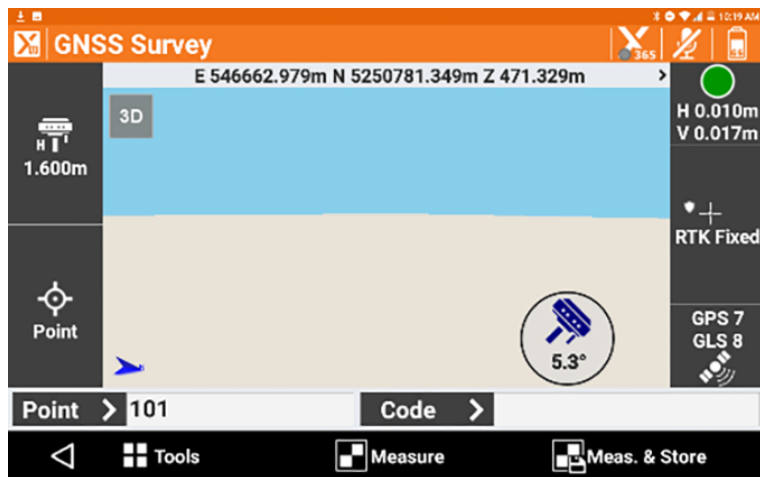

Application example:

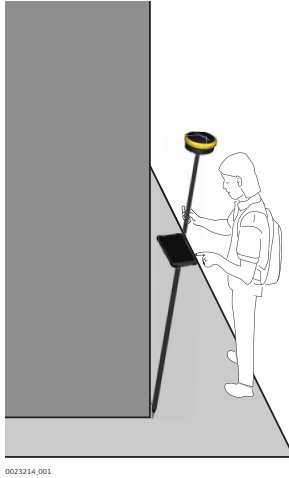

9. **Stakeout**

Inside the selected job go to the **Stakeout** tab and select one option.

10. Perform a stake out as instructed by the arrow and the values on the left side of the screen.

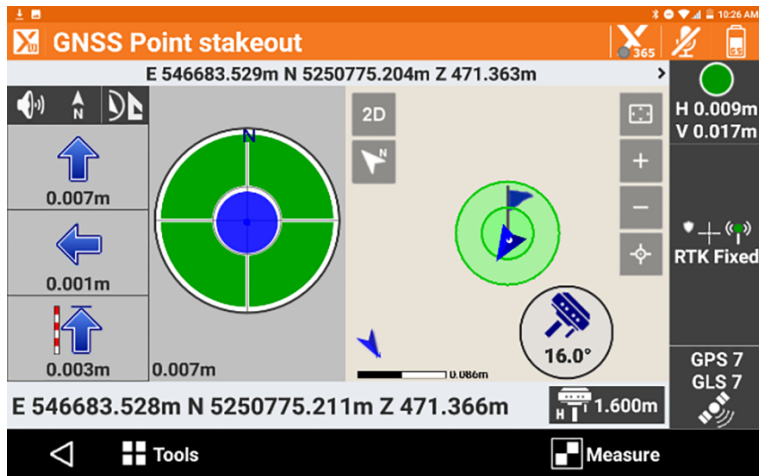

4.5

Guidelines for Correct Results with GNSS Surveys

Undisturbed satellite signal reception

Successful GNSS surveys require undisturbed satellite signal reception, especially at the instrument which serves as a base. Set up the instrument in locations which are free of obstructions such as trees, buildings or mountains.

Steady instrument for static surveys

For static surveys, the instrument must be kept perfectly steady throughout the entire occupation of a point. Place the instrument on a tripod or pillar.

Centred and levelled instrument

Centre and level the instrument precisely over the marker.

Tilt measurement

The Zenith60 Pro has an integrated Inertial Measurement Unit (IMU) that is used in combination with GNSS measurements. It has the following advantages:

- It allows tilt compensated measurements that are immune to the magnetic interferences.
- There is no need to calibrate the sensor.
- The pole can be tilted up to 60°. To ensure high accuracy measurements, it is recommended that the pole is tilted no more than 30°.
- Precondition for performing tilt compensated measurements is the initialising of the IMU. To initialise the IMU, move the Zenith60 Pro around by taking a few steps or shaking the antenna back and forth.

4.6

Recovery Process

Recovery process, step-by-step

In case of an incomplete booting process, the battery LED is permanently solid green. The integrated recovery process could help.



With this recovery process, also the firmware is set back to a pre-defined beta-version. Upgrade the firmware afterwards again to the latest instrument firmware version. Otherwise the antenna cannot be used!

Action	Result
1. Press and hold the Power button.	<i>Battery LED flashes once and is solid green afterwards.</i>
2. Release Power button after about 8 s.  Instrument is ready to start the recovery.	<i>All LEDs flashing fast.</i>
3. Press and hold Power button until LED flashing stops. Approximately 3 s. Release Power button.	<i>Battery LED is solid green.</i>
4. After about 15 s, the recovery process starts automatically.	<i>All LEDs flashing.</i>
5. After about 2 min, the instrument switches off automatically.	<i>All LED off.</i>
6. After about 15 s, the instrument boots up again automatically.	<i>Battery LED is solid green.</i>
7. After about 30 s, the booting process finishes. The instrument is ready again.	<i>Battery LED and RTK LED are solid green.</i>
8. Use the WebManager to perform a factory reset.	The factory reset ensures reading out current values.
9. Check instrument firmware. Upgrade to the latest one.	

5 Care and Transport

5.1 Transport

Transport in the field

When transporting the equipment in the field, always make sure that you

- either carry the product in its original container,
 - or carry the tripod with its legs splayed across your shoulder, keeping the attached product upright.
-

Transport in a road vehicle

Never carry the product loose in a road vehicle, as it can be affected by shock and vibration. Always carry the product in its container and secure it.

Shipping

When transporting the product by rail, air or sea, always use the complete original GeoMax packaging, transport container and cardboard box, or its equivalent, to protect against shock and vibration.

Shipping, transport of batteries

When transporting or shipping batteries, the person responsible for the product must ensure that the applicable national and international rules and regulations are observed. Before transportation or shipping, contact your local passenger or freight transport company.

5.2 Storage

Product

Respect the temperature limits when storing the equipment, particularly in summer if the equipment is inside a vehicle. Refer to [6 Technical Data](#) for information about temperature limits.

Battery care

- A rechargeable Li-Ion battery powers the instrument. The full performance of a new battery is achieved only after two or three complete charge and discharge cycles
 - The battery can be charged and discharged hundreds of times. It eventually wears out
 - Do not leave a fully charged battery connected to a charger, as overcharging may shorten its life
 - If left unused, a fully charged battery loses its charge over time
-

Li-Ion batteries

- Refer to [6 Technical Data](#) for information about storage temperature range
 - Remove batteries from the product and the charger before storing
 - After storage recharge batteries before using
 - Protect batteries from damp and wetness. Wet or damp batteries must be dried before storing or use
 - A storage temperature range of 0 °C to +30 °C / +32 °F to +86 °F in a dry environment is recommended to minimize self-discharging of the battery
 - At the recommended storage temperature range, batteries containing a 40% to 50% charge can be stored for up to one year. After this storage period the batteries must be recharged
-

5.3 Cleaning and Drying

Product and accessories

- Use only a clean, soft, lint-free cloth for cleaning. If necessary, moisten the cloth with water or pure alcohol. Do not use other liquids; these may attack the polymer components.
-

Damp products

Dry the product, the transport container, the foam inserts and the accessories at a temperature not greater than 40 °C/104 °F and clean them. Remove the battery cover and dry the battery compartment. Do not repack until everything is dry. Always close the transport container when using in the field.

Cables and plugs

Keep plugs clean and dry. Blow away any dirt lodged in the plugs of the connecting cables.

Connectors with dust caps

Wet connectors must be dry before attaching the dust cap.

6 Technical Data

6.1 Technical Data

6.1.1 Tracking Characteristics

Tracking GNSS smart antenna: Multi-frequency with 800+ channels.

Satellite system	Signals
GPS tracking	L1 C/A, L1P, L1C, L2C, L2P, L5
GLONASS tracking	L1 C/A, L1P, L2 C/A, L2P, L3
BeiDou tracking	B1I, B1C, B2I, B2a, B2b, B3I, ACEBOC
Galileo tracking	E1, E5a, E5b, E6, AltBOC
QZSS	L1 C/A, L1C, L2C, L5, L6
NavIC	L5
SBAS	L1, L5

Time for initialisation: Typically 4 s

Positioning rate: 20 Hz

6.1.2 Accuracy

RTK

Mode	Value
Horizontal	8 mm + 1 ppm
Vertical	15 mm + 1 ppm

Network RTK

Mode	Value
Horizontal	8 mm + 0.5 ppm
Vertical	15 mm + 0.5 ppm

Static

Mode	Value
Horizontal	3 mm + 0.5 ppm
Vertical	5 mm + 0.5 ppm

Static long

Mode	Value
Horizontal	3 mm + 0.1 ppm
Vertical	3.5 mm + 0.4 ppm

Tilt compensated real-time kinematic

Additional Hz uncertainty: 2 cm up to 30° tilt



Accuracy is dependent upon various factors including the number of satellites tracked, constellation geometry, observation time, ephemeris accuracy, ionospheric disturbance, multipath and resolved ambiguities.

The accuracies, given as **root mean square**, are based on measurements processed using GeoMax Fusion and on real-time measurements.

6.1.3 GNSS antenna specifications

GNSS antenna specifications

Description	Value
Phase centre offset	±2 mm
LNA gain	40 ±2 dBi

6.1.4 Internal devices

Internal devices

Module	Specification
LTE/GSM/UMTS	QUECTEL EG25-G 4G LTE FDD: B1/B2/B3/B4/B5/B7/B8/B12/B13/B18/B19/B20/B25/B26/B28 4G LTE TDD: B38/B39/B40/B41 3G UMTS: B1/B2/B4/B5/B6/B8/B19 2G GSM: B2/B3/B5/B8 Nano SIM card
UHF radio module	Satel TR4+ Transmission power 0.5 and 1.0 W Frequency range 403 to 473 MHz
Bluetooth	GEBW2455A, 2.1 +EDR, V5.0
WLAN	802.11 b/g/n Hotspot/client mode

6.1.5 Technical Data

Dimensions



Description	Value
Height	75 mm
Diameter	166.8 mm

Weight

Weight	Value
Zenith60 Pro without batteries	1.14 kg
Zenith60 Pro with 2 batteries	1.36 kg

Recording

GNSS raw data can be recorded on a microSD card or internal memory. 1 GB capacity is typically sufficient for about 7000 h dual frequency logging at a 15 s rate at average constellation.

Memory	Total capacity
Internal memory	8 GB
microSD card	16 GB

Power

Power	Value
Battery	2 Li-Ion batteries, rechargeable and replaceable 7.2 V/3400 mAh
Voltage	9 V DC to 28 V DC external power input 5-pins Lemo

Operating times

Description	Value
Working time	Up to 12.5 hours, 2 batteries hot swap
Charge time	Typically 4 hours
Rover (Radio, Satel TR4+, receive)	11 hours
Rover (Digital cellular phone, QUECTEL EG25-G)	11 hours
Base	12.5 hours



Operating times may vary depending on the temperature and battery age.

6.2

Environmental specifications

Environmental specifications

Temperature

Type	Operating temperature [°C]	Storage temperature [°C]
Zenith60 Pro	-40 to +65	-40 to +80

Protection against water, dust and sand

Type	IP class
Zenith60 Pro	IP68 (IEC 60529) Withstands powerful jets and temporarily immersion under water. Fully dust tight.

Pollution degree

Type	Pollution degree
Zenith60 Pro	4 Electrical equipment for indoor and outdoor use. Electrical equipment for usage in industrial environment.

Humidity

Type	Protection
Zenith60 Pro	MIL-STD-810H, Method 507.6 Max 95% non-condensing.

Altitude

Type	Range
Zenith60 Pro	Unrestricted

Shock resistance

Type	Value
Zenith60 Pro	Designed to endure to a 2 m pole drop and 1.2 m free drop on hard surface with no damage.

Vibration

Type	Value
Zenith60 Pro	ISO 9022-36-05-2 10-55 Hz, ±0.15 mm, 5 cycles

6.3

Conformity to National Regulations

Labelling Zenith60 Pro

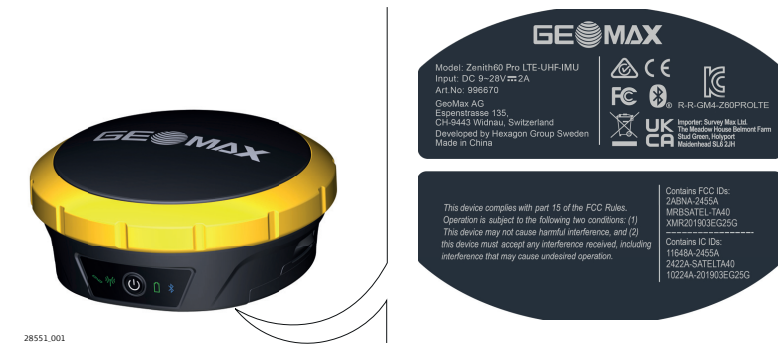

Labelling internal battery

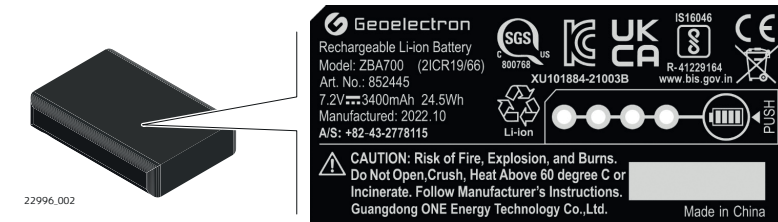

Antenna

Type	Antenna	Gain [dBi]
GNSS	Internal GNSS antenna element (receive only)	5.5 max.
Bluetooth	Internal ceramic antenna	1.0 max.
UHF	Detachable $\lambda/4$ antenna	4 max.
GSM/ UMTS/LTE	Internal patch antenna	0.5 max. @ 800/850/900 MHz 0.5 max. @ 1800/1900/2100 MHz
WLAN	Internal ceramic antenna	1.0 max.

Frequency band

Type	Zenith60 Pro Frequency band (MHz)
GNSS smart antenna	GPS L1: 1575.42 GPS L2: 1227.60 GPS L5: 1176.45 GLONASS L1: 1602.5625 - 1611.5 GLONASS L2: 1246.4375 - 1254.3 GLONASS L3: 1202.025 Galileo E1: 1575.42 Galileo E5a: 1176.45 Galileo E5b: 1207.14 Galileo E6: 1278.75 Galileo AltBOC: 1191.795 QZSS L5: 1176.45 NavIC L5: 1176.45 BeiDou B1: 1561.098 BeiDou B2: 1207.140 BeiDou B3: 1268.52
Bluetooth	2402 - 2480
Radio	403 - 473

Output power

Type	Output Power [mW]
GNSS	Receive only
Bluetooth	5
Radio	1000
2G GSM	1000, 2000
3G UMTS	300
4G LTE	300
WLAN	100 max. (e.i.r.p.)

EU



Hereby, GeoMax AG declares that the radio equipment type Zenith60 Pro is in compliance with Directive 2014/53/EU and other applicable European Directives.

The full text of the EU declaration of conformity is available at the following Internet address: <https://geomax-positioning.com/partner-area>.

UKCA

Hereby, GeoMax AG declares that the radio equipment type Zenith60 Pro is following the provisions of the applicable relevant statutory requirement S.I. 2012 No. 3032 The Restriction of the Use of Certain Hazardous Substances in Electrical and Electronic Equipment Regulations 2012, S.I. 2017 No. 1206 Radio Equipment Regulations 2017.

USA

Contains FCC ID: 2ABNA-2455A, MRBSATEL-TA40, XMR201903EG25G
FCC Part 15, 22, 24 and 27

This equipment has been tested and found to comply with the limits for a Class B digital device, pursuant to part 15 of the FCC Rules.

These limits are designed to provide reasonable protection against harmful interference in a residential installation.

This equipment generates, uses, and can radiate radio frequency energy and, if not installed and used in accordance with the instructions, it may cause harmful interference to radio communications.

However, there is no guarantee that interference does not occur in a particular installation. If this equipment does cause harmful interference to radio or television reception, which can be determined by turning the equipment off and on, the user is encouraged to try to correct the interference by one or more of the following measures:

- Reorient or relocate the receiving antenna.
- Increase the separation between the equipment and the receiver.
- Connect the equipment into an outlet on a circuit different from that to which the receiver is connected.
- Consult the dealer or an experienced radio/TV technician for help.

Changes or modifications not expressly approved by GeoMax for compliance could void the user's authority to operate the equipment.

Canada

CAN ICES-003 B/NMB-003 B
Contains IC: 11648A-2455A, 2422A-SATELTA40, 10224A-201903EG25G

Canada Compliance Statement

This device contains licence-exempt transmitter(s)/receiver(s) that comply with Innovation, Science and Economic Development Canada's licence-exempt RSS(s). Operation is subject to the following two conditions:

1. This device may not cause interference
2. This device must accept any interference, including interference that may cause undesired operation of the device

Canada Déclaration de Conformité

L'émetteur/récepteur exempt de licence contenu dans le présent appareil est conforme aux CNR d'Innovation, Sciences et Développement économique Canada applicables aux appareils radio exempts de licence. L'exploitation est autorisée aux deux conditions suivantes:

1. L'appareil ne doit pas produire de brouillage
2. L'appareil doit accepter tout brouillage radioélectrique subi, même si le brouillage est susceptible d'en compromettre le fonctionnement

Radio Frequency (RF) Exposure Compliance Statement

The radiated RF output power of the instrument is below the Health Canada's Safety Code 6 exclusion limit for portable devices (radiated element separation distance between the radiating element and user and/or bystander is below 20 cm).

Others

The conformity for countries with other national regulations has to be approved prior to use and operation.

6.4

Dangerous Goods Regulations

Dangerous Goods Regulations

The products of GeoMax are powered by Lithium batteries.

Lithium batteries can be dangerous under certain conditions and can pose a safety hazard. In certain conditions, Lithium batteries can overheat and ignite.



When carrying or shipping your GeoMax product with Lithium batteries onboard a commercial aircraft, you must do so in accordance with the **IATA Dangerous Goods Regulations**.



GeoMax has developed **Guidelines** on "How to carry GeoMax products" and "How to ship GeoMax products" with Lithium batteries. Before any transportation of a GeoMax product, we ask you to consult these guidelines on our web page (<http://www.geomax-positioning.com/dgr>) to ensure that you are in accordance with the IATA Dangerous Goods Regulations and that the GeoMax products can be transported correctly.



Damaged or defective batteries are prohibited from being carried or transported onboard any aircraft. Therefore, ensure that the condition of any battery is safe for transportation.

1000795-1.0.0en

Original text (1000795-1.0.0en)

© 2024 GeoMax AG is part of Hexagon AB.
All rights reserved.

GeoMax AG

Espenstrasse 135

9443 Widnau

Switzerland

[geomax-positioning.com](https://www.geomax-positioning.com)

