

---

## SurvPC

---

## User Manual

---





# Contents

1	End-User License Agreement .....	6
2	Installation .....	10
2.1	Using the Manual .....	10
2.2	Installing SurvPC .....	11
2.3	Authorizing SurvPC .....	14
2.4	Hardware Notes .....	16
2.5	Color Screens .....	16
2.6	Battery Status .....	16
2.7	Carlson Technical Support .....	16
2.8	Customer Service, Technical Support, Repair: .....	16
3	User Interface .....	17
3.1	Graphic Mode .....	18
3.2	View Options .....	21
3.3	Quick Calculator .....	23
3.4	Hot Keys / Hot list / Helmet Menu .....	24
3.5	Carlson Cloud.....	30
3.6	Instrument Selection .....	32
3.7	Input Box Controls.....	33
3.8	Keyboard Operation .....	36
3.9	Abbreviations .....	38
4	File .....	39
4.1	Job .....	40
4.2	Job Settings (New Job).....	42
4.3	Job Settings (System).....	44
4.4	Job Settings (Format).....	46
4.5	Job Settings (Options).....	48
4.6	Job Settings (Stake) .....	60
4.7	Points.....	70
4.8	Raw Data .....	73
4.9	Feature Code List.....	82
4.10	Data Transfer .....	114
4.11	Import / Export.....	116
4.12	Delete Job .....	122



4.13	About Carlson SurvPC.....	123
4.14	Exit.....	123
<b>5</b>	<b>Equip.....</b>	<b>124</b>
5.1	Total Station .....	125
5.2	Total Station Prism Search by GPS .....	132
5.3	GPS Setup .....	135
5.4	GPS Base.....	144
5.5	GPS Rover .....	153
5.6	GPS Raw Only .....	166
5.7	Configure (General) .....	176
5.8	Configure (View).....	187
5.9	Configure (Sets) .....	191
5.10	Configure (IMU).....	193
5.11	Hybrid+ .....	199
5.12	Localization.....	220
5.13	Monitor / SkyPlot (GPS).....	236
5.14	Mission Planning .....	239
5.15	Check Level (Total Station) .....	243
5.16	Tolerances .....	244
5.17	Peripherals.....	246
5.18	GPS Utilities .....	253
<b>6</b>	<b>Survey .....</b>	<b>256</b>
6.1	Orientation (Instrument Setup).....	257
6.2	Orientation (Backsight).....	260
6.3	Orientation (Remote Benchmark) .....	263
6.4	Orientation (Advanced Occupation).....	264
6.5	Orientation (Robotics) .....	277
6.6	Store Points (TS) .....	279
6.7	Store Points (TS Offsets).....	290
6.8	Store Points (GPS).....	294
6.9	Store Points (GPS Offsets) .....	303
6.10	Stake Points .....	308
6.11	Stake Line / Arc.....	324
6.12	Stake Offset .....	342
6.13	Elevation Difference .....	347
6.14	Grid / Face .....	355



6.15	Resection .....	357
6.16	Set Collection.....	362
6.17	Leveling.....	368
6.18	Auto by Interval .....	376
6.19	Remote Elevation .....	381
6.20	Log Raw GPS .....	383
<b>7</b>	<b>Cogo.....</b>	<b>386</b>
7.1	Keyboard Input.....	387
7.2	Inverse .....	389
7.3	Areas.....	391
7.4	Intersections.....	393
7.5	Point Projection.....	398
7.6	Station Store.....	403
7.7	Transformation.....	406
7.8	Calculator .....	410
7.9	Manual Traverse.....	416
7.10	Point Average .....	420
<b>8</b>	<b>Road.....</b>	<b>430</b>
8.1	Centerline Editor .....	431
8.2	Draw Centerline.....	435
8.3	Profile Editor.....	436
8.4	Draw Profile.....	439
8.5	Template Editor .....	440
8.6	Draw Template .....	446
8.7	Utilities .....	447
8.8	Store Sections.....	466
8.9	Stake Slope .....	477
8.10	Stake Road.....	499
<b>9</b>	<b>Map.....</b>	<b>563</b>
9.1	Basics .....	564
9.2	File .....	571
9.3	View.....	592
9.4	Draw .....	600
9.5	Cogo.....	631
9.6	Tools .....	645



---

10	Tutorials .....	665
10.1	Tutorial 1: Calculating a Traverse (By Hand) with SurvPC .....	665
10.2	Tutorial 2: Performing Math Functions in Carlson SurvPC Input Boxes .....	667
10.3	Tutorial 3: Defining Field Codes, Line/Layer Properties & GIS Prompting...	668
10.4	Tutorial 4: Standard Procedures for Conducting GNSS Localizations .....	680
10.5	Tutorial 5: Performing a Compass Rule Adjustment .....	689
11	Troubleshooting.....	694
11.1	GPS Heights .....	694
11.2	Miscellaneous Instrument Configuration .....	694
11.3	Supported File Formats .....	695
12	Raw Data .....	696
12.1	File Format.....	696
13	Index.....	702



# 1 End-User License Agreement

Copyright © 1992-2018 Carlson Software

All Rights Reserved

**CAUTION! READ THIS NOTICE CAREFULLY BEFORE USING SOFTWARE.**

Use of this software indicates acceptance of the terms and conditions of the Software License Agreement.

## SurvPC End-User License Agreement

**IMPORTANT-READ CAREFULLY:** This Carlson Software End-User License Agreement ("EULA") is a legal agreement between you (either an individual or a single entity) and Carlson Software, Inc for the Carlson SOFTWARE accompanying this EULA, which includes computer software and may include associated media, printed materials, and "online" or electronic documentation ("SOFTWARE PRODUCT" or "SOFTWARE"). By exercising your rights to use the SOFTWARE, you agree to be bound by the terms of this EULA. If you do not agree to the terms and conditions of this EULA, you may not use the SOFTWARE. **IF YOU DO NOT AGREE TO THE TERMS AND CONDITIONS OF THIS EULA, DO NOT CLICK THE "ACCEPT" BUTTON, AND DO NOT INSTALL OR USE ANY PART OF THE SOFTWARE.**

Carlson Software, Inc., referred to as "LICENSOR", develops and/or licenses proprietary computer programs and sells use licenses for such proprietary computer programs together with or apart from accompanying copyrighted material and documentation and;

End User desires to obtain the benefits thereof and, in return for which, is willing to abide by the obligations and fee agreements applicable to LICENSOR's use licenses in LICENSOR's proprietary computer programs. For good and valuable consideration, including but not limited to license grant in accordance with this Agreement by LICENSOR to End User's covenant regarding LICENSOR's proprietary rights, LICENSOR agrees to permit End User to utilize materials representing LICENSOR's product or products subject to the following terms and conditions:

- 1. License Grant:** Subject to the terms, conditions and limitations of this EULA, LICENSOR hereby grants End User a personal, limited, non-exclusive, non-transferable, license to utilize the Software Product you have purchased. The license granted in this EULA creates no license, express or implied, to any other intellectual property of Licensor, except for the specific Software Product which they have lawfully purchased from LICENSOR.

This EULA grants you the following rights: You may install and use one copy of the SOFTWARE PRODUCT, or any prior version for the same operating system, on a single computer. The primary user of the computer on which the SOFTWARE PRODUCT is installed may make a second copy for his or her exclusive use on a portable computer.

**Storage/Network Use.** You may also store or install a copy of the SOFTWARE PRODUCT on a storage device, such as a network server, used only to install or run the SOFTWARE PRODUCT on your other computers over an internal network; however, you must acquire and dedicate a license for each separate computer on which the SOFTWARE PRODUCT is installed or run from the storage device. A license for the SOFTWARE PRODUCT may not be shared or used concurrently on different computers.
- 2. Exclusive Source.** End User shall obtain all LICENSOR authorized product materials through LICENSOR or LICENSOR'S authorized representative and no other source. LICENSOR authorized product materials include, but are not limited to, manuals, license agreements and media upon which LICENSOR's proprietary computer programs are recorded. End User shall make no copies of any kind of any of the materials furnished by LICENSOR or LICENSOR's authorized representative, except as specifically authorized to do so in this EULA. End User is not entitled to make archival copies of those portions of LICENSOR's product(s) that are provided on a machine-readable media.
- 3. Proprietary Rights of Licensor.** End User agrees that LICENSOR retains exclusive ownership of the trademarks and service marks represented by its company name and logo and all of the documentation and computer recorded data related thereto. End User also agrees that all techniques, algorithms, and



processes contained in LICENSOR's computer program products or any modification or extraction thereof constitute TRADE SECRETS OF LICENSOR and will be safeguarded by End User, but in no event shall End User exercise less than due diligence and care in accordance with the laws of the country of purchase and International Law, whichever operates to best protect the interests of LICENSOR. End User shall not copy, reproduce, re-manufacture or in any way duplicate all or any part of LICENSOR products WHETHER MODIFIED OR TRANSLATED INTO ANOTHER LANGUAGE OR NOT, or in any documentation, or in any other material provided by LICENSOR in association with LICENSOR's computer program products regardless of what manner of storage and retrieval the product exists, except as specified in this Agreement and in accordance with the terms and conditions of this Agreement which remain in force. End User agrees that in the event End User breaches this EULA, End User will be liable for damages as may be determined by a court of competent jurisdiction.

4. **Restrictions.** End User's rights and obligations under this EULA are nonexclusive and personal in nature, and the intellectual property Licensor grants to End User is subject to applicable law other than bankruptcy law. End User may not transfer or assign the SOFTWARE, rights under this EULA or accompanying user documentation, or any updates of the SOFTWARE which may be provided under this EULA, to a third party unless End User receives written consent from Licensor at least 30 days prior to the completion of transfer. Licensor reserves the right to deny transfer or assignment if, in its sole discretion, Licensor determines the transfer not to be a necessity. Whether or not a transfer or assignment is allowed shall be determined in Licensor's sole discretion after taking into consideration certain factors to find the existence of a necessity including, but not limited to, merger or acquisition of an entity, complete asset acquisition, change of control, severe economic hardship, severe loss of human resources or significant loss in business divisions, or winding down of entity affairs. If Carlson consents to a transfer, such transfer shall be allowed only as a one-time permanent transfer of this EULA and Software to another end user, provided the initial End User retains no copies or previous versions of the Software. The transfer must include all of the Software, including all component parts, any media and printed materials, any upgrades, this EULA, and any associated license key. The transfer may not be an indirect transfer, such as a consignment, rental or lease. No corresponding Maintenance Agreement rights shall transfer with the SOFTWARE transfer to the subsequent end user. Prior to the transfer, the subsequent end user receiving the Software from the initial End User must agree to all terms of this EULA, with the added condition that no further transfers to third parties are permitted for any reason whatsoever and shall agree to the terms and conditions of a new Maintenance Agreement with Licensor.

You may not reverse engineer, decompile, or disassemble the SOFTWARE or alter the images utilized in the SOFTWARE and user documentation. The SOFTWARE PRODUCT is licensed as a single product. Its component parts may not be separated for use on more than one computer. You shall communicate to any individual user in your facility that they are bound by the restrictions of this license agreement may not copy or alter the SOFTWARE for use outside End User's facilities.

Upgrades. If you purchase an upgrade of a SOFTWARE PRODUCT and you use it on different machine from one where upgraded SOFTWARE PRODUCT was used, use of original SOFTWARE PRODUCT must be discontinued and confirmed within 30 days. If such use is not discontinued, it is a material breach of this EULA and LICENSOR shall be entitled to all remedies available to it under this EULA, and under the laws of Kentucky, USA.

5. **Warranty.** THE PRODUCT IS PROVIDED "AS IS" WITH ALL FAULTS. TO THE MAXIMUM EXTENT PERMITTED BY LAW, LICENSOR HEREBY DISCLAIMS ALL WARRANTIES, WHETHER EXPRESS OR IMPLIED, INCLUDING WITHOUT LIMITATION IMPLIED WARRANTIES OF MERCHANTABILITY, FITNESS FOR A PARTICULAR PURPOSE, AND WARRANTIES THAT THE PRODUCT IS FREE OF DEFECTS AND NON-INFRINGEMENT, WITH REGARD TO THE SOFTWARE, AND THE ACCOMPANYING WRITTEN MATERIALS. YOU BEAR ENTIRE RISK AS TO SELECTING THE PRODUCT FOR YOUR PURPOSES AND AS TO THE QUALITY AND PERFORMANCE OF THE PRODUCT. THIS LIMITATION WILL APPLY NOTWITHSTANDING THE FAILURE OF ESSENTIAL PURPOSE OF ANY REMEDY. In any event, LICENSOR will not honor any warranty shown to exist for which inaccurate or incorrect identifying data has been provided to LICENSOR. The product(s) provided are intended for commercial use only and should not be utilized as the sole data source in clinical decisions as to levels of care.
6. **LIMITATION OF LIABILITY.** EXCEPT AS REQUIRED BY LAW, LICENSOR AND ITS DISTRIBUTORS, DIRECTORS, LICENSORS, CONTRIBUTORS AND AGENTS



(COLLECTIVELY, THE "LICENSOR GROUP") WILL NOT BE LIABLE FOR ANY INDIRECT, SPECIAL, INCIDENTAL, CONSEQUENTIAL OR EXEMPLARY DAMAGES ARISING OUT OF OR IN ANY WAY RELATING TO THIS EULA OR THE USE OF OR INABILITY TO USE THE PRODUCT, INCLUDING WITHOUT LIMITATION DAMAGES FOR LOSS OF GOODWILL, WORK STOPPAGE, LOST PROFITS, LOSS OF DATA, AND COMPUTER FAILURE OR MALFUNCTION, EVEN IF ADVISED OF THE POSSIBILITY OF SUCH DAMAGES AND REGARDLESS OF THEORY (CONTRACT, TORT OR OTHERWISE) UPON WHICH SUCH CLAIM IS BASED. THE LICENSOR GROUP'S COLLECTIVE LIABILITY UNDER THIS AGREEMENT WILL NOT EXCEED THE GREATER OF \$500 (FIVE HUNDRED DOLLARS) AND THE FEES PAID BY YOU UNDER THIS LICENSE (IF ANY).

7. Update Policy. LICENSOR may, from time to time, revise the performance of its product(s) and in doing so, incur NO obligation to furnish such revisions to any End User nor shall it warrant or guarantee that any revision to the SOFTWARE will perform as expected by the End User on End User's equipment. At LICENSOR's option, LICENSOR may provide such revisions to the End User.
8. Customer Service. Although it is the LICENSOR's customary practice to provide reasonable assistance and support in the use of its products to its customers, LICENSOR shall not be obligated to any End User to provide technical assistance or support through this Agreement and may at LICENSOR's sole election charge a fee for customer support.
9. Termination of End User License. If any one or more of the provisions of this Agreement is breached, the license granted by this Agreement is hereby terminated. In the event of such termination, all rights of the LICENSOR shall remain in force and effect. Any protected health information data of End User maintained on LICENSOR'S data base shall upon reasonable notice to End User and at the discretion of LICENSOR may be destroyed.
10. Copyright. The SOFTWARE (including, but not limited to, any images, photographs, animations, video, audio, music and or text incorporated into the SOFTWARE), and all intellectual property rights associated with it, whether exists in a tangible media or in an electronic image media is owned by LICENSOR and is protected by United States copyright laws and international treaty provisions and all other commonwealth or national laws. LICENSOR reserves all intellectual property rights in the Products, except for the rights expressly granted in this Agreement. You may not remove or alter any trademark, logo, copyright or other proprietary notice in or on the Product. This license does not grant you any right to use the trademarks, service marks or logos of LICENSOR or its licensors. You may not copy any user documentation accompanying the SOFTWARE.
11. Injunctive Relief. It is understood and agreed that, notwithstanding any other provision of this Agreement, LICENSOR has the unequivocal right to obtain timely injunctive relief to protect the proprietary rights of LICENSOR.
12. Entire Agreement. This Agreement constitutes the entire agreement between the parties and supersedes any prior agreements. This Agreement may only be changed by mutual written consent.
13. End User Agreement Acknowledgment. The End User hereby accepts all the terms and conditions of this Agreement without exception, deletion, alteration. End User acknowledges they are authorized to enter this agreement on behalf of any organization for which the license is sought. Any unauthorized use of LICENSOR products will be considered a breach of this Agreement, subject to liquidated damages and otherwise unlawful and willful infringement of LICENSOR's trade secrets and/or proprietary products.
14. Payment and Refund Policy. The use of the SOFTWARE herein is deemed a commercial use and under the terms of this license agreement End User shall not be entitled to any refund of purchase price. End User agrees to pay all user fees promptly. LICENSOR is authorized by End User to suspend any further access to SOFTWARE in the event fees are not fully paid. End user entity shall promptly pay any and all access and use charges incurred regardless of the end user. End user is responsible for protecting any pass word and user identity supplied to End User.
15. Loss/Theft/Misuse. End user shall promptly report to LICENSOR theft or other loss of any password and/or user identity required to access SOFTWARE. LICENSOR shall not be responsible for maintaining the integrity of End User data in the event that end user's data base is accessed and/or altered by an unauthorized end user due to the failure of licensed End User to protect its password or user identity. End User shall be responsible for any costs incurred by LICENSOR due to the negligence or reckless disregard of End User's failure to protect its password or user identity.
16. Civil/Criminal Investigation. End user shall fully cooperate with LICENSOR and or any person authorized by LICENSOR (including local, state, or federal law enforcement officials) to investigate any alleged theft, misuse or unauthorized use of SOFTWARE or data related thereto.





17. U.S. Government Restricted Rights. The SOFTWARE and documentation are provided with RESTRICTED RIGHTS. Use, duplication, or disclosure by the Government is subject to restrictions as set forth in subparagraph (c)(1)(ii) of the Rights in Technical Data and Computer Software clause at DFARS 252.227-7013 or subparagraphs (c)(1) and (2) of the Commercial Computer Software-Restricted Rights at 48 CFR 52.227-19, as applicable.
18. Governing Law. This EULA shall be governed and construed in accordance with the laws of the Commonwealth of Kentucky, USA.



## 2 Installation

This chapter describes the system requirements and installation instructions for Carlson SurvPC.

### 2.1 Using the Manual

This manual is designed as a reference guide. It contains a complete description of all commands in the Carlson SurvPC product.

The chapters are organized by program menus, and they are arranged in the order that the menus typically appear in Carlson SurvPC. Some commands are only applicable to either GPS or total station use and may not appear in your menu.

Look for the icons for either GPS mode and/or total station mode, found at the start of certain chapters. These icons will be located at the top (header) of these pages, or at the start of a chapter.

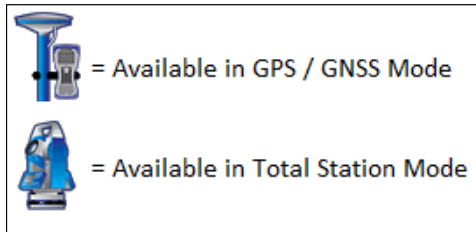

For some commands both icons will be shown, indicating that the SurvPC command can be used in both GPS and total station modes.

Many of the figures / images have been modified for proper formatting, please be aware your screenshots may differ slightly.



## 2.2 Installing SurvPC

1. Download or install CD/USB containing the SurvPCX.XX\_Setup.exe file.
2. Double-click on the .exe file to begin installation. The InstallShield Wizard for SurvPC will download installation files, the window will show as below:

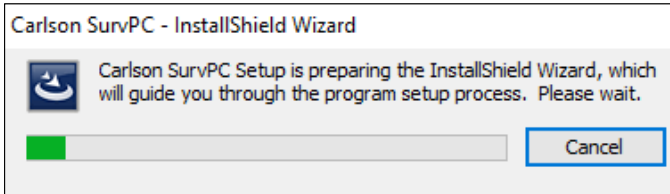

3. The Welcome to the InstallShield Wizard for Carlson SurvPC screen will show as below:

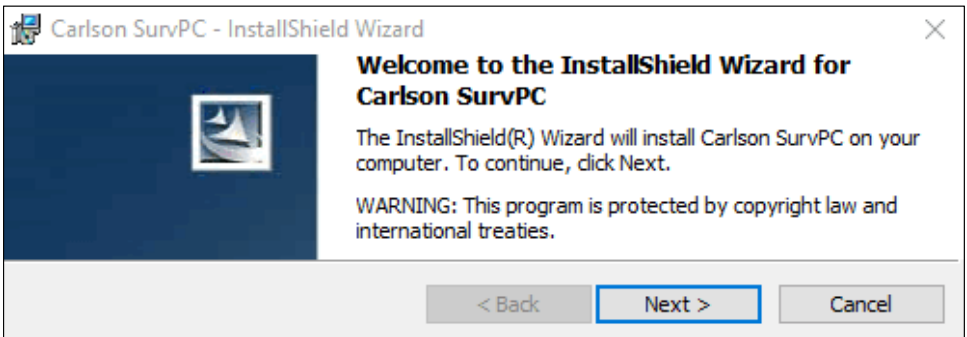



- The license agreement will be presented to the user next. Please read carefully and make appropriate selections. Click Next to continue.

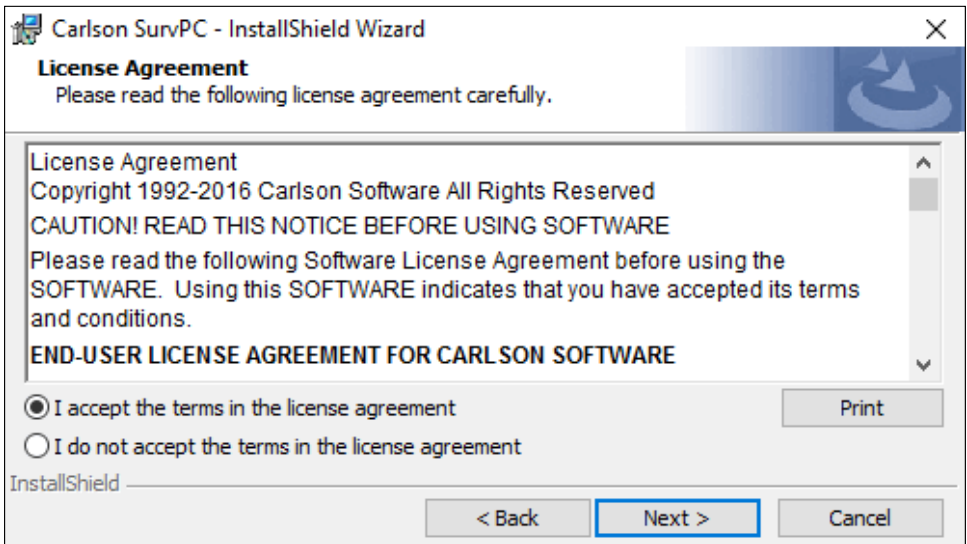

- The Ready to Install screen will be shown to the user. Installation settings selected will be presented. Click Back to review / edit selections. Click Next to continue.

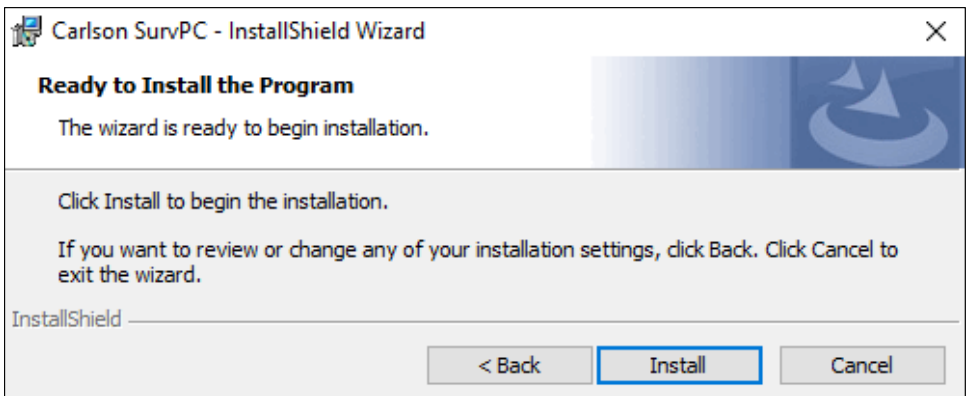



6. SurvPC will begin the installation process. This process typically takes < 1 minute.

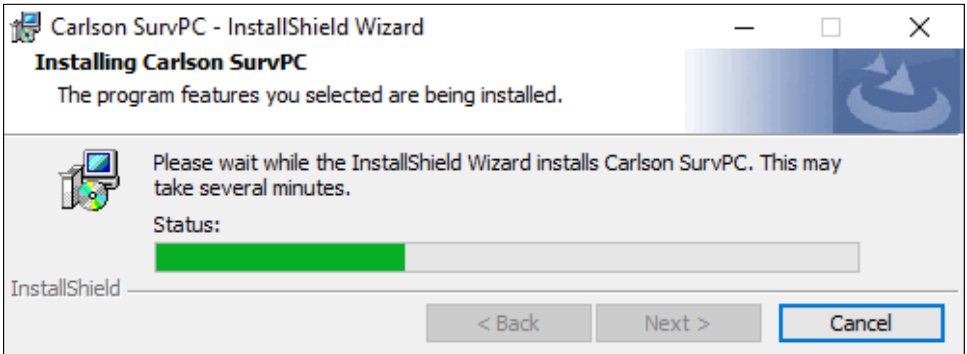

7. Installation Complete. The InstallShield Wizard will present the user with the following screen once installation is completed.

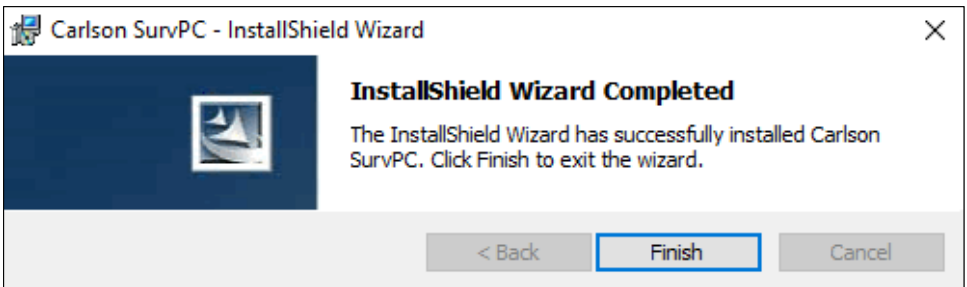



## 2.3 Authorizing SurvPC

The first time you start SurvPC, you are prompted to register your license of the software. If you do not register, SurvPC will remain in demo mode, limiting each job file to a maximum of 15 points.

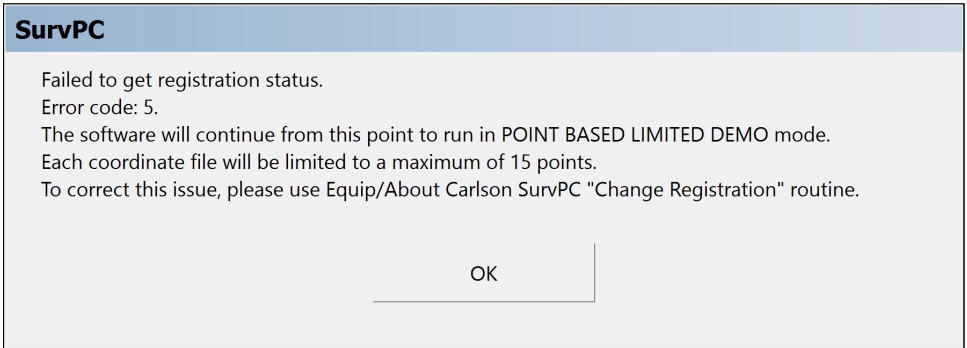

1. If you open SurvPC and it says you are in “Demo Mode”, tap Yes to register now. If you are at the Main menu of SurvPC already you can tap the Equip tab / About SurvPC and tap Change Registration to access this screen.

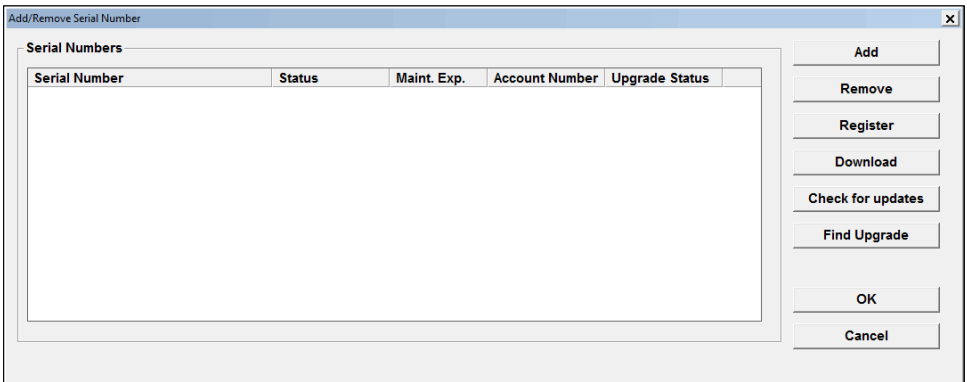



2. Click Register and type in your SurvPC Serial number.

Enter SurvPC Serial Number

Please enter the serial number supplied to you with the product.

Need a demo serial number? Call (606) 564 5028 or [Click Here](#) to get one via the internet.

**NOTE:** Windows Administrator rights are required to perform this step.  
Contact your local administrator if in doubt.

Serial Number

(for example: 1234567-123ABC12-123456-1234)

3. Now go to the SurvPC website at <http://www.SurvPC.com> to complete your registration via the Internet  
*PLEASE NOTE: If you do not have access to the Internet, you may fax your company name, phone number, email address, your SurvPC serial number, Hardware #1, Hardware #2 and the registration code to 606-564-9525. Your registration information will be faxed back to you within 48 hours.*
4. Click on the “[Registration Page](#)” link
5. Fill out this form with your Name and Company information / type in your SurvPC Serial number in the “Serial Number” box and make sure to include the Dashes
6. Fill in the Hardware #1 and Hardware #2 boxes with the Values displayed on your PC Screen {If you have trouble finding them click the “where is it located link”}
7. Choose the Reason for Install of “Initial Installation” if this is your First time registering SurvPC
8. Fill in the Registration Code from the screen of your PC and make sure to include the Dash
9. Click the Submit Registration Button
10. If this is your first time Registering SurvPC you may need to fill in some Contact Details, then click “Submit Contact Information”
11. If this is your first time Registering this PC with SurvPC please fill in the “Device Serial Number” and click the “Register Device to Complete Registration” button
12. Your Change Key will be displayed in a BOX in the Top Left of the SurvPC Registration summary. Type this change key in on the “Change Key” box on your PC then tap OK
13. You should receive a message saying “Successful SurvPC Registration!”. Tap OK

Your Carlson SurvPC Software is now Fully Registered. Your change key will also be emailed to the address that you submit. Keep a copy of this email for your permanent records.



## 2.4 Hardware Notes

A full list of hardware compatible with SurvPC 6.0 is found at <http://www.carlsonsw.com/products/data-collection/SurvPC>

## 2.5 Color Screens

SurvPC 1.21 or greater enables viewing of color. Any red, green, blue or other colored entities in DXF files will retain their color when viewed within SurvPC. Points will appear with black point numbers, green descriptions and blue elevations. Dialogs and prompting will utilize color throughout SurvPC.

## 2.6 Battery Status

**Battery Status of PC:** The icon that appears at the top of every screen is designed to indicate battery status of the PC itself.



## 2.7 Carlson Technical Support

Contact information for Tech Support for SurvPC is provided below:

<b>Carlson Software, Inc.</b>	<b>Carlson EMEA, BV</b>
Corporate Headquarters Maysville, KY, USA	Corporate Headquarters Almere, Netherlands
Tel (606) 564-5028 Fax (606) 564- 6422	Tel: +31 36 750 1781
<a href="http://www.carlsonsw.com">www.carlsonsw.com</a>	<a href="http://www.carlsonemea.com">www.carlsonemea.com</a>
<a href="mailto:support@carlsonsw.com">support@carlsonsw.com</a>	<a href="mailto:support@carlsonsw.com">support@carlsonsw.com</a>

## 2.8 Customer Service, Technical Support, Repair:

If you need assistance with your Carlson Software products, please call by telephone, or send an e-mail to the address above. U.S. support hours are Monday through Friday, 8:00 A.M. to 6:00 P.M. (EST, GMT -5 hours). EMEA support hours are Monday through Friday, 8:00 A.M. to 6:00 P.M. (GMT +1).





### 3 User Interface

This chapter describes the general user interface features of SurvPC.

The screenshot displays the SurvPC software interface, divided into two main sections: **Stake Road** and **STORE PTS**.

**Stake Road Panel:**

- Buttons:  Grade,  (checkmark),  (checkmark),  (checkmark),  (checkmark)
- Sta: 0+50.000 ft [Left Arrow] [Right Arrow] [Menu]
- Z: 999 ft
- Interval: 10 ft [Menu] [Play]
- CL Off: 0 ft
- Design Off: 0 ft [Menu]  L  R < -3%
- Stk Off: (H) 0 ft (V) 0 ft > 3%
- Graph: A profile view showing a red line representing the ground surface and a dashed vertical line for the centerline. The label "Slope Stake" is at the bottom right.

**STORE PTS Panel:**

- Buttons:  (checkmark),  (checkmark)
- Fixed(Sim)  14 110 ft **S**
- Graph: A plan view showing a circular area with a rectangular stake layout. Points 1 and 2 are labeled with 100.00. **A**
- Buttons: **O**, **C**
- Pt: 4 Desc: [Field]  0 ft
- Coordinates: N:418349.2843ft E:1779728.1652ft Z:397.2896ft **S**
- Accuracy: HRMS:0.050ft VRMS:0.098ft PDOP:3.20 TDOP:2.00



### 3.1 Graphic Mode

#### ICONS

SurvPC can be configured to show either the traditional letter Icons or graphical icons for several functions. To set this option, go to the Equip tab, select Configure and toggle the 'Use Graphic Icons' check box.

Letter icons	Graphical icons	Description
		This icon will Read a measurement (ALT-R).
		Total Station Only. This icon will Traverse to the measured point by advancing your setup (ALT-T).
		This icon will Store a point. This function is also performed via the Enter key. (ALT-S).
		This icon will lead to a dialog where the user can Average up to 999 epochs of GPS readings (ALT-A).
		This icon leads to Offset reading screens with options for keyed-in offsets as well as offsets taken by laser and hydrographic devices that measure distance only, or distance and azimuth (ALT-O).
		This icon will take you to the Configure dialog, also found on the EQUIP tab. Here you set many preferences in SurvPC such as the number of readings to average, function of the Store icon, and whether to display the Hgt/Desc prompt on Save (ALT-C).
		This icon will advance stake location incrementally to the Next point or station (ALT-N).
		This icon returns to the previous stakeout settings dialog where you can Modify the current design stake data.
		This icon allows the user to override the design Elevation (ALT-E).
		<b>OK:</b> This icon will accept the dialog.
		<b>Back:</b> This icon will return you to the previous dialog.
		<b>Exit:</b> This icon will return you to the main menu and dismiss any changes (ALT-X).
		<b>Standby/Search:</b> Robotics only. This status icon shows the instrument is in standby and when pressed, puts the instrument in search mode when then leads to lock mode when the prism is found.
		<b>Locked:</b> Robotics only. This icon shows that the instrument is locked on the prism, and when pressed, places the robotic total station in Standby mode, meaning it will suspend tracking mode (e.g. allows you to place the pole down, drive a stake, then resume work).



**EDM is On:** Robotics only. This icon shows that the instrument is continuously measuring distances and when pressed will stop the EDM.



**EDM is Off:** Robotics only. This icon shows that the instrument is NOT continuously measuring distances (not tracking) and when pressed will start tracking and enable the EDM on the total station. When in reflectorless mode, pressing this icon will begin continuous reflectorless measurements.



**Prism Mode:** This icon shows that the instrument is currently configured to read a prism and when pressed will switch the instrument to reflectorless mode.



**Reflectorless Mode:** This icon shows that the instrument is currently in reflectorless mode and when pressed will switch the instrument to prism mode.



**Laser Pointer Off:** This icon shows that the Laser Pointer is Off.



**Laser Pointer On:** This icon shows that the Laser Pointer is On. It is often used when doing reflectorless work and makes a red mark on the wall, floor or object being surveyed.

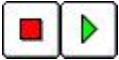

**Stop/Go:** This icon, inside of Auto by Interval, begins and pauses the action of recording points (ALT-G).



**Monitor/SkyPlot:** This icon will take you to the Monitor/SkyPlot screen for GPS status and Coordinate and Lat/Long display (ALT-D).



**Tripod:** This will take you to the Instrument Setup dialog. This dialog contains Backsight, Setup, Robotics and Remote Benchmark (ALT B).



**Zoom Extents:** This zooms the entire drawing to fit the screen.



**Zoom In:** Zooms in 25%.



**Zoom Out:** Zooms out 25%



**Zoom Window:** Zooms into a rectangular area that you pick on the map screen.



**Zoom Previous:** Zooms to the previous view. SurvPC remembers up to 50 views.



**View Options:** Displays the View Options dialog box, where you can control aspects of points such as the symbol, the style of the plot and the freezing or thawing of attributes such as descriptions and elevations. To avoid “point clutter”, you can even set it to show only the last stored point along with setup and BS. See the View Options section of this manual.



---

**Settings:** This icon leads to settings associated with the current command or option.

---

### **Pan**

You can also pan the screen simply by touching it, then holding and dragging your finger or stylus along the screen surface. Pan is automatic and needs no prior command.

### **View/Edit Points by Touch**

You can edit or delete any point by simply clicking on it graphically. In the Store Points command, clicking on a point also allows you to Re-Measure a point location or Delete a point, both in GPS and Total Station mode.

### **Text Mode**

The Text screen uses a large character size for easy viewing, and limits options to Monitor/Skypplot, Offset and Store. Select the Text mode by clicking on the Helmet in the upper left of the screen, in most active survey commands, choosing Text. You can return to the Graph view by tapping the Helmet icon and choosing Graph. You can also temporarily view your points on the screen by tapping the Map (upper right globe icon), then tap Back (Red X) to return to the text-based data collection screen. Note that the program will remember which screen you were in last (Graph or Text) and return to that mode of data collection automatically.



## 3.2 View Options

The graphic view has all of the standard zoom icons as well as a View Setting Icon in the lower left. This icon allows you to change the way the graphical items will be displayed. The View Setting Icon will show more options such as the "Alt-F" (store last point only) option when clicked during commands such as Store Points and Stake Points (active survey commands).

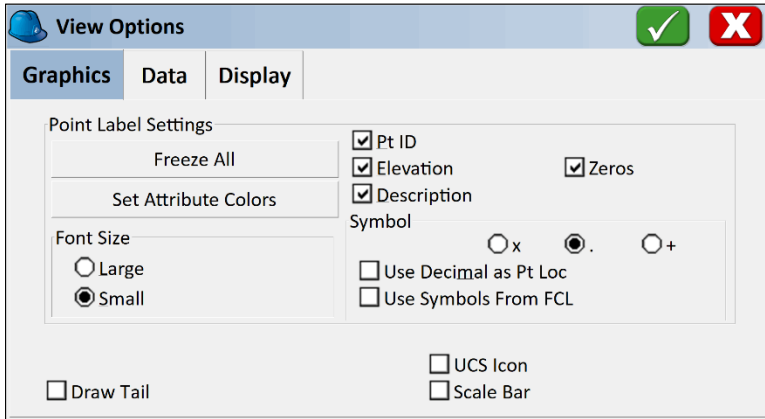

- **Freeze All:** This will freeze (hide from view) the point attributes (e.g. Point ID, Elevation and Description). Each attribute can be toggled off separately as well.
- **Font Size:** Points can be small (default setting) or large and bold for easier readability.
- **Use Decimal as Point Location:** This will adjust the text location so that the point location is the decimal point of the elevation. It applies if the "dot" symbol is used.
- **Use Symbols From FCL:** This will allow symbols loaded in a Feature Code List to be used.
- **Set Attribute Colors:** This button will allow users to specify the colors of the point text (color units only).  
-----The following options appear only when in active survey mode (e.g. Store Points, Stake Points) -----
- **Draw Tail:** This will augment the triangle icon to have a tail. The tail indicates direction and can assist in orientating a direction of travel (e.g. travel parallel to an existing line)
- **UCS Icon:** This shows the N/E icon on the graphic screen, for orientation.
- **Scale Bar:** This shows the Scale Bar on the graphic screen, for use if preferred.



The Data tab goes to a secondary screen which normally shows only the Intelligent Zoom option, but when selected from the Map screen (globe icon), also includes Traverse Defaults:

The screenshot shows two overlapping dialog boxes. The top dialog is titled 'View Options' and has three tabs: 'Graphics', 'Data', and 'Display'. The 'Data' tab is selected. It contains two checkboxes: 'Intelligent Zoom' (checked) and 'GIS Inspector' (unchecked). Below these is a text field labeled 'Traverse Defaults'. The bottom dialog is titled 'Traverse Defaults' and contains three sections: 'Prompt for:' with a checkbox for 'Instrument & Rod Height' (unchecked); 'Vertical Angle Prompt:' with four radio buttons: 'None' (selected), '0 Degrees Level', '90 Degrees Level', and 'Elevation Difference'; and 'Raw File:' with two radio buttons: 'On' (unchecked) and 'Off' (selected).

- **Intelligent Zoom:** When selecting points "From Map" in commands such as Inverse or Stake Points, the "Intelligent Zoom" allows you to pick the point from the screen in a condensed area of points, and the program will auto-zoom allowing you to pick again and obtain the precise point that you want. If Intelligent Zoom is off, you would instead see a list of points and must pick from the list or return to the Map screen and zoom in closer using the Zoom + or Zoom Window options.
- **GIS Inspector:** This will allow the GIS Inspector option.
- **Traverse Defaults:** The T for Traverse and S for Sideshot commands, within the Map screen, will prompt for instrument height, rod height and zenith angles as set in this dialog, and will optionally store to the raw file for processing. This allows for very fast manual entry of raw field data.



### 3.3 Quick Calculator

From virtually any dialog entry line in the program, the “?” command will go to the Calculator routines and allow copying and pasting of any selected calculation result back into the dialog entry line.

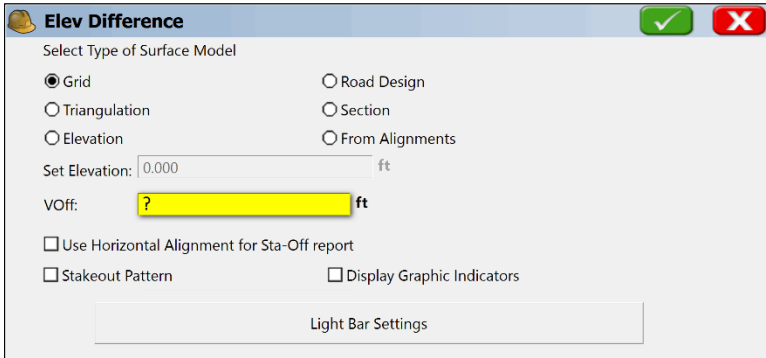

For example, grading a site that had 4 subgrades with a modeled top surface, you need to grade to the lowest subgrade surface with a vertical offset of  $(0.12+0.15+0.33+0.25)$ . Quickly obtain the value by entering “?” in the Vertical Offset field within the Elevation Difference dialog, as shown above.

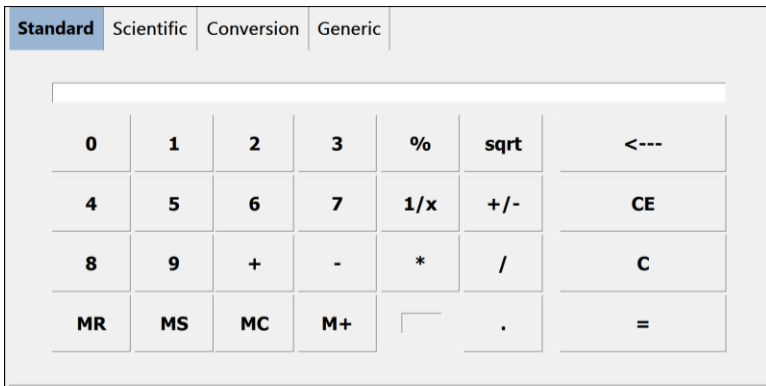

This leads immediately to the Calculator dialog, with its four tabs, or options, many with sub-options. Using the Standard tab, we can enter  $0.12+0.15+0.33+0.25$  and then “=”. Then select the Copy button, which places the value in the banner line at the very top of the screen. Then choose Paste to paste the value back into the Vertical Offset dialog edit box. Change the sign to “-” for negative, as needed. Calculations can also be done directly from the edit box within the Vertical Offset dialog. You could enter “19.5 in” for inches, which would auto-convert to feet or the current units setting. In this same edit box, you could also enter  $19.5/12$ , which would do the division directly in the edit box.



### 3.4 Hot Keys / Hot list / Helmet Menu

The ALT key commands take the form ALT-C (Configure Reading) or ALT-N (Next Point). The ALT key and the subsequent "Hot Key" ("C" or "N", as mentioned here) can be entered at nearly the same time or with any delay desired. If you press ALT and delay the entry of the hot key, you will see a text instruction: "Waiting for HotKey... Press Alt again to return". A second ALT returns to the previous position in the program without executing any command. If in the main menu, use the first letter of the tabbed commands (E for Equip, S for Survey, etc.) to go directly to those commands as an option to tapping the screen.

#### List of Hot Key Commands Activated by ALT

Many of the hot keys work only within related data gathering commands, as opposed to working from the main menus. Hot Keys vary by command. For example, in the Store Points screen, the hot keys are as follows.

- **ALT-R:** Read (Total Station Only)
- **ALT-S:** Store (or Shot/Store)
- **ALT-O:** Offset
- **ALT-C:** Configure Reading
- **ALT-B:** Backsight (Total Station Only)

Here is a list of other common hot keys:

- **ALT-E:** Target Elevation — From the stakeout screen in any Stakeout Line/Arc command, Offset Stakeout, Elevation Difference and virtually all stakeout commands except Stakeout Points, ALT-E will allow the user to enter an alternate design elevation different from the computed current design elevation. The screen prompt appears below:

Override design elevation  
Design El: 10.0000  
Set El to:

- **ALT-F:** Foresight Only Toggle. When in the Store Points graphic screen and taking new shots, ALT-F will freeze all but the setup point number, backsight point number and current foresight shot. This is helpful when points are densely located. Alt F again returns to the full point plot. Linework remains. In GPS Mode, Alt-F hides (freezes) all points, but shows a solid square symbol for the last GPS-measured point.
- **ALT-H:** Help. Takes you to the Help menu, where available.
- **ALT-I:** Inverse. Does a quick inverse, and upon exit, returns you to the command you were in. Inverse is also accessible from the Helmet in the upper left of the screen, in many commands including Store Points.





- **ALT-J:** Joystick. Applies only to robotic total station. Takes you to the Settings option. ALT-J typically only functions if you are configured for a robotic total station. ALT-J will work from within data gathering commands, most stakeout commands (e.g. Stake Points) and from the main menus.
- **ALT-L:** List, as in Feature Code List. When entered in any Description field, this will recall the Feature Code List, which displays the characteristics (layer/linework) of the feature code. This serves not only as a way to select the code and apply it to the description, but it also serves as a handy reminder of the code's properties. Helmet-Codes also goes to the Feature Code List.
- **ALT-M:** Map Screen. ALT-M will switch to the map screen.
- **ALT-N:** Next. Moves you to the Next point or station in the Stakeout commands.
- **ALT-T:** Traverse. Takes a reading and advances the setup to the measured point. The instrument setup dialog is presented for verification. Applies when in the Store Points routine.
- **ALT-V:** Shortcut to View the Raw Data, Point Data, Feature Codes and Cutsheets.
- **ALT-W:** Write a Note anytime with this command. Notes store to the Raw File.
- **ALT-X:** Shortcut to Exit most commands. Similar to Esc (escape key).
- **?:** The '?' character can be used in any field that requires a numerical entry to access the Calculator. (The Sokkia SDR8100 is an exception. This device uses the '=' symbol.)

### List of Commands Shown in the Helmet Menu

In most measurement screens, you can also select the SurvPC Helmet icon at the top left to access the hot list of shortcuts to other routines. Depending on what commands you are in, or if a Bluetooth device is involved (Reconnect option), the Helmet options appear as shown:























 <b>Help</b>	<b>Alt+H</b>	 <b>Map</b>	<b>Alt+M</b>
 <b>View Data</b>	<b>Alt+V</b>	 <b>View Data</b>	<b>Alt+V</b>
 <b>Points</b>	<b>Alt+P</b>	 <b>Points</b>	<b>Alt+P</b>
 <b>Inverse</b>	<b>Alt+I</b>	 <b>Inverse</b>	<b>Alt+I</b>
 <b>Write Note</b>	<b>Alt+W</b>	 <b>Write Note</b>	<b>Alt+W</b>
 <b>Feature Codes</b>	<b>Alt+L</b>	 <b>Feature Codes</b>	<b>Alt+L</b>
 <b>Calculator</b>	<b>Alt+K</b>	 <b>Calculator</b>	<b>Alt+K</b>
 <b>Reconnect</b>		 <b>Reconnect</b>	
 <b>Carlson Cloud</b>		 <b>Freeze Points</b>	<b>Alt+F</b>
 <b>Advanced Settings</b>		 <b>Text</b>	<b>Alt+Y</b>
 <b>Minimize</b>		 <b>Help</b>	<b>Alt+H</b>

Figure 1: Helmet Menus - Main Menu (Left) - Map Menu (Right)

- **Help:** This is a Help Index. If loaded to the SurvPC module, it will launch to HTML pages of this user manual.



- **View Data:** This allows the user to view the current data sets: Either Raw Data or Cutsheets.
- **Points:** This allows viewing and editing of the current point list. This is the same as File – Points.
- **Inverse:** This allows for the inverse to be run on stored points. Select the 2D or 3D type of inverse to be calculated along with the output syntax to be used. The point may be selected from the map, from a point list, or simply typed in the dialogue box.
- **Write Note:** This allows the user to write and save a note.
- **Feature Codes:** This allows the user to quickly enter the [Feature Code List](#) command. This is the same as File – Feature Code List.
- **Calculator:** This launches the SurvPC [Calculator](#) application.
- **Reconnect:** This is quick way to reestablish a lost Bluetooth connection.
- **Carlson Cloud:** This will take the user to the [Carlson Cloud](#) Login page.
- **Freeze Points / Thaw Points:** This allows the user to quickly freeze and thaw points shown in live survey screens (Store / Stake Points).
- **Advanced Settings:** This will allow the user to see both Audible Prompted and Regional Settings.
  - **Audible Prompting:** The audible prompting feature can be enabled and configured.

**Audible Prompting**

Audible Prompting Enabled

Stakeout

Include Units  Prompt Angle

Prompt Cut/Fill

Notify Inside/Outside Tolerance

Prompt frequency in seconds:

Increase Frequency with Proximity

Notify instrument status change

- **Audible Prompting Enabled:** This will enable / disable the Audio Prompting Feature.
- **Include Units:** This will include units with each measurement. For instance: “*One Hundred Feet*” when enabled, “*One Hundred*” when disabled.
- **Prompt Angle:** This will include the angle if selected in Stakeout options (e.g. Bearing, Azimuth, and Deflection).
- **Prompt Cut/Fill:** This will include Cut / Fill values with the stake measurements.



- **Notify Inside/Outside Tolerance:** This will notify the user whether a current measurement is inside or outside of the preferred tolerance values.
  - **Prompt Frequency in seconds:** This is the time between spoken messages.
  - **Increase Frequency with Proximity:** This will grey out the 'Prompt frequency in seconds' dialogue box and automatically increase the spoken frequency as the user approaches the selected stake point.
  - **Notify Instrument Status Change:** Enabled, this will notify the user of an instrument status change, such as Fixed or Not Fixed for GNSS receivers.
- **Regional Settings:** This will allow the user to further modify the settings during a Proximity Stakeout.

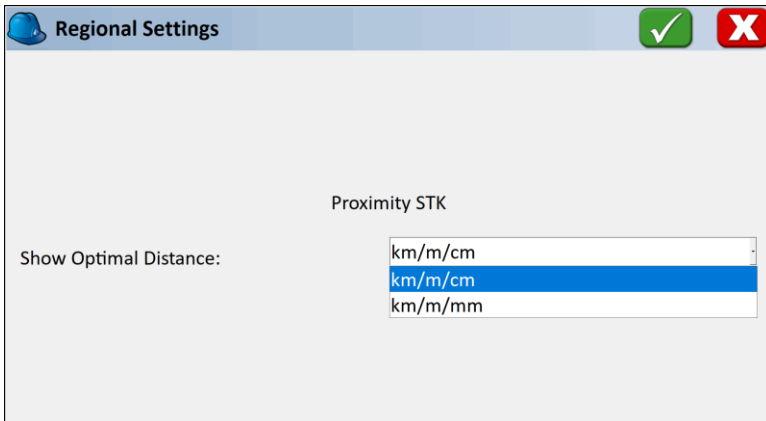

- **Text:** This will allow the user to switch the mode to Text View.
- **Minimize:** This will minimize SurvPC on the screen and allow the user to launch other PC programs.



While in any Topo (Store Points) or Stakeout routine, a number of features are accessible by pressing ALT, followed by the corresponding Hot Key. Below is a list of Hot Keys arranged by routine and equipment type.

### Action in Topo Mode Summary

Key	GNSS	Conventional TS	Robotic TS
A	Take Average Reading	Read and Store (All)	Read and Store (All)
B		Total Station Setup	Setup and Robotics
C	Configure Reading	Configure Reading	Configure Reading, Sets, Settings and Search
D	Monitor GNSS	Manual Read	Leica: Toggle EDM; Others: Manual Read
F	Freeze Points	Freeze Points	Freeze Points
G	Start/Stop Interval Recording		Start/Stop Interval Recording
H	Help	Help	Help
I	Inverse	Inverse	Inverse
J		Sokkia Motorized: Joystick	Joystick
K	Calculator	Calculator	Calculator
L	Feature Code List	Feature Code List	Feature Code List
M	View Map	View Map	View Map
O	Offset Point Collection	Offset Point Collection	Offset Point Collection
P	List Points	List Points	List Points
Q	Toggle Prompt for Hgt/Desc	Toggle Prompt for Hgt/Desc On and Off	Toggle Prompt for Hgt/Desc On and Off
R		Read	Read and Store
S	Store	Store	Store
T		Traverse	Traverse
V	View Raw File	View Raw File	View Raw File
W	Write Job Notes	Write Job Notes	Write Job Notes
X	Exit to Main Menu	Exit to Main Menu	Exit to Main Menu
Y	Toggle Graphics/Text Mode	Toggle Graphics/Text Mode (Helmet-Graph to return)	Toggle Graphics/Text Mode (Helmet-Graph to return)
Z	Zoom to Point	Zoom to Point	Zoom to Point



### Action in Stakeout Mode Summary

Key	GNSS	Conventional TS	Robotic TS
B		Total Station Setup	Total Station Setup
C	Configure	Configure Reading	Configure Reading
D	Monitor GNSS		Leica: Toggle EDM
E	Set Target	Set Target Elevation	Set Target Elevation
F	Freeze Points	Freeze Points	Freeze Points
H	Help	Help	Help
I	Inverse	Inverse	Inverse
J		Sokkia Motorized:	Joystick
K	Calculator	Calculator	Calculator
L	Feature Code List	Feature Code List	Feature Code List
M	View Map	View Map	View Map
N	Next	Next Point/Station to	Next Point/Station to
P	List Points	List Points	List Points
R		Read	Read and Store
S	Store	Store	Store
V	View Raw File	View Raw File	View Raw File
W	Write Job Notes	Write Job Notes	Write Job Notes
X	Exit to Main	Exit to Main Menu	Exit to Main Menu
Y	Toggle	Toggle Graphics/Text	Toggle Graphics/Text
Z	Zoom to Point	Zoom to Point	Zoom to Point



## 3.5 Carlson Cloud

### Features of Carlson Cloud

The Cloud feature is accessible in the Helmet of SurvPC and SurvPC. It offers the following capabilities.

- Messaging from Office to Field Staff and Peer-to-Peer
- File Transfer from Office to Field Staff and Peer-to-Peer
- "Crew View"--viewing of Rover Positions in particular when using GNSS equipment on Grid Coordinates
- For SurvPC only, Data Storage into the Same Job File (CRD File) by multiple Survey Crews

### Set up a Company Account

For each company, an account can be established using the option New User. The first user in a company needs to establish the company key word, ideally something unique so there is little or no potential for other companies to log into the same name. Each user within the company should have their own name and password, as shown below:

The screenshot displays two windows from the Carlson Cloud application. The top window, titled "Cloud Login", contains a form with fields for "Username:" and "Password:". Below these fields are five buttons: "Log In", "New User", "Forgot User Name", "Forgot Password", and "Delete User". The bottom window, titled "Create new account", contains a form with fields for "Username:", "Password:", "Retype Password:", "Phone:", and "Email:". Below these fields are two buttons: "Create Company Key" and "Use Existing Company Key". Both windows have a red "X" button in the top right corner.

Once successfully logged in, you can select any other company member to message, and you can exchange files. Click the paper clip to attach a file and then tap Send. The recipient will obtain a notice and can download or discard the file.

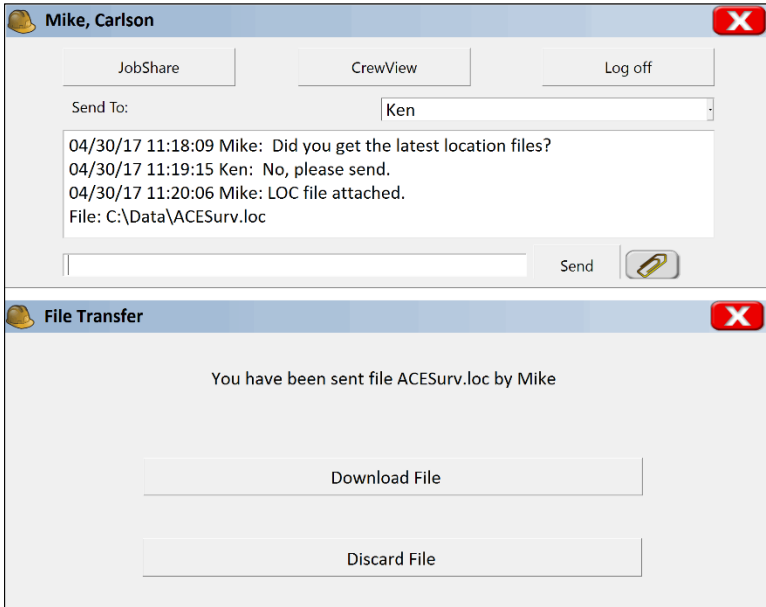

Tapping Crew View can lead to viewing of other crew members as shown below. They appear as Point ID's which you can calculate distance to (Inverse command) or navigate to, if needed. The positions of crew members update about once every 5 minutes.

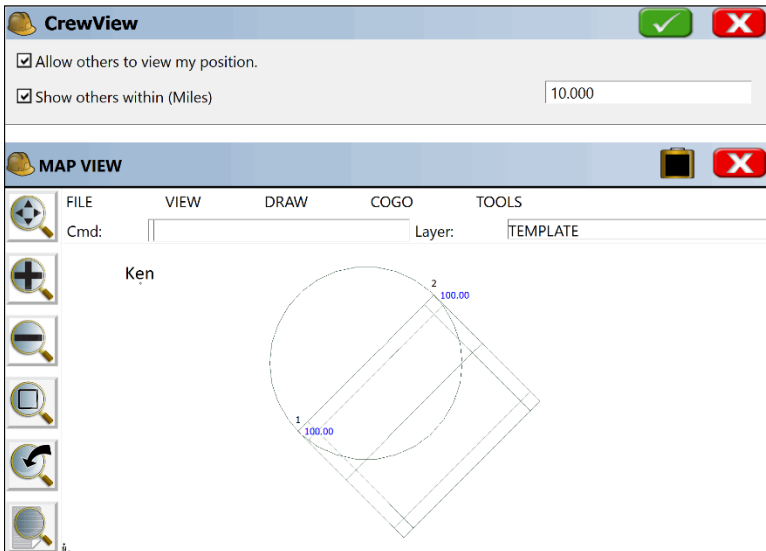



### 3.6 Instrument Selection

The user can switch between current instruments using the Instrument Selection flyout on the top bar of the SurvPC.

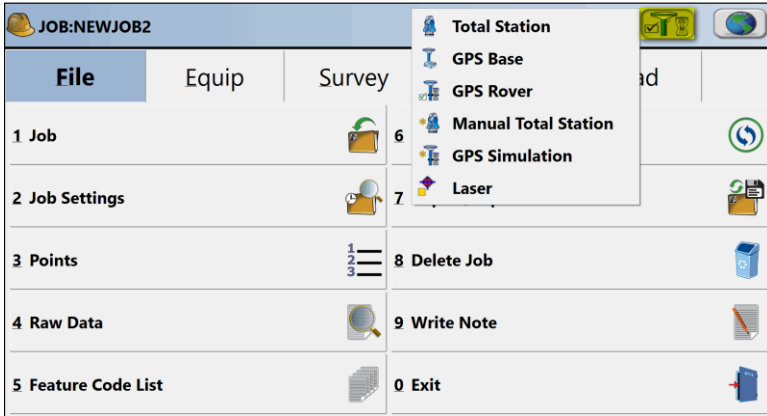





### 3.7 Input Box Controls

When point IDs are used to determine a value, the program will search for the point IDs in the current job. If not found it will then search in the control job, if active.

#### Formatted Distance/Height Entries

Entries for distances or heights that include certain special or commonly understood measurement extensions are automatically interpreted as a unit of measurement and converted to the working units as chosen in job setup. For example, a target height entry of 2m is converted to 6.5617 feet if units are configured for feet. The extension can appear after the number, separated by a space (2 m), or can be directly appended to the number (2m). For feet and inch conversion, the second decimal point informs the software that the user is entering fractions (See Below). Recognized text and their corresponding units are shown below:

- f or ft: US Feet
- i or ift: International Feet
- " or in: Inches
- cm: Centimeters
- m: Meters
- #.##.#: Feet and Inches (e.g. 1.5.3.8 = 1'5 3/8" either entry format is supported)

These extensions are automatically recognized for target heights and instrument heights, and within certain distance entry dialogs. Entries are not case sensitive. An entry of 1.5" or 1.5in would convert to 0.038 feet, for example.

#### Formatted Bearing/Azimuth Entries

Most directional commands within SurvPC allow for the entry of both azimuths and bearings. Azimuth entries are in the form 350.2531 (DDD.MMSS), representing 350 degrees, 25 minutes and 31 seconds. But that same direction could be entered as N9.3429W or alternately as NW9.3429. SurvPC will accept both formats. Additional directional entry options, which might apply to commands such as Intersection under Cogo, are outlined below:

If options in Job Settings are set to Bearing and Degrees (360 circle), the user can enter the quadrant number before the angle value.

Example  
120.1234  
--The result is N20°12'34''E.

Quadrants  
1 NE  
2 SE  
3 SW  
4 NW



In the case where Job Settings have been set for Bearing, and the user would like to enter an Azimuth, the letter A can be placed before the azimuth value and the program will convert it to a Bearing.

Example  
A20.1234  
*--The result is N20°12'34''E.*

In the case where Job Settings is set to Azimuth and the user would like to enter a bearing, the quadrant letters can be used before the bearing value.

Example  
NW45.0000  
*--The result is 315°00'00''.*

### Formatted Angle Entries

**Interior Angle:** The user can compute an angle defined by three points by entering the point IDs as <Point ID>, <Point ID>,Point ID>. The program will return the interior angle created by the three points using the AT-FROM-TO logic. Such entries might apply to the Angle Right input box in Store Points when configured to Manual Total Station.

Example  
1,2,3

Using the coordinates below, the result is 90°00'00''. Point 2 would be the vertex point.

Pt.	North	East
1	5500	5000
2	5000	5000
3	5000	5500

### Mathematical Expressions

Mathematical expressions can be used in nearly all angle and distance edit boxes. For example, within the Intersection routine, an azimuth can be entered in the form 255.35-90, which means 255 degrees, 35 minutes minus 90 degrees. Additionally, point-defined distances and directions can be entered with a comma as separator, as in 4,5. If point 4 to point 5 has an azimuth of 255 degrees, 35 minutes, then the same expression above could be entered as 4,5-90. For math, the program handles “/”, “\*”, “-“ and “+”. To go half the distance from 103 to 10, enter 103,10/2.

### Point Ranges

When ranges of points are involved, such as in stakeout lists, a dash is used. You can enter ranges in reverse (e.g. 75-50), which would create a list of points from 75 down to 50 in reverse order. For example, in Stake Points, you could enter 75-50 for the point



to stake, click "Add to List", then starting at point 75, stake 74, then 73, etc. by clicking N for Next.

## Survey Data Display Controls

### ANGLE

The angle control will display the angle as defined by the current settings in Job Settings.

Options are available for Azimuth (North or South) or Bearing combined with the option of Degrees or Grads.

#### **Format**

The display format of degrees uses the degree, minute, and second symbols. For the case of a bearing we display the quadrant using the characters N, S, W, E.

Example Bearing

N7°09'59"E

Example Azimuth

7°09'59"

All angular values entered by the user should be in the DD.MMSS format.

Example

7.0959

--The result is 7°09'59".

#### **Formulas**

Formulas can be entered for working with angles. The format must have the operator after the angle value.

Example

90.0000 \* 0.5

--The result would be 45°00'00"

### DISTANCE

The distance control will display the value using the current Job Settings unit. You can enter a formula using the mathematical operators as described above.

### INVERSE

You can compute a distance from a point-to-point inverse by entering <Point ID>,<Point ID>.

Example

1,2

Using the coordinates listed below, the result is 500'.

Pt.	North	East
1	5500	5000
2	5000	5000

### STATION

The station control will display the value using the current Job Settings format.



The same options described above for distance input boxes apply.

## SLOPE

The slope control will display the value using the current Job Settings format.

## 3.8 Keyboard Operation

Carlson SurvPC allows the user to operate the interface entirely from keyboard navigation, as well as touch screen navigation. The rules for keyboard navigation are outlined below:

### Controls

- **Button (Radio Buttons, Check Boxes and Standard Buttons)**
  - **Enter:** Select the button.
  - **Right/Left Arrows:** Move to the next tab stop.
    - **Right** [Tab]
    - **Left** [Shift+Tab]
  - **Up/Down - arrows:** Move to the next tab stop.
    - **Down** [Tab]
    - **Up** [Shift+Tab]
  - **Tab:** Move to the next tab stop.

In Menus like Job Settings, Tab Right and Tab Left move through the tab headings (New Job, System, Format, Options, Stake) along the top of the dialog, while the right and left arrows move up and down through the options within each tab.

- **Drop List**
  - **Enter:** Selects the highlighted option within each drop list.
  - **Right/Left Arrows:** Move to the next tab stop.
    - **Right** [Tab]
    - **Left** [Shift+Tab]
  - **Up/Down - arrows:** Move through the list items.
  - **Tab:** Move to the next tab stop.
- **Edit Box**
  - **Enter:** Move to the next tab stop. For any measurement screen, if focus is in the description edit box, take a reading. For all other edit boxes, ENTER moves through the tab stops.
  - **Right/Left Arrows:** Move through the text like standard windows.
  - **Up/Down - arrows:** Move to the next tab stop.
    - **Down** [Tab]
    - **Up** [Shift+Tab]
  - **Tab:** Move to the next tab stop.
- **Tab**
  - **Enter:** Move to the next tab stop.
  - **Right/Left Arrows:** Move through the tabs.
    - **Right** Next Tab



- **Left** Previous Tab
- **Up/Down - arrows:** Move to the next tab stop.
  - **Down** [Tab]
  - **Up** [Shift+Tab]
- **Tab:** Move to the next tab stop.



---

## 3.9 Abbreviations

Adr: Address  
AR: Angle Right  
Avg: Average  
Az: Azimuth  
Bk: Back  
Calc: Calculate  
Char: Character  
Chk: Check  
cm: Centimeter  
Coord(s): Coordinate(s)  
Ctrl: Control  
Desc: Description  
Dev: Deviation  
Diff: Difference  
Dist: Distance  
El: Elevation  
Fst: Fast  
ft: Foot  
Fwd: Forward  
HD: Horizontal Distance  
HI: Height of Instrument.  
Horiz: Horizontal  
Ht: Height or Height of Antenna with GNSS.  
HT: Height of Target.  
ID: Identifier  
ift: International Foot  
in: Inch  
Inst: Instrument  
Int: Interval  
L: Left  
m: Meter  
No: Number  
OS: Offset  
Prev: Previous  
Pt: Point ID  
Pts: Points  
R: Right  
Rdg: Reading  
SD: Slope Distance  
Sta: Station  
Std: Standard  
Vert: Vertical  
ZE: ZenithFile

---



## 4 File

This chapter provides information on using the commands from the File menu.

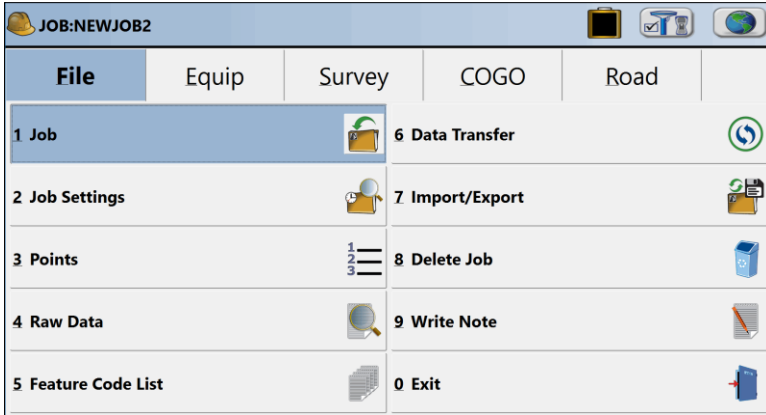



## 4.1 Job



This command allows you to select an existing coordinate file for your job or to create a new coordinate file. The standard file selection dialog box appears for choosing a coordinate file, as shown in the next figure. Buttons for moving up the directory structure, creating a new folder, listing file names and listing file details appear in the upper right corner of the dialog box.

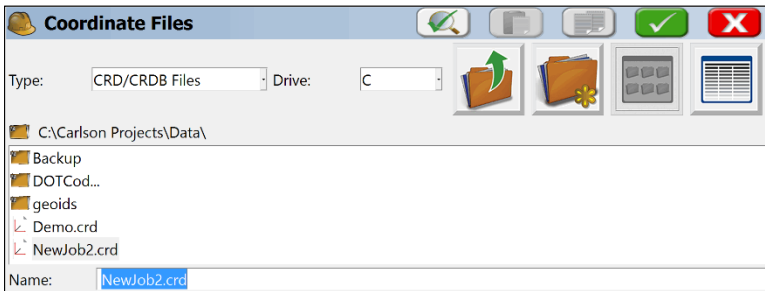

All data points you collect are stored in the coordinate (.crd) file you select or create. The .crd file extension will automatically be appended to the file name. If you add a "b" to the "crd", you will select the database format of the crd file, which enables Point IDs up to 255 characters and Point Descriptions up to 255 characters. Then future jobs will default to the ".crdb" format. If you return to the "crd" format (standard), point IDs are limited to 9 characters and descriptions to 31 characters. Once in any format (crd versus crdb), that particular format becomes the default on new jobs, until changed. Point ranges in a crdb file are presented to the user from highest number to lowest (e.g. 10, 9, ..., 1). SurvPC additionally permits the direct loading of ArcMap doc files (.mxd extension) and Microstation drawing files (.dgn extension). With SurvPC, these alternate file types are loaded by selecting the options under "Type" in the upper left.

### Select Existing Job

To select an existing job, browse to and select an existing file, then select OK (green check).





### **Create a New Job**

To create a new job, simply enter a new name and select OK. You can control where your job is saved by browsing to the desired folder where the job is to be created before entering the new name and selecting OK. You can also create a new folder for this new file name. Following job creation, you will be asked to enter in Job Attribute information. This feature lets you set up prompting for each new job with job-related attributes like Client, Jurisdiction, Weather Conditions and the like. The information is stored in the raw file. This is discussed in detail in the Job Setting section.

### **Copy and Paste Job**

The Copy icon at the top of the dialog allows you copy an existing file and then paste it with the Paste icon into a different directory, as selected.

*Note: If you key in a coordinate file that already exists, it will load the file instead of overwriting it with a new file. The benefit of this feature is that you cannot accidentally overwrite an existing coordinate file from within Carlson SurvPC.*



## 4.2 Job Settings (New Job)



This tab allows you to configure how all new jobs will be created.

- **Prompt for First Pt:** This option specifies whether or not SurvPC will prompt you to specify a starting point when starting a new job. If enabled, you specify the default starting point coordinates in the left column. This applies for total station use only.
- **Prompt for Units:** This option specifies whether or not SurvPC will prompt you to set the units when you start a new job.
- **Use Last Job Localization:** If this feature is enabled, each new job will use the previous job's localization file and project scale. If this feature is disabled, each new job will start out with no localization and a project scale of 1.0. The default value is off.
- **Attach Last Control Data:** This allows the user to use the same control file on all new jobs. With this option off, the control file will automatically be deactivated during new job creation.
- **Cutsheets:** Cutsheets are reports of cuts and fills based on stakeout (setout) commands. Auto-Save by job will automatically create cutsheet files (in the last format used) for each new job. If your job was named Macon1.crd, then the first 3 cutsheet files created would be Macon1-Pt.txt (for non-alignment, point-only stakeout), Macon1-CL.txt (for stakeout involving alignments) and Macon1-Sl.txt (for slope staking). Auto-Save by Job & Date will include the date in the job name. Recall Previous will allow the user to use the same cutsheets on all new jobs. With Manual, the control file will automatically be deactivated during new job creation and you will need to create cutsheet files within the Stake tab of Job Settings. Cutsheets normally store in ASCII (\*.txt) format but can store in EXCEL (\*.csv) format if selected within Job Settings, Options.



- **Use Template DXF:** This allows users to create an empty DXF file that contains all of the layers and colors that will be used and displayed in the field. The feature works well with use of Feature Codes for linework. If you designate code 201, for example, as a pavement edge in the layer BitPav, you could make a blank DXF drawing with BitPav layer created, set to color blue. Then using that "template dxf" file, everytime you code a 201, you will see the blue linework as an extra confirmation of correct coding. This color-coding could be repeated for other often used layers.
- **Define Job Attributes:** This lets you set up prompting, for each new job, for job-related attributes like Client, Jurisdiction, Weather Conditions, Party Chief and other notes. These will prompt when each new job is started, and the attributes and entries will appear in the raw file (.rw5) file. Select Add to enter new attributes.

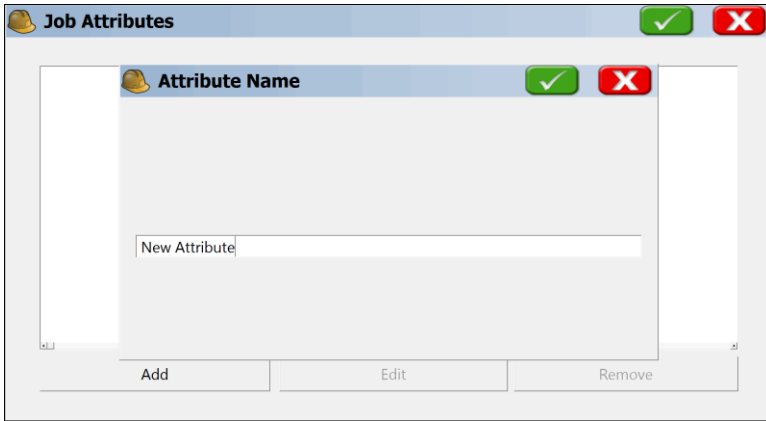



## 4.3 Job Settings (System)



This tab allows you to define the units for the current job.

**Job Settings** [Green Checkmark] [Red X]

New Job **System** Format Options Stake

Distance: US Survey Feet

Display Input: Decimal Feet

Angle: Degrees, Minutes, Seconds Time: Local

Lat/Lon: Degrees, Minutes, Seconds

Zero Azimuth: North Edit Projection List

Projection: USA/NAD83/KY North

- **Distance:** Select the units that you want to use. Choices include US Feet, International Feet, and Metric. If US Feet or International Feet is selected, you have the option to display distances as decimal feet (Dec Ft) or Feet and Inches (Inches). This is a display property only and will not change the format of the data recorded to the raw file. Once distance units are selected for a new job (meters vs feet), they cannot be changed, except for selection of decimal feet versus feet and inches in the case of measurement in feet. If you want to select another unit of measurement, create a new job and if necessary, import the coordinates, linework and symbols as desired. Convert entities and points between meters and feet using options within Cogo, Transformation, Scale or Align.
- **Angle:** This offers the option of degrees (360 circle, 60 minutes to a degree and 60 seconds to a minute), decimal degrees and gons (also referred to as grads- 400 circle and fully decimal). An angle of 397.9809 gons is equivalent to 358 degrees, 10 minutes and 58 seconds. (Note: you can verify this in Cogo, Calculator, Conversion tab). Angle measurement in Mils is also provided for military applications, where each mil represents 1/6400 of a circle (standard in NATO countries). The Angle Unit configuration impacts commands such as Inverse, Traverse, Sideshot, Input-Edit Centerline and other commands where a direction is displayed or entered.
- **Lat/Long:** Options are for degrees, minutes, seconds and decimal degrees, impacting all latitude and longitude displays and entries, such as in Equip, Localization.
- **Zero Azimuth Setting:** Allows you to specify the direction for zero azimuth, North or South.



- **Edit Projection List:** You can create a short list of commonly used projections that appear in the pulldown list. This is done by selecting projections from Predefined choices, per the menu option below. Predefined choices include NAD 27 and NAD 83 for the United States and UTM for projections around the globe, as well as individual country projections. Although UTM selections include every UTM zone spanning the globe, one advantage of the UTM Automatic Zone Selection is that your local Latitude and Longitude will be used to automatically set the zone, in case you do not know which UTM zone to use. You can also Add User Defined projection systems, where you enter the New System name, choose the Projection type from an extensive list, then enter all the information requested such as False Northing, False Easting, and the items within "New Datum".

The screenshot displays two windows from a software application. The top window, titled "Coordinate Projection", has a green checkmark icon in the top right corner. It contains a table with two columns: "Name" and "Source". The first row is highlighted in blue and contains "USA/NAD83/KY North" and "Carlson". Below the table are four buttons: "Delete", "Add Predefined", "View", and "Add User Defined". The bottom window, titled "New System", has a green checkmark icon and a red "X" icon in the top right corner. It contains several input fields: "System:" with "New System", "Projection:" with "Transverse\_Mercator", and "Datum:" with "Load File" and "User Defined" buttons. Below these are four rows of input fields: "Scale Factor:" (1), "C. Meridian:" (0), "Zone Width:" (6), and "Lat. of Origin:" (0). To the right of these are two columns of input fields: "False Northing:" (0 m) and "False Easting:" (0 m).

*Note: The Projection selection applies primarily to GPS work and your localization file. It enables automatic calculation of scale factors for grid to ground and ground to grid, for example (See Localization). However, the Projection can also apply to total station work. When you do any processing of your data within the Raw Data option (File Menu), there is an option "Reduce to Grid Coordinates". If this option is turned on, then the position on the projection is calculated for each point in the traverse and for each sideshot, and leads to a specific grid factor. The grid factor, combined with the elevation factor, leads to computation of the combined factor, which is applied to each traverse and sideshot. The program then calculates the fieldwork at sea level on the projection (ground to grid). This can improve your closures especially when traversing from one known grid system monument to another. Selecting and applying the correct projection is also useful when trying to match total station measurements (often located on the ground) to GPS-based survey work (typically located on the grid, at sea level).*



## 4.4 Job Settings (Format)



This tab allows you to select the viewing format of the data displayed and entered in the current job.

The screenshot shows the 'Job Settings' dialog box with the 'Format' tab selected. The dialog has a title bar with a yellow bell icon, the text 'Job Settings', and two buttons: a green checkmark and a red 'X'. Below the title bar are four tabs: 'New Job', 'System', 'Format', 'Options', and 'Stake'. The 'Format' tab is active. The settings are as follows:

Setting	Value
Coordinate Display Order:	North,East
Angle Entry and Display:	Azimuth
Horizontal Observation Display:	Angle Right
Vertical Observation Display:	Zenith Angle
Distance Observation Display:	Slope
Slope Entry and Display:	Percent
Station Display: (e.g. 1+00.000)	+00.000

- **Coordinate Display Order:** This option allows you to display coordinates with the order of North *then* East or East *then* North.
- **Angle Entry and Display:** Options are Bearing or Azimuth. This applies to numerous commands, such as prompting and displays in Sideshot, Traverse (the backsight as azimuth or bearing), Intersections, and Inverse.
- **Vertical Observation Display:** Allows you to set the default prompting to Zenith (0 degrees up, 90 degrees level), Vertical Angle (90 degrees up, 0 degrees level) or Elevation Difference (up is positive in absolute units, down is negative). Normally combine Elevation Difference with Horizontal Distance. If combined with Slope Distance, the non-zero Elevation Difference will be used to compute the equivalent zenith angle and will reduce the Slope Distance to a lesser Horizontal Distance. (Applies to entries in Manual Total Station mode).
- **Distance Observation Display:** Options are Slope or Horizontal. This applies to the values displayed from total station readings.
- **Slope Entry and Display:** Whenever slopes are reported or prompted, you have the option to specify the default in Percent, Degrees or Ratio. Some commands such as 3D Inverse will automatically report both slope and ratio and are unaffected.



- **Station Display:** This option impacts the display of centerline stationing, sometimes referred to as “chainage”. In the U.S., for example, roads designed in feet are “stationed” by every 100 feet, so that a road at linear position 14280.5 is given a station of 142+80.50. Metric roads in the U.S. are often stationed by kilometers, where the same road position has a station of 14+280.500. You can configure the placement of the “+” as desired, independent of your configuration for metric vs feet units. You can also configure for a purely decimal display of stationing/chainage, as in 14280.500. This display form shows up in such commands as Input-Edit Centerline, within the Start Station dialog box. Please note that you should still input the stationing in purely numeric form, without the “+” convention. Only the display is impacted by this option. Note how the example within parentheses changes with each selection.



## 4.5 Job Settings (Options)



This tab allows you to set configuration options for the current job.

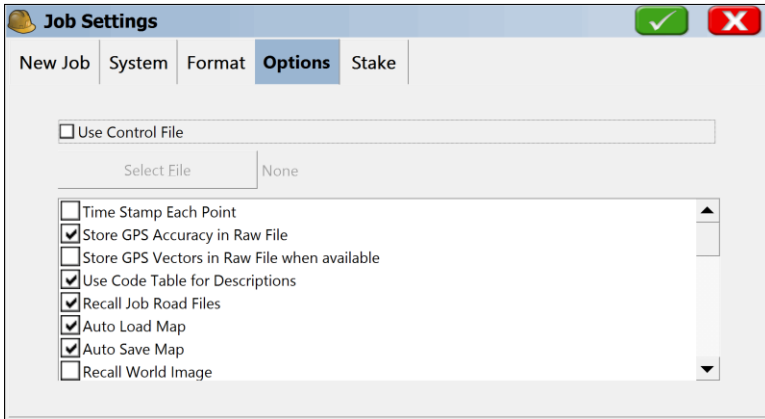

- **Use Control File:** The control file is used for selecting and using points that don't exist in your current working file.
- **Select File:** Select the control file to use. The chosen file appears, and will remain as the default control file, even when the control file option is disabled (in which case it is grayed out).

**General Rule:** Carlson SurvPC will always look for the defined point in the current working file first, and then the control file. If the point is not found in either file, a warning that the point does not exist will be displayed. You can force a point to come from the control file or the current file, regardless of settings, by using the List icon to the right of the point ID input box. While in the point list selection window, select the Control file button prior to selecting the desired point.

**Stakeout Option:** Control files work similarly in stakeout. However, you can go to the STAKEOUT tab in Job Settings and set the program to give priority to the control file points when duplicate points exist. If this option is turned on, and the selected point is found in both files, you will actually be staking out the point from the control file.

**Coordinate File Rule:** At no time, will a point be automatically copied from the control file into the current file. This allows users to avoid large gaps in coordinate files and eliminates the potential for conflicting points.

**Raw Data File Rule:** Any time a point is occupied, the occupation record (OC) is written to the raw file for processing purposes. There will not be an SP record written for control file points, only an OC record. Note that if the raw file is reprocessed, the point will be written to the current coordinate file.





Options Available	
<input type="checkbox"/> Time Stamp Each Point	<input type="checkbox"/> Allow "Navigate To" in Store Points
<input checked="" type="checkbox"/> Store GPS Accuracy in Raw File	<input type="checkbox"/> Show TEXT/VIEW Buttons
<input type="checkbox"/> Store GPS Vectors in Raw File when available	<input checked="" type="checkbox"/> AutoFit Positions/Measurements displayed in the bottom bar
<input checked="" type="checkbox"/> Use Code Table for Descriptions	<input type="checkbox"/> Use smaller font to display Positions/Measurements in the bottom bar
<input checked="" type="checkbox"/> Recall Job Road Files	<input type="checkbox"/> Log Real Time STK Line/Arc Data
<input checked="" type="checkbox"/> Auto Load Map	<input type="checkbox"/> Log Real Time STK Line/Arc Data To COM Port instead FILE IO
<input checked="" type="checkbox"/> Auto Save Map	<input type="checkbox"/> Apply "GNSSAnalysis" to average identical GPS Pts: IDs or IDs+DESCs
<input type="checkbox"/> Recall World Image	<input checked="" type="checkbox"/> Auto Store Pick Points
<input type="checkbox"/> Allow Import .dxf/.dwg/Esri Options	<input type="checkbox"/> Store Rod Height as Notes
<input type="checkbox"/> Default Cutsheets to EXCEL(*.csv) files	<input type="checkbox"/> Include Pt blocks in the crt DXF, on Save
<input type="checkbox"/> Use Finnish NLS Store Points Style	<input type="checkbox"/> Allow GIS Data prompting for STK Pts
<input type="checkbox"/> Use SWC Store Points Style	<input type="checkbox"/> Tag Photo Info(Pts) in RW5
<input checked="" type="checkbox"/> Allow Stake Nearest Pt from Pts List	<input type="checkbox"/> Allow GIS Data to be Skipped(Hgt/Desc)
<input type="checkbox"/> Skip confirmation screen in NEXT STK Pts	<input type="checkbox"/> Write MO(Units Record) to RW5 As a Note

- **Time Stamp Each Point:** When enabled, a date and time stamp will be noted in the raw file beside each point. Raw files in Carlson SurvPC have a .RW5 extension and are nearly identical to the TDS .RW5 format. See the image below for simple SurvPC .RW5 file.

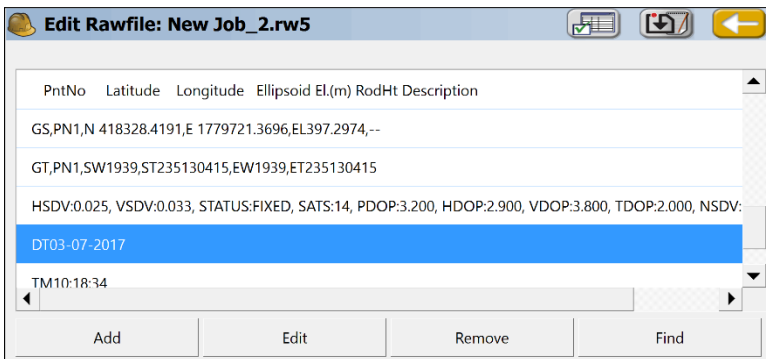

- **Store GPS Accuracy in Raw File:** This option is available when configured to any GPS equipment. If enabled, the horizontal and vertical quality as reported by the GPS will be stored to the raw file with each point. The terms may vary by receiver type: (e.g. HRMS/VRMS, HSIG/VSIG or CEP/SEP typically).



- **Store GPS Vectors in Raw File:** The GPS vectors option is a form of raw data for GPS measurements, similar to angle and distance data for total stations. The vectors refer to the distance and azimuth from the base receiver or virtual reference station base to the rover. These vectors can then be used by any Network Least Squares program such as Carlson SurvNet, which is part of Carlson Survey office software. They may also be utilized optionally in Post Processing, such as in the Carlson SurveyGNSS program. Finally, vectors are essential to utilize the GNSS Analysis feature within the Cogo Menu, Point Average. The vector option is available on most GNSS receivers, but not all. Many manufacturers are in the process, however, of adding access to the GNSS vectors allowing Carlson SurvPC to store the vectors in the raw file. Examples of receivers that provide access to the vectors include Altus, the Carlson Surveyor+ GPS, Topcon, Leica, Stonex S8 Plus, S9III, Trimble Promark SP80, Geomax Zenith 20, CHC and Satlab.
- **Use Code Table for Descriptions:** This feature activates feature code usage. If on, feature codes can be used to draw symbols and linework within specific layers. Special code icons also appear when "Hgt/Desc Prompt on Save" is on (within Equip-Configure). If "Use Code Table" is clicked off, use of feature codes is disabled and no linework or symbol drawing will occur. When clicked off, only the current descriptions used in the current job will appear. Most users will turn on the "Use Code Table" option and access the power of the feature codes. Only users who do not want linework and symbols and only wish to see the specific descriptions in their current, active job will benefit from turning off "Use Code Table". When clicked off, only the previously used descriptions within the active job appear for re-use by picking.

**Store Point**

Pt ID: 2  6.562 ft

Repeat Store  Avg Same Pt ID

N:418333.4595ft HSDV:0.027ft

E:1779723.0112ft VSDV:0.037ft

Z:390.7440ft PDOP:3.200

Desc: CP 

- **Recall Job Road Files:** This command only applies to Stakeout Centerline, Offset Stakeout, and Point Projection in the non-reading version of Carlson SurvPC. When enabled, this option will recall the last roading files (centerlines, profiles, templates, superelevation files, etc.) used in road stakeout. Routines in the Road menu such as Stake Road and Slope Staking will automatically recall the last-used roading files.



- **Auto Load Map and Auto Save Map:** Maps can be viewed in the MAP and Graphic views within Carlson SurvPC. These maps can be created by using the command IDXF which imports a DXF drawing file. AutoCad DXF formats 12 through 2010 are fully compatible and will import. Microstation DXF files and DXF files from other CAD programs will also work. Linework (referred to as polylines) can be produced within the MAP view by using the PL (polyline) command, or other commands such as Offset (O2 and O3). In addition, use of Feature Codes, where linework is associated with field codes such as EP for edge-of-pavement, will lead to the drawing of polylines in the Map view. These maps can then be auto-saved whenever you exit a coordinate file, and auto-loaded whenever you load a particular coordinate file. The maps are saved in DXF format. It is typical to enable both Auto Load Map and Auto Save Map if you want to auto-recall your latest map. If Auto Load Map is on and Auto Save Map is turned off, you will recall the map that was saved previously—when Auto Save Map was on. If you want to start your map from a clean slate (from the point plot only—which always appears in map view), you can turn off Auto Load Map and re-enter the program. Then add polylines, use IDXF to import maps (polylines), then click on Auto Save Map and Auto Load Map and you will store and recall only the new linework.

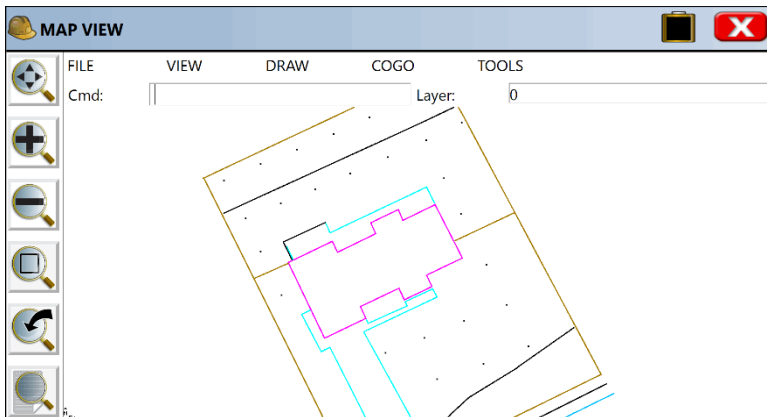

*Note: The above graphic display is default. In the Map screen, the normal display includes pull - down menus. These can be disabled by selecting Preferences under the File menu, which expands the map area. The Preferences screen below shows the display options. The pull-down menu format is recommended.*

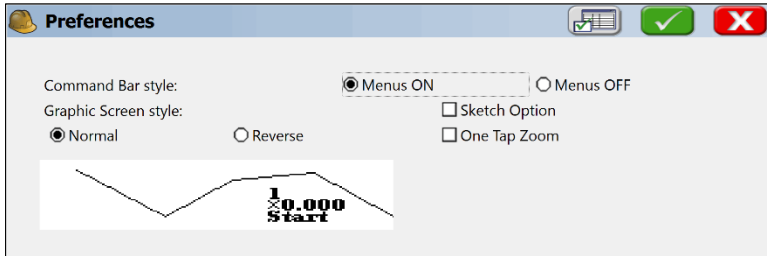

- **Recall World Image (Image Database):** Similar to the DXF file used for new jobs, this option would recall and place an image database background screen, such as an aerial photo, on each new job or existing job. Whatever image is actively displayed when the option is selected will be displayed when other jobs are loaded. If no image is active when the option is selected, then it has no effect. This would be useful for repeated new jobs where a particular aerial photo graphic is needed for reference. The actual graphic used is set within the Map screen, Tools menu, option Image Overlays, Use Image Database.
- **Allow Import .dxf/.dwg/Esri Options:** This creates additional options within the Map Screen, Import of .dxf and .dwg files. If .dwg files are created by the ArcMap command "Export to CAD", these files can be imported with attribute data using Import .dwg, if this option is turned on. For both .dxf and .dwg files, AutoCAD point entities can be detected and imported as point entities, and even stored to SurvPC point IDs as an option. New since SurvPC 3.0, blocks and inserts can be imported from .dxf and .dwg files, allowing accurate surveying and stakeout using the "center" point snap. SurvPC 4.0 and higher allows the importing of Text. Be aware that all of these special Import options can add dramatically to the drawing size if activated. The dialog below does not appear unless this Job Settings option is clicked on, and only lines and polylines will import in that case.

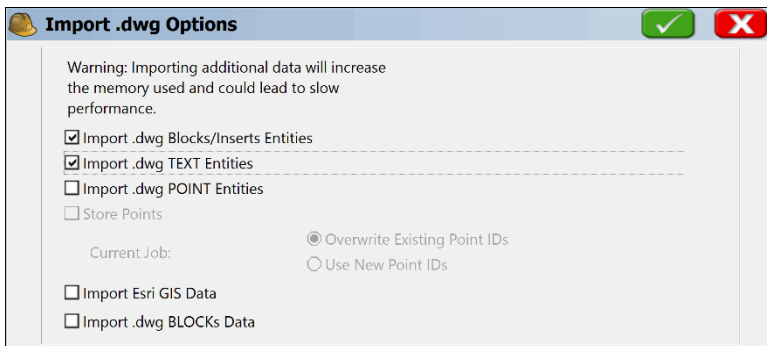

- **Default Cutsheets to EXCEL (\*.csv) Files:** Stores Cutsheets in \*.csv (EXCEL) format.
- **Use Finnish NLS Store Points Style:** Applies specifically to file formats used in Finland.



- **Use SWC Store Points Style:** This special style, although designed for particular companies, may have some general application. This option is designed for numeric field codes (eg, 10, 11, 101, 102, etc.). Although the screen appearance of the points is not altered, with this option clicked on, two preset GIS attributes are established.

**Code List: demo**

Category:  Set

Code	Linework	Line Type	Layer Name	Full Text	Code
2D	No	2D	TREE-SML	2"	2D
2P	No	2D	PINE-SML	2" PINE	2P
4D	No	2D	TREE-SML	4"	4D
4P	No	2D	PINE-SML	4" PINE	4P
6D	No	2D	TREE-SML	6"	6D

Add Edit Remove  
Load Save As Special Codes

**SWC Feature**

SWLS

Attribute	Type	Req.	Editable	Select-Only
PTNOTES	Char	No	Allow	No
PTCLASS	Char	No	Allow	Yes

Point  Edit Up Down  
Remove Add Save

**Edit attribute**

Name:  Codes

Prompt:

Default Value:  Set Default

Type:  Req.:  Clear Default

Field Edit Mode:   Use List Only

List Values:

MEAS
CTRL
AVG
TPS

Add Remove Up Down



A special icon appears as shown above left within Feature Codes command, which when clicked, leads to the 2 preset attributes for each point. Preset as well, within PTCLASS, are 4 selectable class values (measured, control, average and TPS). All of these attributes can be edited or added to. The attribute prompting applies only to field-measured points, not points created in the Map Screen with the Create Points command. If "Time Stamp Each Point" is on within Job Settings (described above), then use of the "SWC Style" leads to a specially formatted point list when Export ASCII file is used.

There, the SWC option leads to the format below:

Pt ID, Northing, Easting, Elevation, Feature Code, Action Code, Description, Date, Time, HRMS, VRMS, PTCLASS, Measurement Code /Backsight Prism Offset/Foresight Prism Offset

The prism offsets in the ASCII Export file apply only to the "TPS" point class or total station measurements.

- **Allow Stake Nearest Pt from Points List:** Within Stake Points, points can be selected and added into a "stakeout list". With "Allow Stake Nearest.." on, as each point from the list is staked out, the nearest point to the last one staked will be selected next. This reduces the distance to move with each stakeout. However, by targeting the next nearest point, you may move in a direction where the last few to stake are behind you and relatively far away.
- **Skip Confirmation Screen in NEXT STK Pts:** Within Stake Points and other commands that allow "N for Next" (to move to Next point in order or to move to Next alignment point to stake), the screen confirming the point or station to stake is omitted for faster field stakeout.
- **Allow "Navigate to" in Store Points:** Selecting this option brings up two icons in the upper left of the Store Points screen, which allows Navigate to a picked point and Navigate along a path defined by a series of picked points. This enables simultaneous navigation and storing of points within the Store Points command. Shown below is use of the left-most icon (Navigate to Point) within Store Points. Note that an effective "View" Method within Configure is Deflection/Distance. A deflection left as shown would put you on line towards the selected point. When selecting a point to navigate to, by snapping, the ? snap allows you to pick a point in blank space, anywhere.

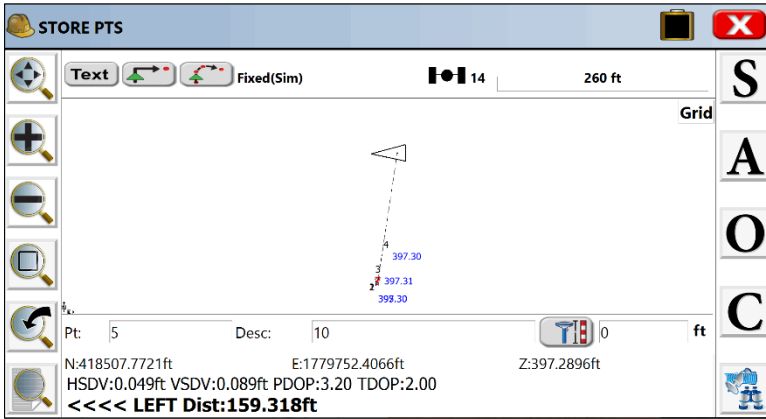

- **Show TEXT/VIEW Buttons:** When clicked on, Store Points will show a TEXT button in the upper left to allow clicking into the Text screen for storing (no graphics, just large print data) and Stakeout screens will offer the View button in the upper left leading to a special large text stakeout screen (shown below). Once in Text mode, the normal graphic screen mode can be selected using the Helmet options (icon in upper left) by selecting "Graph". Text mode itself can always be chosen using the Helmet in addition to the configurable "Text" button.

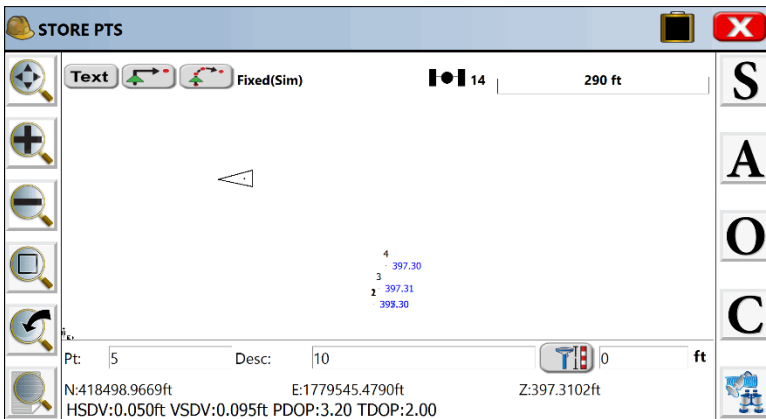

- **Auto-Fit Positions/Measurements displayed in the bottom bar:** With this option turned on, the number of decimals shown for either the Northing or Easting (depending which number is larger), or both, are reduced in order to fit the North, East and Elevation data on one line underneath the graphic display, within Store Points and the stakeout commands. In the example below, the Easting is reduced to 2 decimal places, from the standard 4 decimal places. With this option set to off, some clipping or overwriting of the numbers may occur as the program tries to display all data to 4 decimal places.



Pt: 3	Desc:		0
N:419101.2775 E:1779973.07> Z:397.3027			
HRMS:0.046 VRMS:0.077 PDOP:3.20 TDOP:2.			

- **Use smaller font to display Postions/Measurements in the bottom bar:** Instead of reducing the number of displayed decimal places to fit all N,E,Z data, the program reduces the font size to fit the data:

Pt: 3	Desc:		0
N:419744.7683 E:1780182.6358 Z:397.2955			
HRMS:0.047 VRMS:0.094 PDOP:3.20 TDOP:2.			

- **Apply "GNSS Analysis" to Average GPS Points with Identical IDs:** Within the command Point Average in the Cogo (coordinate geometry) menu, this option introduces a distinct averaging method for GPS measurements that applies a Chi Square analysis using vector data to the identical points, as read from the raw file, and includes blunder detection and blunder point removal. Points collected individually within Store Points, or by A for average within Store Points, sharing the same point ID, will be averaged by statistical methods including estimates of accuracy, which under most conditions of measurement will exceed normal RTK accuracy. This option can be viewed as a form of post-processing in the field, leading to greater accuracies. Be sure that "Store Vectors in Raw Data" is turned on (above, in Job Settings). Your GNSS equipment needs to have the vector storage option available. Furthermore, it is advisable to turn on, within the Hgt/Description prompt, "Avg Same Pt ID". Once this is clicked on, the Hgt/Description prompt itself can be turned off (to reduce prompts in the field) using the Configure command (C for Config or Equip-Config).
- **Auto Store Pick Points:** With this option turned off, when you select line or polyline endpoints when defining alignments using the Map button selection (highlighted below), no new point IDs are created. Selections are referred to as "picked point 1" (PP,1) and "picked point 2" (PP,2) temporarily and then discarded.





**Define Line** [✓] [X]

First Point ID: (from Current Job)  [Menu] [Snap]

Second Point ID: (from Current Job)  [Menu] [Snap]

North Azimuth:  °

Slope:

Method:  2 Point  Azimuth

Start Sta:

End:

Similarly, with Auto Store Pick Points off, no new points are created in the screen view or in the file when selecting line elements for stakeout.

**STK LINE** [Map] [X]

Turn to AR: 315°00'00"  [R]

[S] [N] [M] [El]

Pt:  Desc:   ft

AR: ... ZA: ... SD: ...

**Dsg:0+00.000 Z:100.000ft L0.000ft**  
**Turn to AR: 315°00'00"**  
**Move Out 500.000ft**

But with this option on, new points are associated with the screen-selected alignment when picked using the "from Map" snaps. Note that the "down - arrow" option was used to expand the graphic screen viewing area. The "angle right" instructions are still seen at the top of the screen.

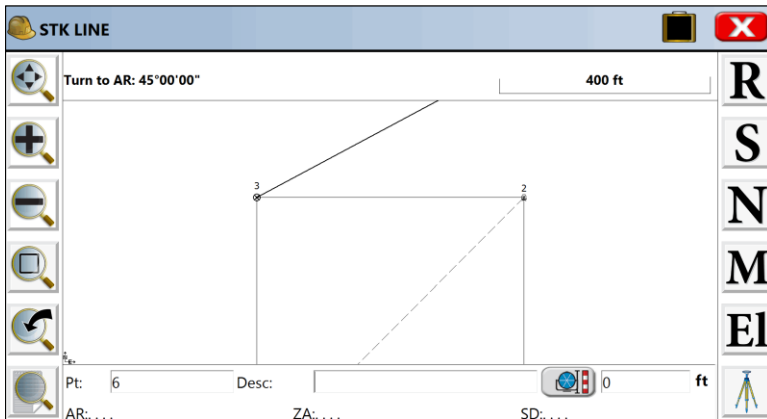

- **Store Rod Height as Notes:** With this option on, the Rod Height is stored in the note file associated with the job in addition to being stored in the RW5 file.
- **Show Code List when DESC Used:** This very useful setting allows faster field operation by eliminating the need for Prompt for Height/Description on (in Equip, Config, or set by C button for Configuration). The Height/Description prompts is preferred by many surveyors to double-check the rod height and to pick the default feature code and same-day used descriptions from a list. But this involves an extra screen to appear. If you turn off Prompt for Height/Description, you can save a screen, and with "Show Code List when DESC used" On, you can get the description field in the single point measurement screen. For example, with this option off, a description would need to be entered (see graphic above). But with this option on, you get a "From List" icon and can select the desired description with a single pick (see below). This appears not only in Store Points but in Stake Points (when storing points) and in any command where points are stored.
- **Include Pt Blocks in the current DXF on Save:** It is recommended to keep this option clicked off, unless you want to DXFIN the point blocks themselves into an external CAD program. This feature, new with SurvPC 4.0, can drastically reduce the time to save and load jobs. If a job has 2000 points, not only the linework and blocks (symbols) on the screen are saved to the DXF file, but also the point graphics can be saved to the DXF file, making it larger and slower. But since the point graphics, in effect, duplicate the points themselves in the CRD file, they are redundant and typically unnecessary to be saved in the DXF drawing when using SurvPC. So, click this option OFF to speed up saving and recalling jobs, since the points will load quickly and display on their own directly from the CRD file itself.



- **Allow GIS Data Prompting for STK Points:** With this option clicked on, you get an extra prompt when staking out to select GIS attributes to associate with the staked points. Then whatever the GIS prompts are for the feature code, they follow on the next screen(s). Here is how this appears:

### Stakeout Report

Staked:	300090.526	Easting(ft)	1377870.955	Elevation(ft)	397.312
Design:	5575.000		6575.000		125.000

Move: South:294515.526ft West:1371295.955ft Cut 272.312ft

VOff 1:  ft Elev:  ft

VOff 2:  ft Elev:  ft

HRMS:0.050ft VRMS:0.074ft PDOP:3.200

Store Point Point ID:

Set GIS

### Description

Desc:

- CB1
- CB2
- CB3
- CB4



## 4.6 Job Settings (Stake)



This tab allows you to set configuration options for the stakeout routines.

The screenshot shows the 'Job Settings' dialog box with the 'Stake' tab selected. The 'Precision' field is set to 0.000. The 'Store Data to Note File' checkbox is unchecked. The 'Merge Ctrl File Pts for Stk' checkbox is unchecked. The 'Control Pts Have Priority' checkbox is unchecked. The 'Use Automatic Desc' checkbox is checked. The 'Increment Pt ID' radio buttons are set to 'Up'. The 'Stake Offset Desc' button is visible. The 'Alignment Settings' button is visible. The 'Auto Descriptions' button is visible. The 'Cutsheets' button is visible.

- **Precision:** Use this to control the decimal precision reported during stakeout routines.
- **Store Data to Note File:** This option specifies whether or not to store the stakeout data in the note file (.NOT) for the current job. At the end of staking out a point, there is an option to store the staked coordinates in the current job. Note (.NOT) files are associated with points, so you must store the point to also store the cutsheet note. This additional data includes the target coordinates for reference. Keep in mind that the cut and fill data is also stored in the raw file. You can also store an ASCII cutsheet file using the button at the bottom of the dialog, so storing into the note file is somewhat redundant. SurvPC does not show the cutsheet note within List Points (notes turned on), since this feature only shows notes that begin with "Note:." The one advantage of the note file is that notes are viewable in association with points using Carlson Software office products such as Carlson Survey. See command Cutsheet Report, option Note File.
- **Control File Points have Priority for Stakeout:** This option, which applies to both total stations and GPS, will give priority to the control file point during stakeout, when the point requested exists in both the current file and the control file.

*Note: Use this option with care. You may not realize that this option is set, and will discover that directions to your expected stakeout point of 10 are really based on a point 10 from another file altogether – the control file.*

- **Use Automatic Descriptions:** This allows you to have descriptions automatically entered for staked locations based on the settings defined by the Auto Descriptions dialog.



- **Increment ID UP/Increment ID Down:** Within the Stake Points command, you may need to stake points in decreasing order (see below). In this case, you can preset to Increment ID Down, so prompting would be 87, then 86, then 85, etc.

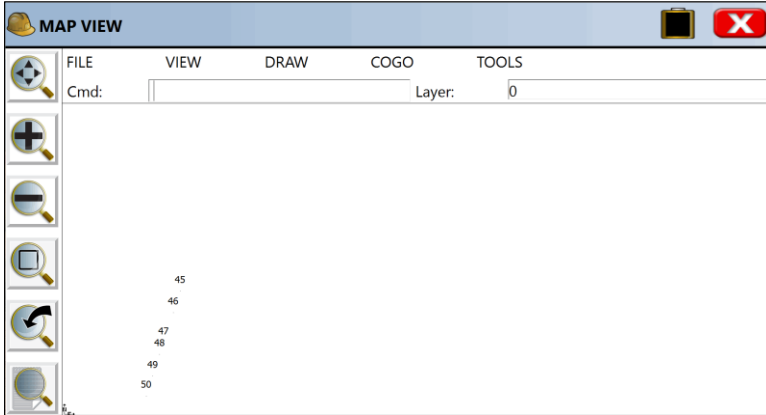

### Stake Offset Description

This allows you to define what the ID is called for each offset location in the Stake Offset routine (Surv Menu).

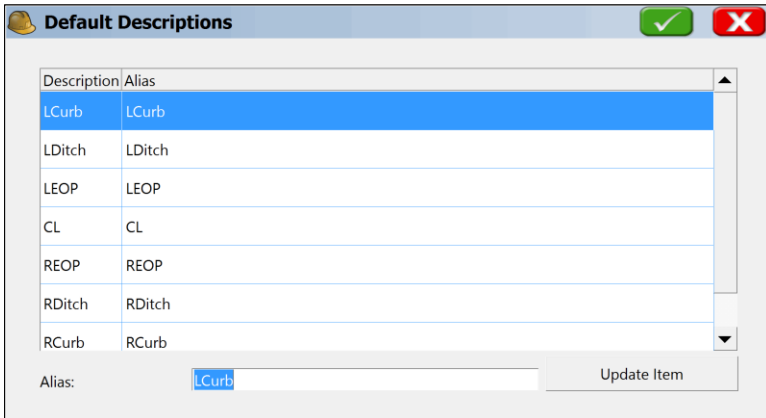



## Auto Descriptions

This button allows you to configure the point description when you store points in stakeout. The very act of storing a staked point is optional. You can stake a point or a station and offset but must click Store Point within the stakeout screens to actually store a point. If you do choose to store the point, the description is configurable. See image below.

Item	On/Off	Prefix
Stake Pt ID	ON	STK
Station	ON	STA
Stake Desc	ON	
Offset Left	ON	L

Off All    On All    Move Down    Move Up

Prefix:   On/Off    Update Item

STK1317 CB#22 CUT 2.1ft  
STA1+00.000ft CL L10ft CUT 2.1ft

A user in Australia or Great Britain might want to change the STA for “Station” to CH for “Chainage”. An example of a typical stake description, based on your configuration settings, is shown at the bottom left of the screen. The first line (STK1317 CB#22 CUT 2.100) represents a typical Stake Point description, where CB#22 is the description you would enter, and the rest is governed by your Stake Description settings. Similarly, if centerline-based stakeout is being conducted, then the lower line would apply. The description (CL in this case) is the only aspect entered by the user in the field during stakeout. All the rest is reported based on your Stake Description settings. If you turn off an item, note how it will not appear in the reported “sample” description. The “+” in the station can also be configured to appear or not appear, but this is set globally within the Format Tab of Job Settings. The behavior of the On/Off, Up/Down and Update buttons is identical to that discussed in the Cutsheet section.

Other routines, particularly Cross - section Survey and Slope Staking (part of the Roding features), have their own settings for descriptions. When any automatic description for stakeout is turned on, the program will no longer default to the last-entered description such as "EP"; it will use the “automatic” description instead. If you type a new description, you will turn off the “automatic” stakeout description. If you delete the default (new) description, the program will return to using the automatic stakeout description. To delete, you can simply place the cursor in the description field and hit the delete key — there is no need to first highlight the description.



## Alignment Settings

This dialog allows the user to define how all alignments and roads are staked.

### *Alignment Tab (Applies to N for Next Station and all auto-incrementing of stations)*

- **Increment from Starting Station:** For centerlines that start on an “odd” station such as 1020 (10+20 in U.S. stationing format), this option would conduct stakeout by interval measured from station 1020. So, a 50 interval stakeout, instead of being 1050, 1100, 1150 would be 1020, 1070, 1120, etc.
- **Extend Alignments:** This will project a tangent line off of the first and last segments of the alignment for extending them beyond their defined limits.
- **Stake Start and End Stations:** This instructs the software to start and increment to these critical locations even when they do not fall on the even station.
- **Stake CL Alignment Points:** This instructs the software to stop at these critical locations (e.g. PC, PT, curve-to-spiral, etc.) even when they do not fall on the even station.
- **Stake Profile Points:** This instructs the software to stop at these critical locations (e.g. PVC, PVT) even when they do not fall on the even station.
- **Stake High and Low Points:** This instructs the software to increment to these critical locations even when they do not fall on the even station.
- **Template Series Station:** If a Template Series File (\*.tsf) file is used, which is a series of templates applied to ranges of stations and transitioning between templates, then all stations entered in the \*.tsf file for starting and ending a particular template will appear in the incrementing list of stations.
- **Combine Station Equations:** This allows the user to overlap the station equations.
- **Apply Station Equations:** If turned off, this allows the user to ignore the station equations so that the station reflects the length of the alignment.
- **Offset Gap Type: Fillet:** This allows the user to define the offset gap type used when defining offsets within Stakeout Line/Arc routine at straight corners as: radius fillet or radius zero fillet. If turned off, the offset to the outside has fillet



radius=0 and comes to a point. If turned on, the radius equals the offset and the outer intersecting offset contains an arc with radius equal to the offset.

- **Allow Reference Centerline:** With this option clicked On, a "Reference Centerline" (sometimes called "Master Centerline") icon appears in Stake Line/Arc and other alignment-based roading routines. This allows stakeout to a target alignment referencing a "master centerline" for forward-back instructions, and for reporting.
- **Remove Sta Eq when Loading SCT File:** Special feature to remove reference to station equations on loaded cross - sections. Applies to Input-Edit Section File and Section File Conversion, within Road Menu, Utilities. For example, if you had 4 stations, 0+00, 0+50, 1+00 and 1+50, but had a station equation where 0+75 forward = 0+50 back, the equation is removed, and the 4 stations become 0+00, 0+50, 1+25 and 1+75.
- **Remove Sta Eq when Loading PRO File:** Special feature to remove reference to station equations on loaded profiles.
- **Limit Station Range:** When selected, the program will not automatically advance beyond the natural start and end of a given centerline.
- **Use Station and Offset List:** Use this option to load a predefined list of stations and offsets. This allows the Stake Offset routine to use a pre-defined list of station, offset, and elevation information as defined by the user. This is sometimes referred to as "Cutsheet" list. An ASCII file with a .CUT file extension is required. The file format is shown below:

*Station, Offset, Elevation, Description, as in  
20100, -11.5, 102.34,  
20109.23, -11.5, 102.35, PC*

**Settings**

Alignment **Road**

Next button advances to: Next Station

Next Button Auto Advance

Stake Section File Stations

Always Zoom All

Hold Offset

Hold Grade ID

Sections Include Catch Points

Use Railroad Definition for Curves

Zoom In/Out: 10 %

Vertical Scale: 5.00

Degr. of Curvature: 100 ft

Display Slope As Ratio





## **Road Tab**

- **Next icon advances to:** This defines how the "Next" icon will behave. It can advance to the next station or the next offset location.
- **Stake Section File Stations:** When ".sct" cross - section files are involved, this instructs the software to stop at the stations within the ".sct" file along the alignment even when they do not fall on the even station, or other selected alignment station. If you had a cross - section at station 178, the program would stake station 178 and increment to it even if that station was not a "critical" station, not a start, end, PC or other special station.
- **Sections Include Catch Points:** This instructs the software whether or not the design sections were extracted/stored to the shoulder/back-of-ditch point or all the way to the design catch location. If the design catch location is included in the section, the software will automatically determine the pivot point at the next interior section point for slope staking purposes. The design slope ratio will be determined by the last two points in the section. This applies within the command Road Menu, Stake Slope, Section File option.
- **Always Zoom All:** This zooms the preview window automatically to fit the extents of the current section.
- **Hold Offset/Hold Grade ID:** If Hold Offset is selected, the zoom holds the actual numerical offset of 12, for example, for a 12' roadway width but if Grade ID is selected, the zoom holds the calculated position of the Grade ID and factors in widening of the lane. This applies to cross - section viewing within Stake Road.
- **Zoom In/Out:** This determines the zoom increment of the preview window.
- **Vertical Scale:** This allows the user to exaggerate the scale vertically.
- **Display Slope as Ratio:** Instructs the program to display ratio instead of slopes-- useful for cut and fill slope display.
- **Degree of Curvature:** This allows the user to define the degree of curve base value when metric: 100 ft is the default value used for US Feet or US International Feet.
- **Use Railroad Type Curves:** This allows the user to define the use of railroad definition for the curves present within the alignment used inside the Stakeout Line/Arc routine.



## Cutsheets

There can be as many as five cutsheet files active at one time, one for point staking cutsheets, one for centerline staking cutsheets, one for slope stake cutsheets, one for "grade stake" style cutsheets and finally one for the "story stake" cutsheets. The latter two (grade stake and story stake) cutsheets are described in some detail within the Stake Road command. All cutsheet files can be given distinct names, and any of them can be turned on or off for purposes of storing. And finally, if cutsheets are reported from the raw file, a distinct new name can be assigned prior to recalling the raw file and creating the cutsheet file. All cutsheet files are ASCII and can be viewed in a text editor or an Excel Spreadsheet.

The Cutsheets button leads to the following options:

Stake Type	Checkbox	Select File	Current File	Format	Edit File
Point Stakes	<input type="checkbox"/>	Select File	None	Format	Edit File
Alignment Stakes	<input type="checkbox"/>	Select File	None	Format	Edit File
Slope Stakes	<input type="checkbox"/>	Select File	None	Format	Edit File
Grade Stakes	<input type="checkbox"/>	Select File	None	Format	Edit File
Story Stakes	<input type="checkbox"/>	Select File	None	Format	Edit File

- **Point Stakes:** Toggling this option on enables writing to the selected cutsheet file. The buttons allow the user to select the file, customize the Point Cutsheet report format as well as edit and view the current point cutsheet file. This applies to the command Stake Points.
- **Alignment Stakes:** Toggling this option on enables writing to the selected cutsheet file. The buttons allow the user to select the file, customize the Alignment Cutsheet report format, and edit and view the current alignment cutsheet file. This applies to commands within Stake Line/Arc, and to Offset Stakeout, Point Projection and Stake Road (in Roding) and includes station and offset options in the stored file, as well as cut/fill. A special "centerline-style" cutsheet file, containing station and offset information, can be named and saved within the Roding command, Cross - section Survey. This file is viewable in the editor within Set CI Cutsheet Format, but has no cut/fill values, just "as-built" data. Centerline-based cutsheets have more configurable options in the report, such as Stake Station, Staked Offset, Design Station and Design Offset. The Design Point ID is one of the configurable items to report, and since commands such as Offset Stakeout, Point Projection and Stake Road do not stake out Point IDs, the program uses either the command name (CL for Stake Centerline, PP for Point Projection), offset reference, or template ID as the "design point name". "RCurb", for example, would be the name given to the design



point in Offset Stakeout for top of curb, right side. This might lead to a variety of ID names for the design point.

- **Slope Stakes:** Toggling on enables writing to the selected cutsheet file. The buttons allow the user to select the file, customize the Slope Stake Cutsheet report format as well as edit and view the current slope stake cutsheet file. This applies only to the commands Stake Slope and Stake Road available within Rooding. Slope Stake Cutsheets have an extra option to “Include progressive offsets report”, and also have different options such as “Pivot Offset”, “Slope Ratio” and “Elevation: PP/CP” (Elevation of Pivot Point and/or Offset Point). Note that columns can serve a dual purpose in the slope stake report. If progressive offsets are enabled, the header lines (such as Design Station) are ignored for the additional information, and you obtain the incremental, delta distance and elevation from each point on the section or template from the offset stake to the catch and then all the way into centerline. These last three options allow you to customize the respective output report. To change an item label, highlight the item, change the Header Label field, then tap Update Item. You can select an item in the list and turn it ON or OFF (no reporting). You can also control the order of the report items by using the Move Down and Move Up buttons. Changes must be made prior to starting a new cutsheet file.
- **Grade Stakes:** With this option on, even the Grade Stake method used for stakeout, within Stake Road, will output a specific format.
- **Story Stakes:** Will output a "story stake" cutsheet if "Story Stake" is clicked within the Stake Road command. Cutsheets for both grade stakes and story stakes (all points in the cross - section) are discussed in the Stake Road portion of the manual.
- **Select File:** Tap this button to select the output file. The file name is shown below this button.

### Format

Select the format button to configure each cutsheet to your liking. Column order and column headers are completely user-defined and any column can be turned off if not useful.

Item	On/Off	Header Label
Design Pt#	ON	Design Pt ID
Design Nor	ON	Design North
Design Eas	ON	Design East
Stake Nor	ON	Stake North
Stake Eas	ON	Stake East

Header Label:  Update Item

Cutsheet from Raw  On/Off

Down Up



- **Header Label:** You can substitute header text of your own choice for the defaults. Here, the text Pt ID was substituted for Design Pt#. Tap Update Item after changing a Header Label. These changes should be done prior to starting a new cutsheet file—they cannot be applied retroactively to a file that already contains information. However, the header line in that file (e.g. Market.txt) can always be edited using Notepad or any text editor to accomplish the change.
- **Down-Up:** Items in the list can be moved up and down to change their order. For example, if you prefer Fill *before* Cut in the report, just move Cut down below Fill.
- **Cutsheet from Raw:** SurvPC automatically stores cutsheet data and header information to the raw file for the job. You can capture and report the cutsheet information directly from the raw file. Before doing this, it is recommended that you start a new cutsheet file, configure the header lines, and order of information as desired, then run “Cutsheet from Raw”. This option is very useful if no cutsheet file was established in advance of field work. This enables a cut and fill report by reading the raw file directly.

### ***Edit File***

Select this option to edit and review the cutsheet file. Shown below is an alignment cutsheet file as viewed in the Edit File option. Notice that the vertical bars of the spreadsheet can be moved left and right to condense the display. Just pick them in the title line and move them. The Cutsheet editor also includes the ability to insert and delete lines. If you insert a line and enter a Design Elevation and a Stake Elevation, the program will compute the cut or fill. Using the Special button, you can increase or decrease the Pt ID, Design Elevation or Stake Elevation by any desired amount, and the cut or fill will be computed. Do not use the Special button to directly modify the cut or fill. If a second vertical offset is entered during stakeout, then two cut and fill results will appear for each point (useful, for example, for top and bottom of curb).

Design Pt ID	Design North(ft)	Design East(ft)	Stake North(ft)	Stake E
1	5000	5000	100	100
2	5001	5002	101	101
3	5002	5003	102	102

Insert   Up   Down   Delete   Special



## Settings Button



Select this for additional format controls for the cut and fill report.

**Cutsheet Settings**

Stored Story Stake Report

Slope Stake:  Progressive  Total  Combo

Stake Road:  Progressive  Total

Store Grade ID Only  Add Off Value

Show Report Up to CENTER

Include Slope Stake Report as Notes

Offset Prefix: Left:  Right:

For the "Story Stake Report", which is a report of all cut/fill and distance information to each break point on the target cross - section, options for the slope stake report within Stake Road include "Progressive" or individual distance between break points, Total distance from the staked point to each break point and Combo. The "Combo" option shows a "progressive", incremental slope ratio for each segment (last column), combined with a total HDist and VDist measurement to each point. For the Slope Stake Option, if "Total" or "Combo" are selected, the total distance reported can be from the Catch Point or from the Offset to the Catch Point. The normal Stake Road command also offers "Progressive" and "Total" options for the story stake report. Store Grade ID Only avoids storing a Point ID with each point. If you click on "Show Report Up to CENTER", you only get the cutsheet report for the Slope Stake and Story Stake break points on the same side of the alignment of your measured point. If this is turned off, you get a full report on both sides of the alignment. The Slope Stake Report can also be stored in the ".not" file associated with the job. The prefix for Left and Right of centerline is defined at the bottom of the dialog. "R" for Right would save space versus "Right", which was used in the example cutsheet file above. Various uses of these settings are explored within the examples found in Stake Road in the Road Menu portion of the manual.



## 4.7 Points



This command will list all of the points in the current coordinate (.crd) file. You can also edit any point in the list. If a Control File is active within Job Settings, Options, then you can also list and edit the Control File. The "From List" icon also allows you to recall points from both the current Job and the Control File job, if active.

Point ID	Northing(ft)	Easting(ft)	Elevation(ft)	Description	Point ID
8	418360.34	1779731.77	397.306		8
9	418409.07	1779747.64	397.301		9
45	418555.24	1779795.24	397.304		45
46	418533.39	1779788.13	397.296		46
47	418503.15	1779778.28	397.283		47
48	418491.39	1779774.45	397.314		48
49	418469.55	1779767.33	397.292		49
50	418449.39	1779760.77	397.305		50

The above figure shows the Points dialog. The point list includes Point ID, Northing, Easting, Elevation, and Description. Columns can be shifted to condense the display, as desired. The new positions, however, are not stored.

-  **Details:** The type of file (alphanumeric or numeric point IDs), number of points, unused points and highest point number in the file appear in the Details option.

Current Job	
Coordinate File:	C:\Carlson Projects\Data\New Job_2.crd
Type CRD:	Alphanumeric
Point ID Report:	
Highest Point ID:	50
Used Points:	
IDs:	1-9,45-50
Number of used points:	15
Unused Points:	
IDs:	10-44
Number of unused points:	35



-  Settings: Select the Settings button to customize the List Points display. The next figure shows the Settings dialog for List Points.

Field Name	Display Name
Point ID	Point ID
Northing	Northing
Easting	Easting

Show Point Notes

Add to Next Pt ID:   Use Highest Pt ID

Display Name:  Elev Digits:  Nor/Eas Digits:

**Show Point Notes:** Notes can be placed in any order on the list, or can be disabled, as shown above. (Only notes entered in response to “Prompt for Point Notes” or “Edit Notes” within List Points itself will display. Notes for GPS accuracy, time stamps and cutsheets, for example, appear in the raw file but not within List Points.)

**Add to Next Pt ID:** This makes it possible to number sequentially using 1 or add 2 to every point to skip every other number.

**Use Highest Pt ID:** This defaults the next available point to the Highest Pt ID in the file after starting SurvPC.

**Move Up/Down:** To rearrange the order of the fields, highlight a field and use the **Move Down** and **Move Up** buttons.

**Display Name:** To rename a field, highlight it, enter a new name in the **Display Name** field and then tap **Update Item**. This feature allows customization so that, for instance, Northing and Easting could become X and Y as renamed.

**Precision (Elevation Digits - North & East Digits):** The decimal precision for each field can also be set in the **Options** dialog.

- **Edit:** To edit a point in the list, double tap on it or highlight the point and tap the Edit button. You may edit any aspect of the point. To edit, move the cursor into the field of the aspect to modify and enter the new value. Choose **OK** to enter the edited point into the coordinate file, or choose **Cancel** to negate your modifications. The Input/Edit Attributes button refers to GIS data attributes associated with a point. These GIS attributes will export in the form of shape files (Tools pull - down in the Map screen). These attribute features help link SurvPC to the ESRI world, just as the DXF output of linework links to the CAD world.



**Edit Point**

Point ID: 50

Northing: 418449.3881 ft

Easting: 1779760.7679 ft

Elevation: 397.3050 ft

Description: EP

Input/Edit Attributes      Edit Notes

*Note: If only the description value is edited, the raw data file will be updated without writing a store point record. If any other value that would change the point position is edited, the raw data file will record a store point record with the new position of the point.*

- **Add:** To add a point, press the **Add** button. The **Add Point** dialog appears and you must enter the point ID, northing and easting. A store point record will be written to the raw data file. Data entered using the Add button may be edited (N,E,U -or- Lat, Long).
- **Find:** To find a point ID, tap the **Find** button. You can search for a point by Point ID or description, but not both at the same time. When searching by description, any part of the description can be used to find the point and the search "gs\*" has the same effect as "gs" to find points beginning with gs. Both would find the description "gs Sta 1+00 L25".

**Find Point in List**

SEARCH based on:

Point ID:

Point Description:

- **Delete:** To delete a point, highlight a point ID and tap the **Delete** button. You will be asked to confirm this choice before the point is actually deleted. To delete a range of points, use Keyboard Input within the Cogo Menu, option "Utilities".
- **Control File:** When a control file is specified, List Points offers the option to select the control file and to list the control file points. This feature enables the **From List** option found throughout SurvPC to access Control Points. The number of points and highest point number in the control file will now appear in the **Details** option.

Pts:15 <= 50      Job      Control      [Map] [List] [Back]





## 4.8 Raw Data



Carlson SurvPC creates a raw file (.RW5) that contains various lines of survey data similar to a surveyors' field book. The data contained in the RW5 file will vary depending upon whether a total station, robotic total station, or GPS is used during the survey. The name of the RW5 file will default to the specified job name (jobname.RW5). This command enables viewing and editing of the raw survey data, as well as traverse closure and adjustment computations for the survey, for both total station and GPS raw data. If total station shots are involved, a graphical representation of the traverse can also be viewed using this command.

If the GPS receiver is logging raw data and tagging sites in the receiver's raw data file is supported, sites will automatically be tagged when they are stored in SurvPC.

### Total Station and GPS Use

Total station adjustments are conducted differently from GPS adjustments (**Process GPS**). If you wish to adjust your GPS first for control, and then calculate your total station traverse, first select **Process GPS**. Then use **Process No Adjust**, or **Compass**, as desired. If the rw5 file contains only total station data, Process GPS will be "ghosted" and will not function. If the rw5 contains only GPS data, then only Process GPS and Edit/Export RW5 options will be available. If both data types appear in the rw5 file, all options are available.

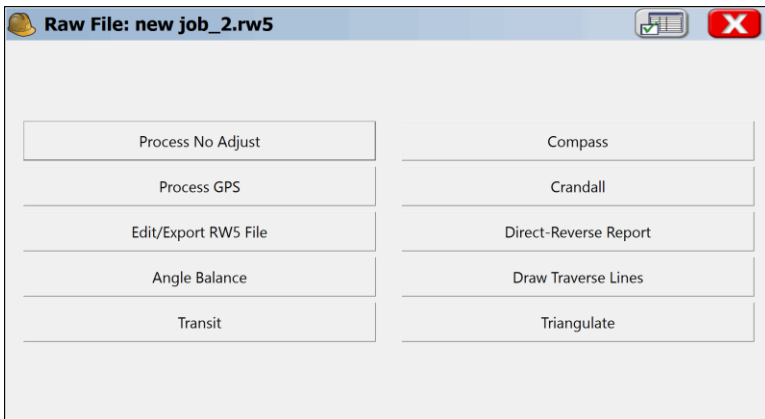

### Process Raw File Operations: Total Station, GPS, Reporting, Editing

SurvPC has made available four different types of raw file processing. You can process or draw your total station measurements, report out the Direct-Reverse measurements, Process GPS, and Review and Edit the RW5 file.

*Note that for all processing where new coordinates are calculated, beginning with SurvPC 2.0, upon exit the program will prompt you whether or not to store the newly calculated points into the coordinate file. This provides the flexibility to experiment with different processing settings and options without impacting the actual stored coordinates, until you deliberately choose to do so.*

### Total Station Adjustments



If you wish to adjust or draw a total station traverse, you would choose any of the following: **Process No Adjust, Angle Balance, Transit, Compass, Crandall** or **Draw Traverse Lines**. All of these commands have the same four-tab menu system, outlined below.

The screenshot shows the 'Process Raw File' dialog box with the 'Total Station' tab selected. The dialog has a title bar with a yellow icon, a green checkmark, and a red 'X'. The tabs are 'Total Station', 'Proj.', 'Redundancies', and 'Other'. The 'Total Station' tab contains the following options:

- Reduce to Grid Coordinates
- Scale:  ft
- Apply Curvature Refraction
- Starting Point:
- Ending Point:

- **Total Station Tab:** Reduce to Grid Coordinates will perform a “ground to grid” calculation based on your GPS projection used, viewable in the projection tab. The Scale Factor for each leg of the traverse and for each sideshot will be independently calculated by averaging the combined grid/elevation scale factor for the start and end of the measurement. Apply Curvature and Refraction will compute curvature and refraction distinctly on all raw measurements and adjust accordingly.

The screenshot shows the 'Process Raw File' dialog box with the 'Proj.' tab selected. The dialog has a title bar with a yellow icon, a green checkmark, and a red 'X'. The tabs are 'Total Station', 'Proj.', 'Redundancies', and 'Other'. The 'Proj.' tab contains the following options:

- Projection:
- Projection list defined in Job Settings under GPS



- **GPS Projection Tab:** This tab, critical for GPS calculation, only applies for total station work when **Reduce to Grid Coordinates** is set on within the Total Station Tab. To change the active projection, go to the GPS tab under Job Settings.

- **Redundancies Tab:** This screen covers the handling of multiple measurements to the same point, known as redundancies. There are three options for **Method**: Use First, Use Last or Average. For example, if you shot point 10 a total of four times, you could choose to use the first reading, the last reading or average them all. If you select Average, then the **Average Type** option becomes available. Here you can choose from coordinate or distance measurement. If you shot point 10 four times, twice from two different setups, and then chose **coordinate** under the **Average Options** drop-down, then the 4 northings and eastings computed would be averaged. If you chose instead **Distance Measurement**, then the two measurements would first be averaged, and then the two distinct coordinates calculated for point 10 (using the averaged measurements) would themselves be averaged.

The **Bacsight Reciprocal** option provides special treatment for reciprocals. A foresight to point 15 from a setup on 14, followed by a bacsight from 15 to 14, makes a pair of “reciprocal” readings. The bacsight reciprocal reading can be ignored (for its impact on recalculating the occupied point), or the Elevation component of the reciprocal measurements can be averaged, or both the Elevation and Distance can be averaged, to recalculate the setup (occupied point) coordinates. The program will calculate reciprocals for bacsight direct (BD) records. First set Bacsight Reciprocals to Average Elevation. Then if you foresight from 2 to 3, for example, then occupy 3 and bacsight 2, the stored BD record will lead to an averaged delta Z calculation for point 3 within Process No Adjust or any of the other adjustment options. If the Tolerances entered above are exceeded, then warning screens appear during the processing.

*Note: If there are significant redundancies in a traverse (reciprocal readings, D&R sets, multiple measurements to the same point from different setups, multiple tie shots into control) then it is recommended that the raw file be processed in a Network Least Squares program back at the office, such as SurvNet which is an add-on to Carlson Survey or Carlson Civil.*



**Process Raw File**

Total Station | Proj. | Redundancies | **Other**

Direct-Reverse Settings

Direct-Reverse Vertical Angles:  
Balance Direct-Reverse

Foresight-Backsight measurements:  
Balance Foresight-Backsight

Angle Tolerance (sec): 30.0"

Distance Tolerance: 0.2000 ft

- **Other Tab (for D&R Measurements):** This tab contains settings for how to use direct and reverse (D&R) measurements. For the vertical angles, you can balance the direct and reverse measurements or use **Direct-Only**. When you have Foresight measurements and Backsight measurements (e.g. slope distance/zenith angles) between the same points (e.g. reciprocals) in Direct and Reverse surveys, you can Balance Foresight-Backsight measurements (apply reciprocals) or use the Foresight data only. For purposes of warning screens, you can also set the Angle Tolerance and Distance Tolerance for Direct and Reverse measurement processing.

### Process No Adjust

This command processes the RW5 file and computes coordinate values for the surveyed data. No angle balance or traverse adjustment is applied. The **Process Raw Data Options** dialog shown below appears after selecting Process No Adjust and then the green check.

**Process Raw Data Options**

Report Sideshots

Report Closure

Reference Closing Point ID: 3

North: 5500.00000

East: 5000.00000

Elv: 100.00000

You can report the traverse only or compute all measurements by clicking on **Report Sideshots**. If you click on **Report Closure**, then you need to specify a **Reference Closing Point ID**, which is the point that the last traverse point is closing to, or trying to match. The **Reference Closing Point ID** is not a point in the traverse—it is the point the traverse is trying to close on. It can be entered as a point ID or a coordinate.



*Note: To preserve coordinate values of the initial setup and backsight, particularly with D&R measurements involved, it is recommended that Redundancies be set to Average by Distance Measurement, if averaging is used.*

Pressing OK leads to the calculation and the report screen for Process No Adjust.

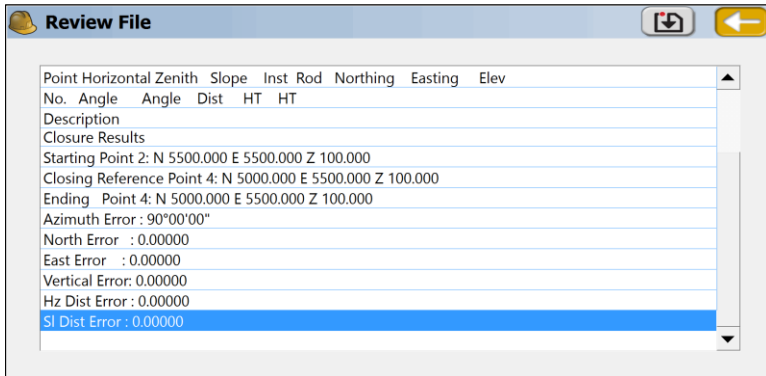

### Angle Balance

This method of processing applies an angle balance to the traverse lines when calculating the coordinates. The angle balance takes the angular error divided by the number of traverse lines and adjusts the angle of each traverse line by the calculated amount. The angular error is the difference between the angle balance shot and a reference angle. The program will prompt you to enter the traverse shot to use as the angle balance shot. The measured direction between the occupied point and the foresight point in the specified angle balance shot is then compared to a reference angle. The reference angle is specified as a bearing, azimuth or by a traverse line defined by entering a **From Point** and a **To Point**. The angle balance process is initiated by selecting the angle balance option from the process raw file menu.

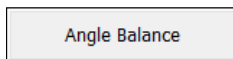

The Angle Balance Measurement dialog appears in the figure. Suppose a given traverse started at 24, traversed up to 25, then around a loop and back to 24 (point 45). If point 45 was the end point or closing shot, the traverse leg from 45 to 46 could be the angle balance shot. It is very common, for example, in closed-loop traversing to take a closing angle shot from the closing point (45) by measuring the angle along the first traverse leg (24 to 25). That is what occurred in the case of this sample traverse.



Occupy Pt.	Foresight Pt.
37	38
38	39
39	40
40	41
41	42
42	43
43	44
44	45
45	46

Next, the **Reference Closing Angle** dialog appears. Enter the bearing or azimuth of the reference angle or define the reference angle with points by entering in the desired point numbers in the **From Point** and **To Point** fields. If using bearing or azimuth, enter the bearing in DD.MMSS format and then select the correct quadrant from the format field located at the bottom of the dialog. Once the reference angle has been defined, then the angular error display will update with the calculated angular error. The measured closing bearing and measured closing azimuth is displayed at the top of the dialog box. If the reference angle has been defined by point numbers, then the reference closing angle field will update and display the defined angle. There is no need to select a format from the format field if point numbers are used.

Reference Closing Angle		OK	Cancel
Measured Closing Bearing:	N45°00'06"W		
Measured Closing Azimuth:	314°59'54"		
Angular Error:	-0.000600000		
From Point:	<input type="text" value="24"/>	To Point:	<input type="text" value="25"/>
Reference Closing Angle (dd.mmss):	<input type="text" value="45.0000"/>		
Format			
<input type="radio"/> NE <input type="radio"/> SE <input type="radio"/> SW <input checked="" type="radio"/> NW <input type="radio"/> AZ			

Pressing the **OK** button, or the enter key, will execute the angle balance process, and the process results will be displayed. The results display shows the closure results before angle balance and after angle balance.

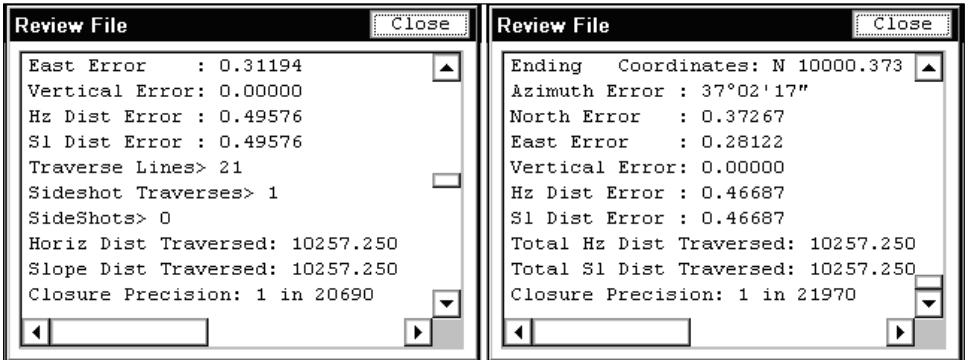

The angular adjustment applied to each traverse leg is also displayed, along with unadjusted angles and adjusted angles for each traverse leg. The adjusted coordinates are written to the coordinate file replacing the unadjusted coordinate values.

### Transit, Compass, Crandall Adjustments

These methods apply the selected rule to the traverse lines when calculating the coordinates. After adjusting the traverse points, the sideshots can also be recalculated. The closure error is calculated as the difference between the specified ending point and a reference point. The ending point is specified in the initial dialog.

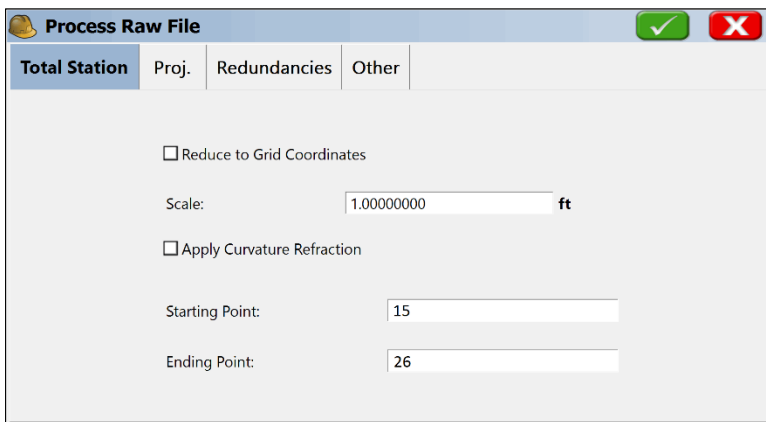

You can change the ending point to correspond to the point in the traverse that closes back to the existing reference point. In the current example, point 26 is the final shot, and is closing to an existing point, 10.

The reference point is specified by point ID or by entering the northing, easting and elevation of the reference point.

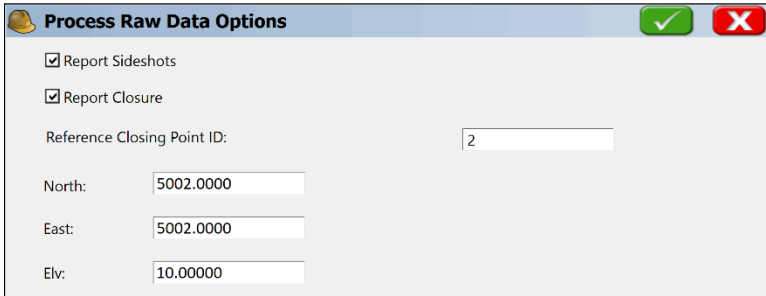

**Process Raw Data Options** [✓] [✗]

Report Sideshots

Report Closure

Reference Closing Point ID:

North:

East:

Elv:

The process results show varying information depending on selected options from the Process Raw Data Options dialog box.

- **Reference Closing Point ID:** The desired closing point number must be entered into this field. If the closing point does not exist in the coordinate file, the known coordinates can be entered into the North, East and Elevation fields on the dialog box.
- **Report Sideshots:** The report will include sideshots.
- **Report Closure:** The report will include a closure report

### Draw Traverse Lines

This button will process total station data and show the traverse and sideshots graphically. The example below shows 2 traverse legs and a total of 6 sideshots.

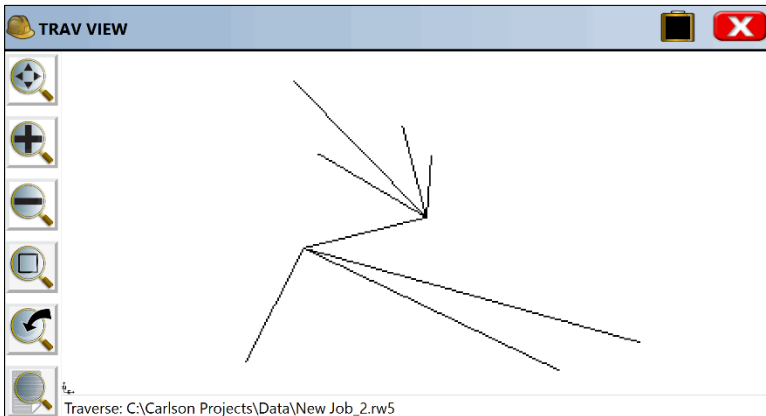





## Process GPS

This option is available when GPS data is detected. The opening screen appears below:

**Process Raw File** [Green Checkmark] [Red X]

**GPS** | Proj. | Redundancies | Types

Scale:

Localization File

Geoid Separation File

Localization File: None

Geoid File: None

Transformation:

Plane Similarity

One Point Localization Azimuth:

State Plane Grid

If a virtual reference station is used, then the Projection tab will govern and there will be no Localization File, which typically applies to a base-rover setup with UHF radio communication. Clicking the Projection Tab reveals the active projection. Similar to total station adjustment, the Redundancies tab allows selection of the First measurement, Last Measurement or Average of all measurements when duplicate ID measurements are detected. A set of GPS (Lat/Long) measurements can be recalculated based on new, distinct localization files. For example, if your very last measurement was a control point, you could add that to your localization file (Equip, Localization) and then go to Process GPS to recalculate all GPS measurement taken that day.



## 4.9 Feature Code List



This command allows you to define default, ready-to-use descriptions. These descriptions lead to linework drawn within SurvPC as well as point symbols. It is important to point out that the drawing of linework and point symbols must be "activated" within Job Settings, Options, by clicking on "Use Code Table for Descriptions". If this is clicked off, linework and symbols will not be drawn. SurvPC ships with "Use Code Table" on. In addition, within Configure, the option "Show Line Details" will automatically redraw the linework whenever any revision occurs or whenever the Map screen is selected. So, if you had a line drawn from points 101 to 105, but then you edited or resurveyed point 102, "Show Line Details" will lead to the automatic redrawing of the line whenever the graphics are shown. If this is clicked off, then you would need to go to the Map screen and select Tools, Field-to-Finish, to update linework.



The image shows two overlapping dialog boxes from a software application. The top dialog is titled "Job Settings" and has tabs for "New Job", "System", "Format", "Options", and "Stake". The "Options" tab is selected, showing a list of checkboxes. The "Use Code Table for Descriptions" option is highlighted in yellow. Below the list is a "Select File" button and a text field containing "C:\Carlson Projects\Data\NewJob2.crd". The bottom dialog is titled "Configure" and has tabs for "General" and "View". The "General" tab is selected, showing a list of checkboxes. The "Use Line Details" option is highlighted in yellow. Below the list are several input fields: "No. of Readings to Avg -" with a dropdown, "TS:" with a text field containing "1", "GPS:" with a text field containing "1", "Enter/Store Icon - TS:" with a dropdown containing "Read & Store", and "Enter/Store Icon - RTS/GPS:" with a dropdown containing "Read & Store".

**Job Settings**

New Job | System | Format | **Options** | Stake

Use Control File

Select File C:\Carlson Projects\Data\NewJob2.crd

Time Stamp Each Point

Store GPS Accuracy in Raw File

Store GPS Vectors in Raw File when available

**Use Code Table for Descriptions**

Recall Job Road Files

Auto Load Map

Auto Save Map

Recall World Image

**Configure**

General | View

Use Graphic Icons in Survey

Use Audible Alerts

New Job Use Alphanumeric Format

Use Point Symbols

**Use Line Details**

Use Layerized Points by Feature Code

Use Grid Box for Map Selection

No. of Readings to Avg - TS: 1 GPS: 1

Enter/Store Icon - TS: Read & Store

Enter/Store Icon - RTS/GPS: Read & Store

Both lines and points can have attributes describing aspects such as material type, quality, age and date installed. You can create multiple feature code lists and each list can contain an unlimited number of codes. Each feature code consists of a short code, a longer description, a polyline toggle, and a polyline type setting. Point-type features can have symbols. All features can have associated prompting for GIS attributes. Feature codes can be organized into categories, which is useful to sort through large code tables using shorter lists picked by category. The initial dialog is shown below.

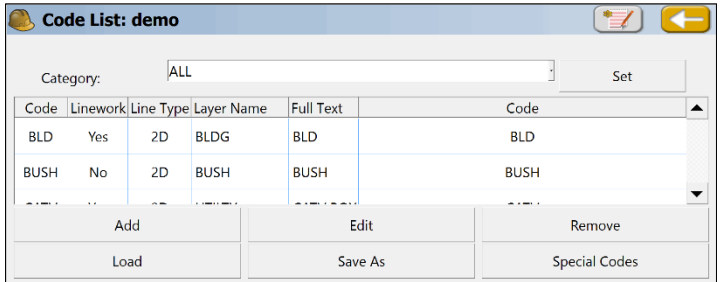

### Add a Feature Code Category

- **Set Button:** You can add a new category and then within Add or Edit Code, assign each code to a category. Clicking "Set" takes you to the Category Manager. Enter New Categories beside "New Name" and click New. This adds to the Category List within View Category. Then when selecting "All" categories, you can select one or more codes and assign them to the category selected at the bottom of the dialog, by clicking "Move To".

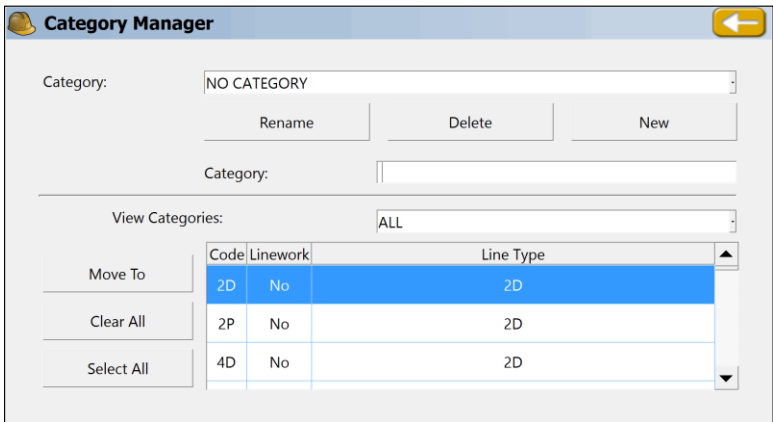

### Add a Feature Code

- **Add:** To add a code to the list, select this button. The **Add Code** dialog will appear.



### Select a Feature Code File

- **Load:** The **Load** button allows you to select a file to open or edit. Choose an existing file or enter a new file name to create a new Feature Code List. Feature Code List files have a \*.FCL file extension.

### Edit an Existing Code

- **Edit:** If you wish to edit an existing code, double tap on the code or highlight it and tap **Edit**. It will appear in the **Edit Code** dialog.

### Saving the Feature Code List

- **Save As:** Select the **Save As** button to save the file. Choose an existing file or enter a new file name to create a new feature code list.

### Remove an Existing Code

- **Remove:** To remove a code from the list, highlight an existing code and press the **Remove** button. SurvPC will ask you to confirm deletion of the code.

The **Add / Edit Code** dialog is shown below. Below the figure is a description list of the various options and buttons available in the dialog.

The screenshot shows the 'Edit Code' dialog box with the following fields and options:

- Code:** MH
- Category:** NO CATEGORY
- Set Symbol** button
- Name:** INLET\inlet10.bmp
- Layer:** UTILITY
- Select** button
- Color:** Blue color swatch
- Full Text:** Manhole
- Entity Type:** Point (selected), 2D Polyline, 3D Polyline
- New Feature** button
- Notes** button

**Code:** Enter the name of the Feature Code. For example, you might use EP for edge of pavement.

**Category:** If categories have been established (set) within the main Feature Code List screen, then individual codes can be assigned to a category. The very appearance of categories can be removed by clicking off the "Use Categories" option within Special Codes, Settings. This creates more space for the list of codes if there is no intention to use categories.

**Set Symbol:** For Point entity types, symbols can be assigned, as an option. Symbols plot on the screen for quick reference and will export by .Dwg or DXF using the Map Screen, provided "Include Symbols" is clicked on. Symbols are stored as bitmaps or ".bmp" files, along with ".dxf" files, on subdirectories of the "SurvStar\Symbols" directory created by the install of SurvPC and SurvPC. Three subdirectory "libraries" are typically provided: "Point", "Inlet" and "Trees" as shown below:

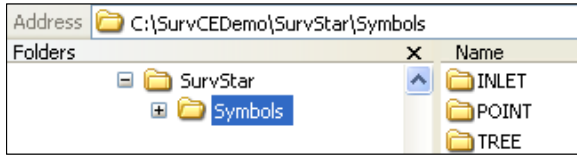

Within SurvPC, you can load the any symbol from any selected library by clicking the library, such as "Point" and selecting the symbol to use for the feature code.

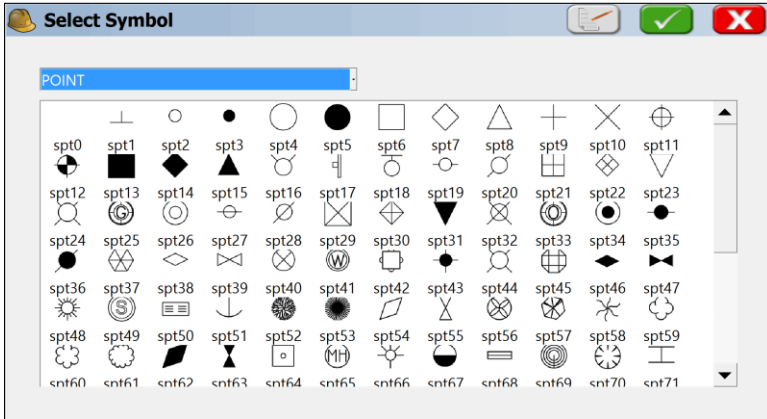

You can create your own symbol library, such as "DDC" shown below, by first creating the additional subdirectory within "Symbols" on your PC, then adding to that subdirectory both a unit-sized symbol and bitmap for display and viewing, for each symbol. If the "DDC" subdirectory is selected, for example, an additional manhole symbol could be added as shown below:

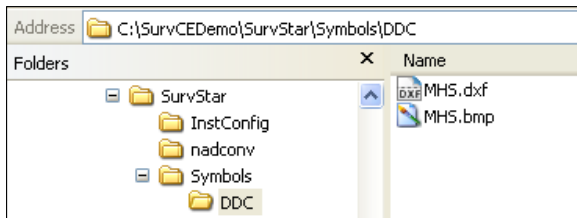



The bitmap for this "MHS" symbol appears as shown here:   
If MHS is entered as a new feature code, this symbol can be selected as follows:

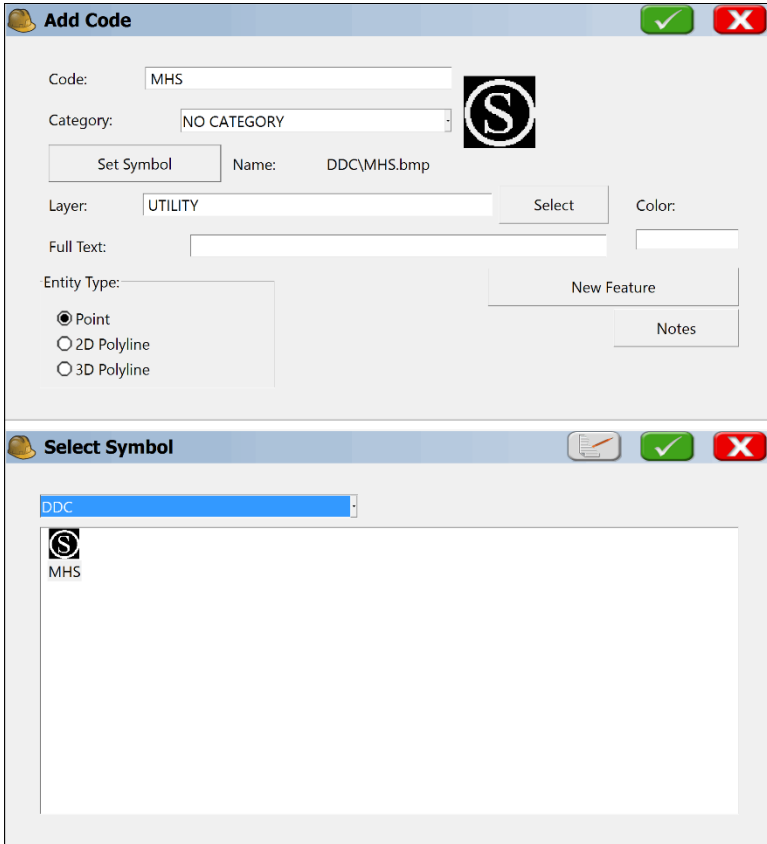



Then when locating MHS features in the field using the command Store Points, the newly defined symbol will plot, as shown below:

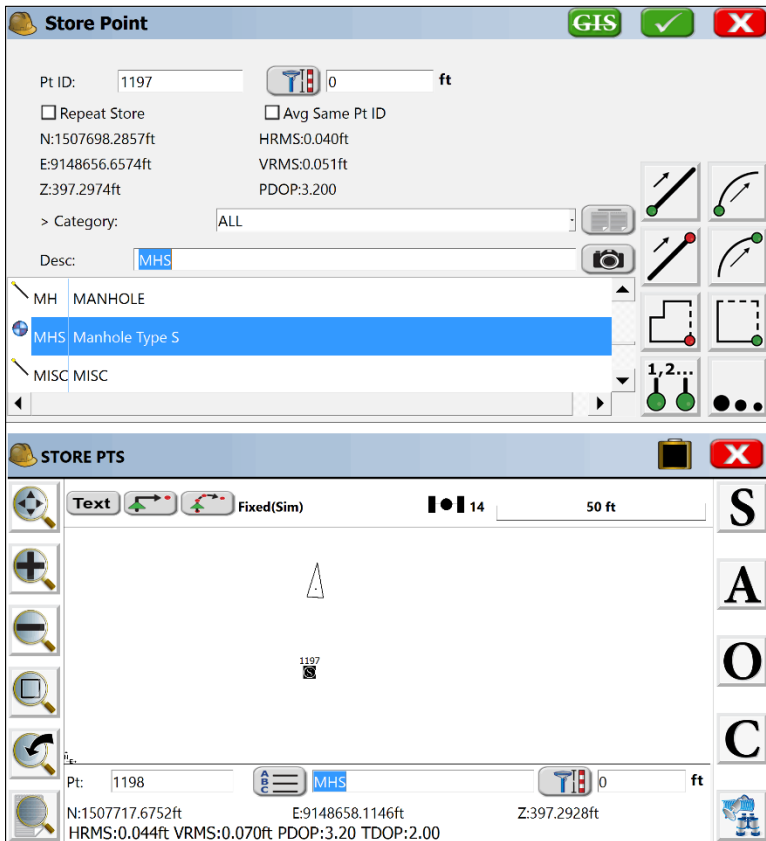

**Layer:** Symbols and linework can be assigned to layers, and will export to DXF or .Dwg files in the assigned layer. Even if office software is used to conduct field-to-finish, layers and distinct colors are useful for viewing points and linework while in the field.

**Color:** The color of the layer will be applied to the symbol or line. But if you click on the Color box, you can assign a different color than the one associated with the layer.

**Full Text:** Enter a description for the code. This is only for your information. It will not be added to the point description. It is particularly helpful when using numeric codes, to remind you of what they refer to.

**Entity Type:** There are 3 entity types: point, 2D polyline and 3D polyline.

**Polyline 2D vs 3D:** Choose whether the polyline should be 3D or 2D. If you choose **3D**, then each polyline vertex is located at the elevation of the point. If you choose **2D**, then the entire polyline is constructed on elevation 0, regardless of each point's elevation. If 2D is selected, you can change the width of the polyline (in inches or





centimeters if metric), as shown below. Selecting "Custom" allows entry of a user-defined width. An example of use might be a painted "stop line" at a road intersection.

*Notes: Allows the association of a user-entered Note with any feature code. Since notes have no character limit, large descriptions can be entered as notes and applied to each instance of the feature code, avoiding the need to enter or select the note in the field. Also, for options like "TR" for Tree, you can preset Notes such as the type of tree (oak, maple, etc.) and choose from a list of notes. "Prompt for Point Notes" should be turned on within Configure to access the Notes option. If Settings within "Special Codes" is selected, you can limit the list of notes to choose from, to just the list associated with the Feature Code, by clicking on "Use Code Notes Only When Storing Point".*

**New Feature (GIS Attributes):** This option leads to GIS type attributing, where you can further describe the code (e.g. MH for Manhole) with additional attributes. If GIS attributes are entered for a code, then the "New Feature" button becomes "Edit Feature". SurvPC allows use of the identical, "preferred" names for features as outlined in the ESRI Geodatabase Schema enabling direct uploading in ESRI products and Carlson office products, where the data is auto-linked to screen elements. The link to ESRI and the Carlson GIS office products is accomplished through the Shape File Export command in the Map screen. Then use Import Shapefiles in ESRI or Carlson GIS or other GIS products. An alternative is to save what is known as the MSC extension data into the .Dwg file within SurvPC, and then export to .DWG within the Map Screen. This imports seamlessly into ESRI products.

For example, consider a manhole survey where 4 distinct attributes are to be entered for each manhole surveyed: Lid Diameter, Wall Material, Depth to Flow Line, Number of Inlets. The setup process begins by clicking on "New Feature". If you click "Set", you see that the "Feature Class Name" for the code defaults to the code name "MH". The Feature Class is a GIS term which assists in the database linkages within GIS software such as ESRI and Carlson GIS. A typical "Feature Class" as named by the "Set" option, might be SWManhole representing "Storm Sewer Manhole". Do not use a colon (:), semicolon (;) or forward slash (/) in the Feature Class name. Clicking Set establishes the Feature Class, and the same Feature Class name can be assigned to



different codes. For example, Pine, Spruce and Deciduous trees can all be placed in Feature Class "Trees". In this case, you would enter SWManhole and click OK.

The image shows two overlapping windows from a software application. The top window is titled "Feature" and has a "In Use" checkbox checked. It contains a "Set" field with the value "MH" and a table with columns "Attribute", "Type", "Req.", "Editable", and "Select-Only". Below the table are buttons for "Point", "Edit", "Up", "Down", "Load", "Remove", "Add", and "Save". The bottom window is titled "Point Feature" and has a red "X" close button. It shows a smaller "Point Feature" dialog box with a green checkmark and a red "X" close button. The text "SWManhole" is entered in the attribute field. At the bottom of this window are buttons for "Select From List" and "Create New".

Then for this new Feature Class (SWManhole), you can enter the 4 attributes. The result is shown below at left, with a typical attribute entry (use Add to create new entry) shown at below right. If you click "Add" in the "New Attribute" screen (below right), you can create a list of values to select from while in the field. For an attribute such as depth (to flow line), a real number entry can be specified (as opposed to a character entry involving letters), and no default values would be entered since depths are variable. If you click "Use List Only", then you are restricted from entering an attribute in the field except what is in the list. If you click off "In Use" at the top of the Feature dialog, then you will not be prompted for attributes for this code when working in the field.



**Feature**  In Use ←

Set: SWManhole

Attribute	Type	Req.	Editable	Select-Only
COVERDIAM	Char	No	Allow	No
MATERIAL	Char	No	Allow	No
DEPTH	Real	No	Allow	No
INLETS	Char	No	Allow	No

Point:  Edit Up Down

Load Remove Add Save

---

**New attribute**

Name:  Codes

Prompt:

Default Value:  Set Default

Type:  Req.:  Clear Default

Field Edit Mode:   Use List Only

List Values:

1
2
3
4

Add  
Remove  
Up  
Down

When "MH" is coded in the field, the attribute options would then appear. If there are more than 3 options (as above), the Next and Previous buttons become active:

The same system applies to linework. For the fence line code "FL", an attribute called Fence Type might be used, and there may be 6 options, with a default option. These can be set up, one time, by using the **Add** option within New Attributes. Once setup, whenever a fence is chosen, the attributes can be selected from a list. These attributes will be stored in the raw file and most importantly, will output to an ESRI Shape file (Map Screen, File pull - down, Export SHP File). You can even control the prompt and what the default attribute is (in this example, "Chain Link") and if you wanted Chain Link to be first in the list, you could highlight it and click "Up". You can choose whether each attribute entry is required, or just optional. In "Field Edit Mode", the "Hidden" option lets you hide individual attributes on specific jobs so that prompted options are limited to only what you need. The "Read-Only" option ghosts the attribute and does not allow entry or editing, but still displays it in the field and specifically stores the default value shown. The setup screen for new attributes is shown below.



### Feature

In Use ←

Set: STRUCTURES

Attribute	Type	Req.	Editable	Select-Only
FENCE TYPE	Char	No	Hidden	No

Line:  Edit Up Down

Load Remove Add Save

### Edit attribute

Name:  Codes

Prompt:

Default Value:  Set Default

Type:  Req.:  Clear Default

Field Edit Mode:   Use List Only

List Values:

Woven Wire	Read-Only
Chain Link	Hidden
Barbed Wire	
Wood Rail	
Stone	
Privacy	

Add Remove Up Down



Fence type is a user-defined attribute. But many attributes of the feature are known by Carlson SurvPC (e.g. the current instrument being used, the date and time, etc.). These types of known attributes appear in a list of special codes, selectable above by tapping "Codes", and shown in the figure below.

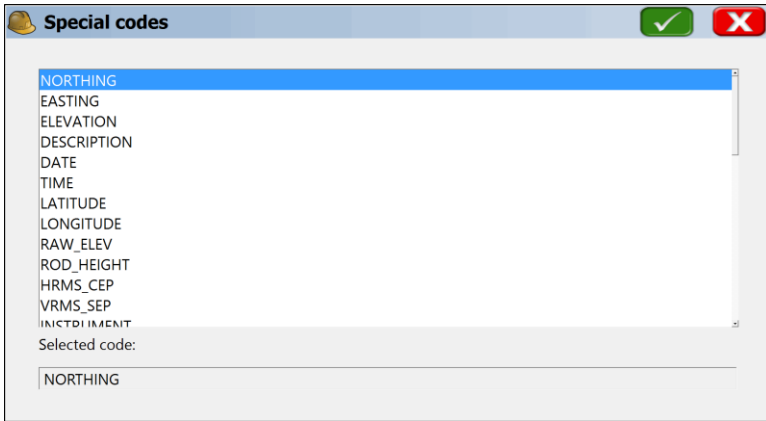

When you are collecting the points with an "FL" code, and the program detects that you have shot a "point-only" feature, or if you are shooting a line, that you have ended the line (e.g. FL END), then you will be prompted for the attributes. If, however, you select the Point option (lower left) for codes that involve linework, you will get prompted for attributes at each vertex, and then once for the line as a whole. In this way, you can be prompted for attributes of each pole on a power line, and then once for the entire power line (separate set of attributes).

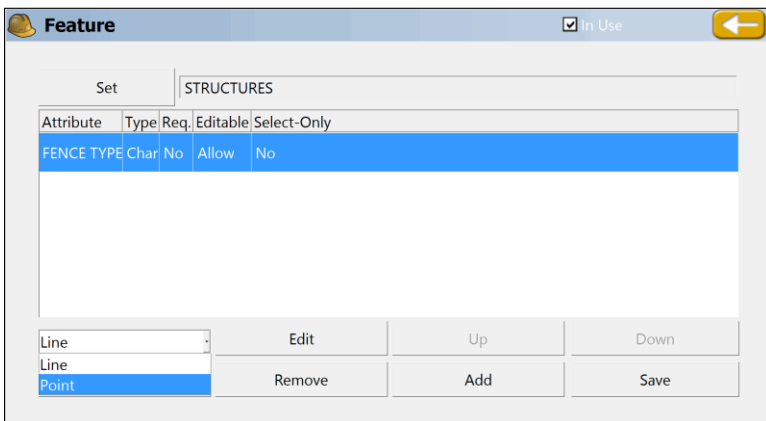

Note in the dialog below, you can set when you are prompted for the line attributes (start vs end of line). This screen is found within Special Codes, Settings (button at top of screen in Special Codes). The "Use FCL Path to Store \*.GIS" means that the folder used for the Feature Code File will also be the folder used for the \*.GIS files that are



made for each description with attributes. (This applies only to pre-SurvPC 2.51 versions). For example, if MH has attributes, a file MH.GIS will be created. If FH has attributes, a file FH.GIS will be created. These \*.GIS files normally store in the current job data directory, in a subdirectory called \CSGIS\FCLFileName (name of the feature code list file). Beginning in SurvPC 2.51, only one GIS file is made, and it always goes in the standard data subdirectory that contains the FCL file. Even this single file protocol is an option in SurvPC 2.51 or later, set by clicking on "Use Single Carlson GIS Features File" at the bottom of Settings within Special Codes. SurvPC 2.51 or later is backward compatible for use with earlier FCL files and will continue to use the coding system for attributes for FCL files set up by earlier versions, including file location protocols. The GIS file location protocol is shown below, based on a data folder called c:\data and an FCL file name called FieldCodes.fcl:

Prior to SurvPC 2.51

C:\Data\CSGIS\FieldCodes\MH.GIS  
C:\Data\CSGIS\FieldCodes\FL.GIS, etc.

SurvPC 2.51 and After ("Use Single Carlson GIS Feature File" clicked on)

C:\Data\FieldCodes.GIS

SurvPC also creates an \*.VTT file which contains the actual user-entered attributes. This file is associated with the CRD file. The combination of the CRD and VTT files are used to export the shapefiles under the Map Screen, Fill pulldown. If you wish to store the same attribute data on all vertices on a line, you can click on "Store GIS Line Data to All Vertices".

The "Save Only One GIS Feature to the Stored Pt" is a rarely used item which applies to field measurements with 2 or more codes (e.g. MH FH) where MH for Manhole and FH for Fire Hydrant both have GIS prompting associated with them. With this "Store Only One" clicked on, you would be prompted in the field for which item (MH or FH) to assign GIS coding to, and only one set of attributes are associated with the single point surveyed. If "Store Attribute(AT) to RW5 File" is on, then the attribute data also stores to the raw file, and can be viewed using FILE ® Raw Data ® Edit RW5 File.



## Special Code Suffixes

- **Special Codes:** In addition to the codes that you add to the Feature Code List, there are some predefined code suffixes that you may use to end lines or start curves. For example, FL END could end the fence line, with "END" being a predefined special code. The need to append codes is one reason that the "END" button on your PC is useful, to move to the END of the existing description so you can append a special code. You can substitute new codes for default codes, such that ".." can be substituted for "END" to end a line. To substitute a code, highlight it and enter the substitution characters at the bottom of the screen, in the "Code" entry box. The special code suffixes can also be entered as prefixes, as in PC EP (for start curve) rather than EP PC. Special Codes should be separated from your actual feature codes by a space. However, the alias of ".." can go right up against the feature code as in "FL..". The special codes are described below.

Code	Action
Space	Code Separator
None	String Designator
ST	Begin Line
EL	End Line
PC	Arc PC
PT	Arc PT
CLO	Close Figure

Carlson Code: ST Accept

- **ST & END:** Start and End Line. Some users prefer codes such as BL for Begin Line and EL for End Line, and ".." is another example of an "end line" code. You only need either to start or end lines to get new lines. You don't need to use both the start and end line coding. If you code 3 EP points as EP ST, EP, EP then the next new line can be EP ST again. Or you could just end the line as in EP, EP, EP END, then start again with EP. Another separate technique to generate unique lines is to add a number to the code, as in EP1, EP1, EP1. Then if you code EP2, EP2, EP2 a separate line will be drawn. In this case, you don't even need to use the start or end special codes. This allows you to mix the codes up as in EP1, EP2, EP2, EP1. In this case, the EP1 codes will connect and the EP2 codes will connect. See also the discussion below on "Auto-Detect Code Pattern" for techniques of cross-sectioning roads and other linear features. Within Configure, the option "Use Unique IDs for Linework" makes use of the EP1, EP2, EP3 concept by incrementing the appended number each time a new line is started using the line start code (e.g. ST) or the line start icon. With "Use Unique" on, the EP code becomes EP1 when you start a line, and if you use EP again and start another line, the code becomes EP2, etc. In this case, the ST code is retained (redundant but harmless) as in EP2 ST, EP2, EP2.



- **PC & PT:** Used to specify the point of curvature (PC) and point of tangency (PT) of a curve. If you are taking shots on a curve, use PC to specify the beginning of the curve and PT to specify the end of the curve. The PC special code will activate a 3-point arc automatically, so use of the PT code in a 3-point arc is redundant and therefore it is not necessary. You can even do a reverse curve by entering the PT instead as PC. However, if you are picking up a meandering stream or tree line, PT is useful to end the curving feature, and the program will “best fit” a curve through all the surveyed points between the PC and PT codes.

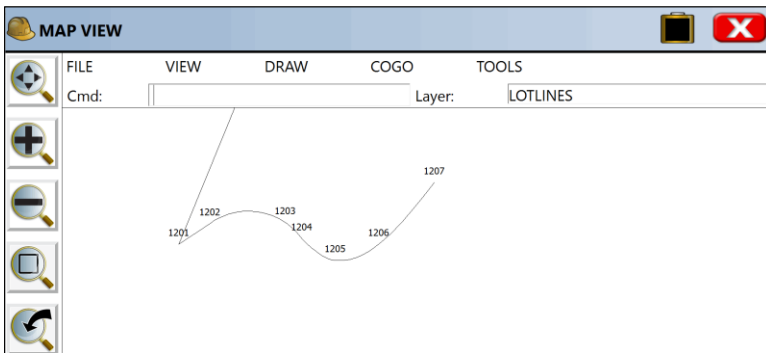

- **CLO:** Use this code to close a figure. This tells the software to close from the last point coded as CLO back to the first point of the figure. Note that after using a special code such as "CLO", appended with a space to the description code "BLD", that the program automatically removes the special code as it defaults the next description to "BLD". The "CLO" code also has the effect of ending the line and starting a new line. It only works with codes defined as 2D or 3D polylines.

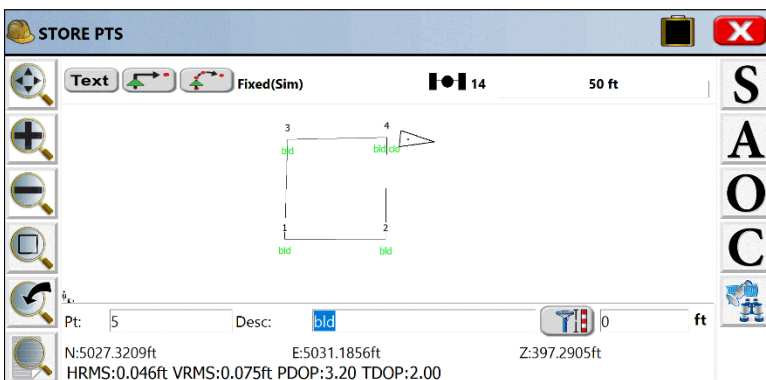





- **SMO:** Use this code to smooth the line through all of the points. This code must occur on the first point of the line.

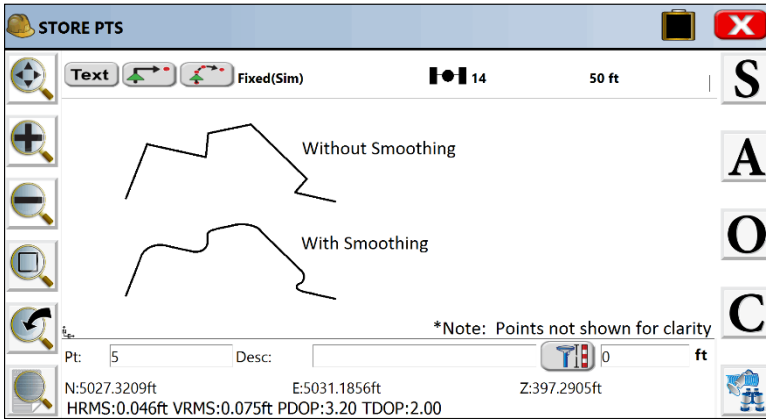

- **JPN:** Use this code followed by a point ID to create a new line segment between the current point and the entered point ID.
- **RECT:** This special code can be used in 2 different ways. You can take measurements to 3 sides of a building and on the third side, add the special code RECT, and the program will create a 4-sided building. Or you can measure two sides of a building and enter the distance right (RECT25) or distance left (RECT-20) to create the other, parallel sides. Both methods are illustrated below.

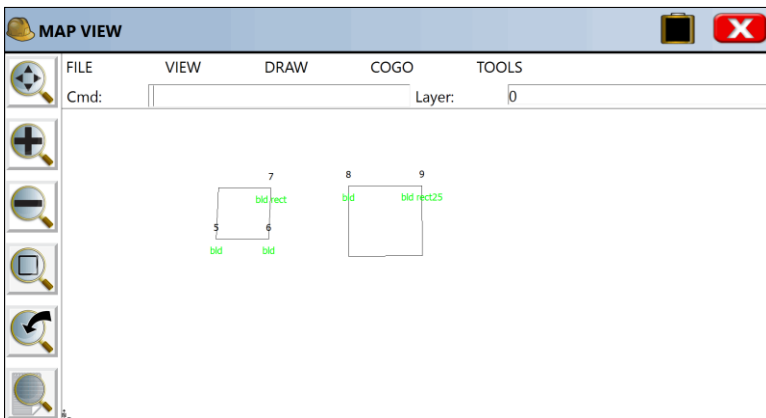



- **OH and OV:** You can also create horizontal offset lines and you can offset these same lines vertically as well by combining OH and OV as in EP OH0.5 OV0.5 (which might create a 6" over, 6" up back of curb parallel 3D polyline). You can even do multiple offset lines as shown below:

Point ID	Northing(ft)	Easting(ft)	Elevation(ft)	Description	Point ID
10	5007.46	5501.79	397.286	tr oh-5 oh-12.5 oh-17.5	10
11	5006.28	5513.80	397.303	tr	11
12	5004.77	5529.23	397.292	tr	12
13	5003.32	5544.02	397.304	tr	13
14	5001.93	5558.17	397.288	tr	14
15	5000.36	5574.24	397.307	tr	15
16	4998.72	5590.95	397.292	tr	16
17	4996.83	5610.24	397.288	tr..	17

This example here leads to a series of 4 parallel lines (for railroad tracks in this case), all offset to the left (negative) of the direction of the points 10 through 17.

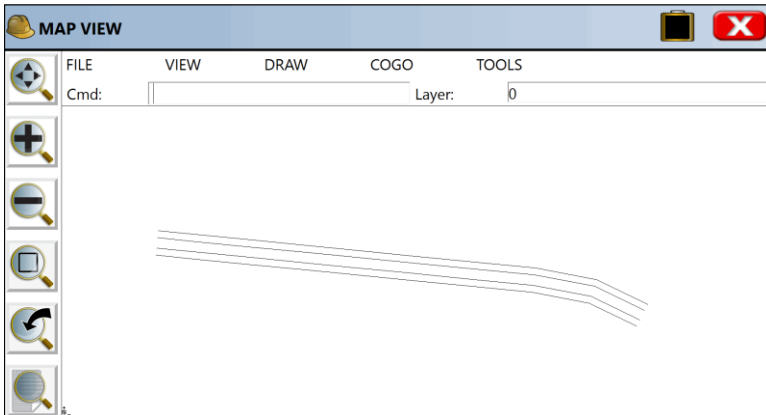

The OH and companion OV commands are flexible in that they can be entered after the first point measured, such as on point 12 or 13.

- **NE:** No Elevation. When a point is coded NE, it will not be used inside SurvPC for contouring or use in volumes. However, if a 3D Polyline is drawn connecting between points, the elevation will be used.
- **JOG:** This powerful option allows you to hand-enter right-angle extensions of the last line segment. So, if you have just measured 2 BLD points from 14 to 15, you



can enter 15 as BLD JOG 12 20 -5 10 17. Minus means left. This represents R12, R20, L-5, R10, R17. The effect is shown below:

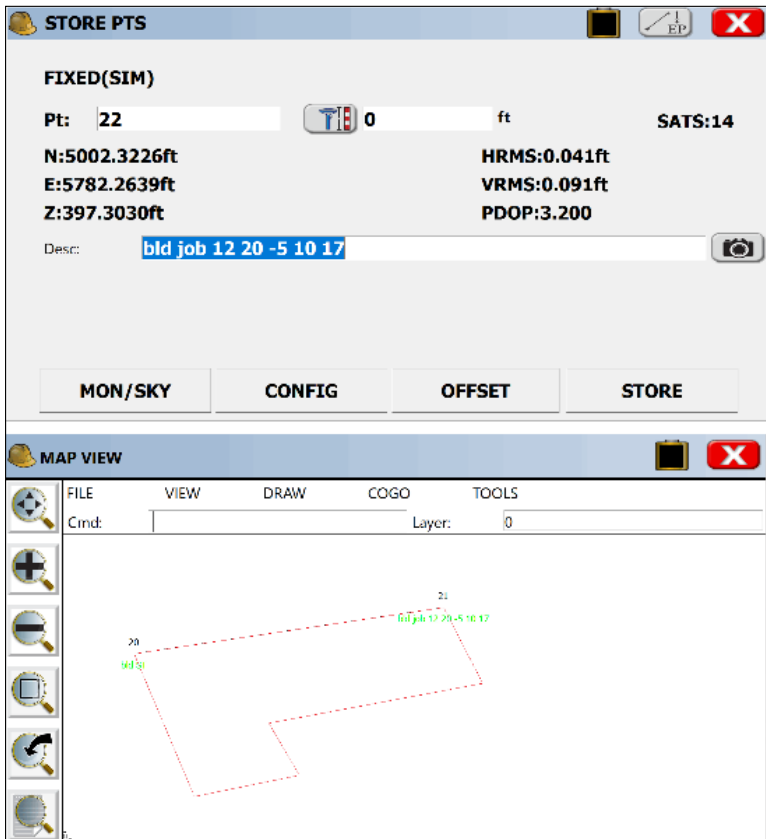

- **ZO:** Elevation Only. This is just a way of coding points as being important only for elevation, for processing typically in other software. It can be viewed as reference information on the point--only the elevation matters.



- **AFIT**: This code stands for "Arc Fit". It is used with 3-point arcs to avoid bulges caused by not picking the PC (start) and PT (end) of a true tangent curve accurately, in the field. When measuring curbs, it is common to get a bulging curve as shown below by picking point 9 too soon, still within the tangent, straight portion of the curb. Note that the EP2 PT description on point 11 is not necessary- the "PT" portion is assumed on a 3-point arc. Only the "PC" code on point 9 is necessary to initiate and draw this arc.

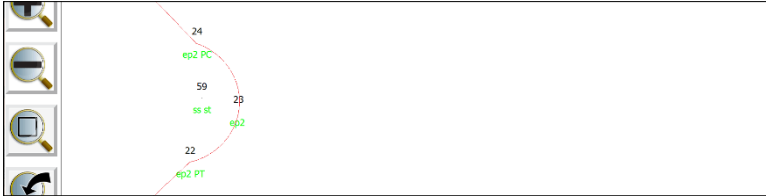

To remove the bulge in the arc and make it tangent, add code "AFIT" to point 10. If Line Details are clicked on within Configuration, the moment you add the text (click 10 directly in map screen and edit it), the line will redraw as shown below. In the field, if you add AFIT ahead of time, anticipating a bulging arc, it will draw correctly in the field.





- **CIR:** The Close Circular special code works 3 ways. First, with a single, measured point including a radius distance, it will draw a circle, as in CIR2 for a 2-meter or 2-foot radius (depending on units).

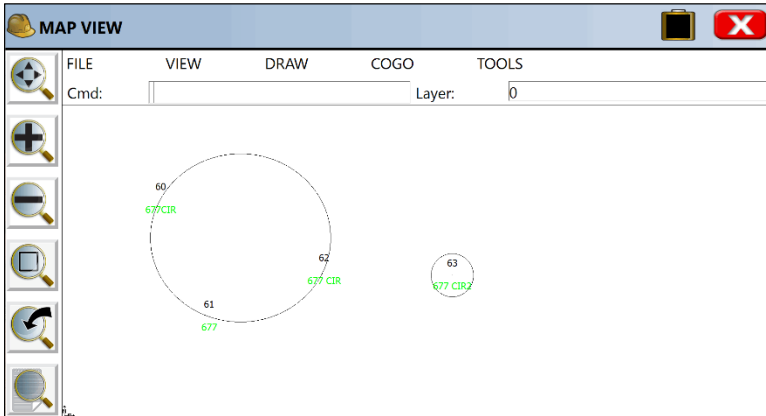

Secondly, if 2 points are used, then the radius becomes the mid-point of the 2 points and a circle will be drawn through both points with the entered radius:

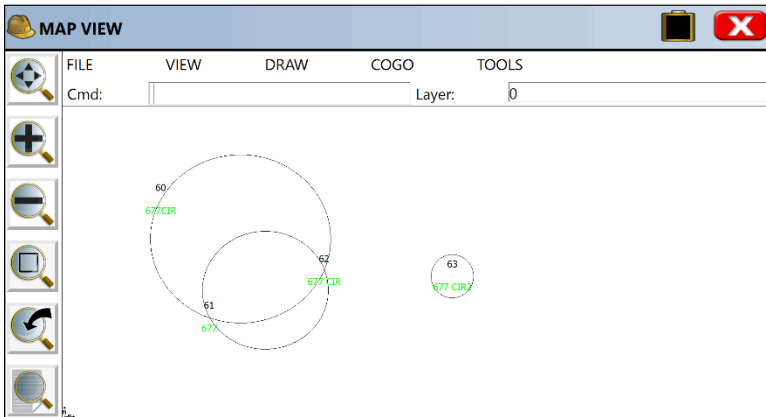

Third, if 3 points are entered as in 9 code CIR, then 10 code, then 11 code CIR, the third point defines a unique circle without user entry of the radius. The code used must be a linework code (like EP for edge-of-pavement), not a point code, for the circle to be drawn.



## Using Short-Cut Icons to Append Special Codes

With the Prompt for Height and Description turned on within Configure, you have the opportunity to choose from your existing descriptions saved in your Feature Code List, whenever you store points. You also have the ability to select icons for the special codes as shown here:

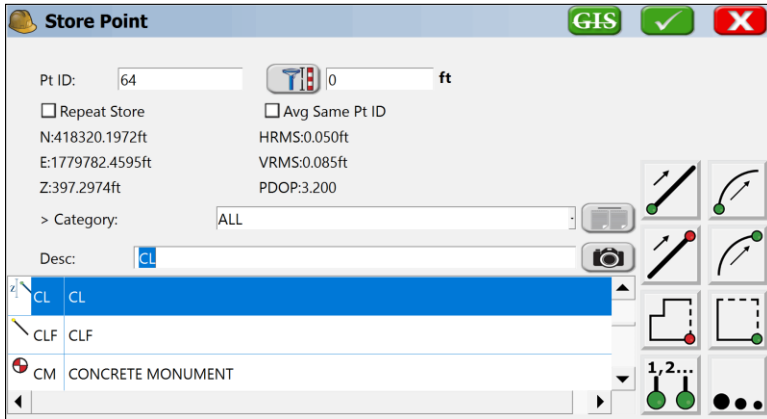

On the first page, these codes going from top to bottom, starting at the left, represent start line, end line, close line, select active line (when multiple lines are being drawn with the same code), start curve, end curve, rectangle, and "more". When you pick more, the options are offset horizontal, offset vertical, smooth curve, select active line, join to point ID, no elevation, jog and more (return to first set of icons).



## Pre-Formatted Special Codes

SurvPC has several pre-made files of codes used by certain highway departments and others. These can be selected from the drop list by selecting Special Codes within the Feature Code command. The actual DOT code files (at right below) can be loaded from the Knowledge Base on the Carlson website, as outlined below.

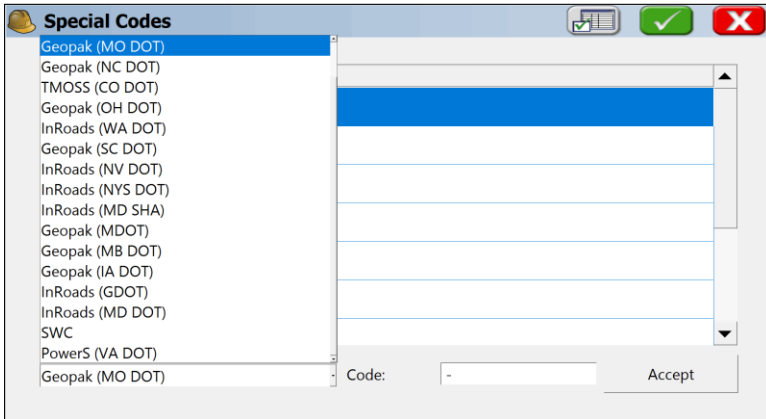

When a specified format is selected such as Geopak (MO DOT), the standard codes all change, including the separator code. Whereas for normal coding, a space is used to separate a description from a special code (e.g. EP PC), with MO DOT coding, a "-" (dash) would be used as the separator, as in EP-EC. The users of these systems need to be familiar with the required coding. For example, with Geopak (MO DOT) coding, a typical edge of bituminous survey might be coded: 201-BS, 201, 201, 201-C, 201-C, 201-EC, 201, 201-ES. Note that Geopak requires a start line and end line and requires coding on all arc points (C or EC). This coding will process correctly in SurvPC, but SurvPC will also process this coding if the "-BS" is omitted on the first measurement. Use of the special icons within the Hgt/Description prompt screen will append the correct special codes that are active. Geopak also requires points to process linework, so it will not respond to the OH feature and the CLR feature, unless "Create Points for All Linework Elements" is turned on within Settings. (This option appears only if the program detects coding systems requiring the option). Otherwise, OH will create offset lines, for example, with no associated points.

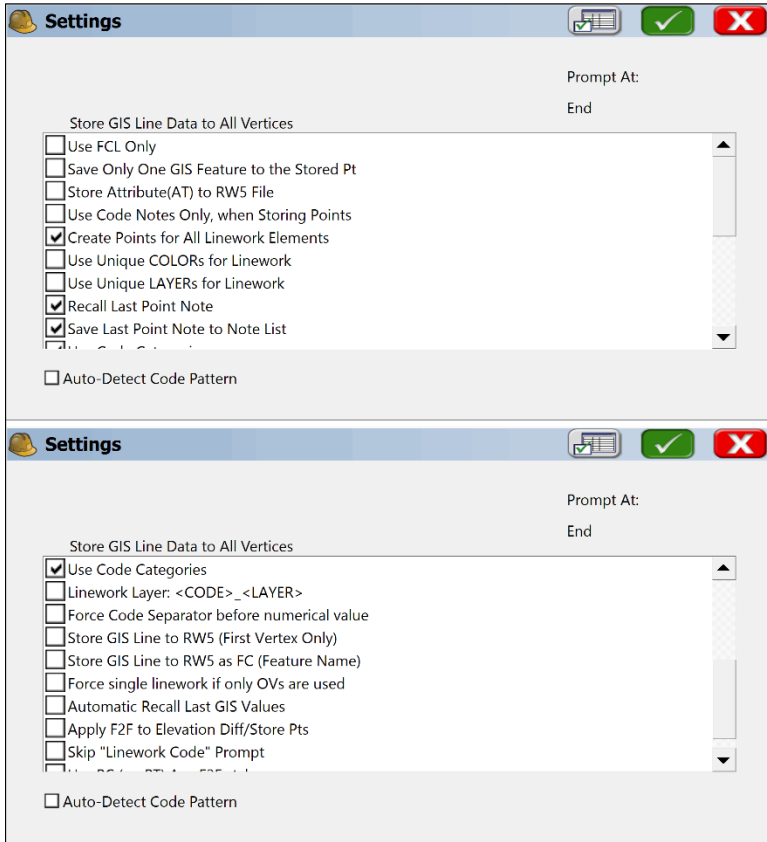

The various coding systems used by different state highway departments can be loaded at the following locations:

The DOT FCL files are all available at [www.carlsonsw.com](http://www.carlsonsw.com) – [here](#).

*Category: SurvPC*

*Topic ID: 388*

*Title: DOT Feature Code Lists*

*Also, the following link will open the Knowledge Base 388 article.*

*[http://update.carlsonsw.com/kbase\\_main.php?action=display\\_topic&topic\\_id=388](http://update.carlsonsw.com/kbase_main.php?action=display_topic&topic_id=388)*





## Other Settings

**Use FCL Path to Store \*.GIS:** It is recommended that this option be clicked on. If your feature code file is in the \data subdirectory, then the ".GIS" files which contain attributes will be placed in the \data subdirectory also. This keeps the attribute prompting linked to the feature code (.fcl) file. If GIS attributing is being used, you can store the GIS data directly into any special subdirectory used for the applicable Feature Code List. So if you maintain several feature code lists, each with attributing specified for certain descriptions, the GIS attribute data can be placed in the directory of the associated feature code file. The only advantage of turning this off is if you wanted attributing to be associated with the job file as opposed to the feature code list.

**Store GIS Line Data to Vertices:** When lines are created by field coding, points at the vertices are also created (except for features created by RECT and OH). In addition to associating attribute data with the linework itself, you can click this option to store the GIS attribute data to each point on the line that was surveyed.

**Use FCL Only:** If this option is selected, the Height/Description prompt screen shows only the feature codes in the list and will not display others descriptions used in the current job. This simplifies the code selection process when the goal is to more strictly limit codes to those in the list.

**Save Only One GIS Feature to the Stored Pt:** When two codes are entered for the same point, separated by a space, and both codes lead to GIS prompting, only the first code will be used for the GIS prompts and stored attributes.

**Store Attributes (AT) to RW5 File:** All attribute data will store at "AT" records in the raw file. For example, multiple attributes entered for a manhole might appear as shown below. The name of the attribute is identified with a "TN" prefix and the value of the attribute is identified with a "TN" prefix.

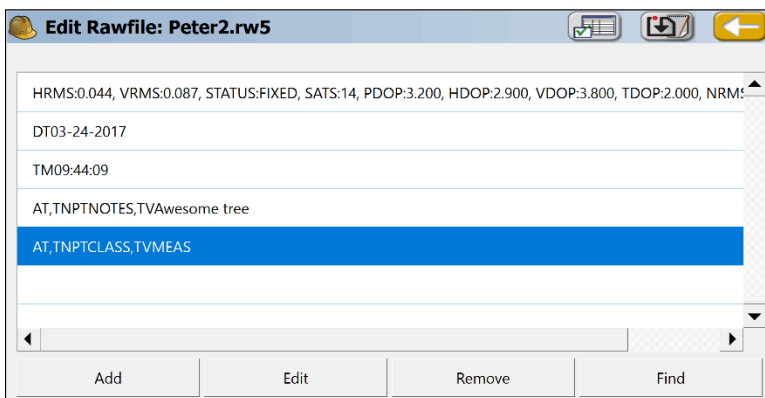



**Use Code Notes Only, when Storing Points:** This is a method that allows storing more than 31 characters for point descriptions (the normal limit for CRD files). First, you must turn on "Prompt for Point Notes" within Configure. Then, a code such as "CP" can be associated with a long note, such as "Control Point from City Record Book 12-A". You would then select that single note each time and save typing of notes. The notes can then be exported with the points using File, Import/Export. Using File Export, one technique is to set the delimiter on the coordinate values (Pt ID, N, E, Z, Description) to comma and on "Other" (e.g. the note) to Space. In this way, within File Export, you can append the long note to the description as a single field to be imported and used by any office software.

Another use of this option is to limit the list of notes that appear to just those associated with the Feature Code. For example, if you want to use Notes to describe the type of tree just measured in association with code "TR", then you can use the "Notes" option within Feature Codes, option Add or Edit to establish the list of trees as Notes, and then only that list would appear if "Use Code Notes Only" is clicked on. Shown below at left would be all recent notes, then the more limited list with "Use Code Notes Only" turned on.

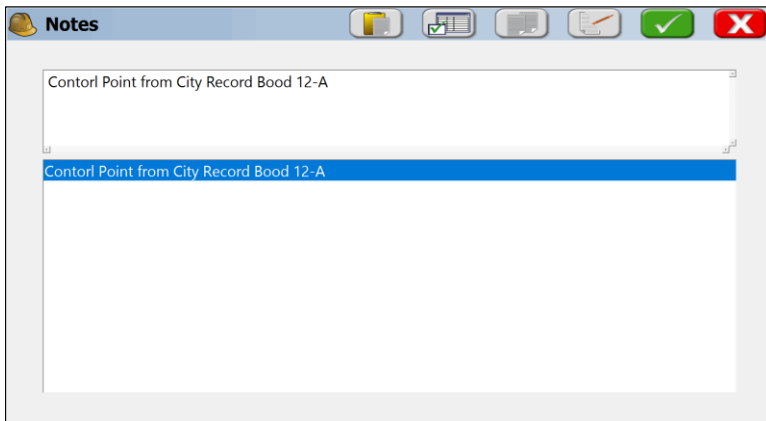

The 4 buttons along the top of the dialog represent Select Note, Clear Note, OK and Cancel.

**Create Points for All Linework Elements:** When using OH or other codes such as RECT for Rectangle, this option creates a Point ID at all vertices of linework, whether surveyed or created by the software. Some office software packages, like earlier versions of Geopak, required point IDs to process coding. Points are increments sequentially from the last entered point. The option only appears when certain special code formats are selected, indicating linkages to office software needing Point IDs.

**Use Unique Colors for Linework:** Produces different colors, increasing sequentially from 1 to 7 (Autocad (r) color conventions), for each new version of the same feature code (e.g. EP). After color 7, it goes to other distinct colors.



**Auto Increment Layers for Linework:** This appends numbers to the linework layer as you make new lines for the same feature code. So, if EP makes lines in the ROAD layer, then the first EP line goes to ROAD1, the next line to ROAD 2, the third line to ROAD3, etc.

**Recall Last Point Note:** Recalls and applies to the newly stored point whatever point note was used last.

**Save Last Point Note to Point List:** With this On, all notes that are entered are saved to a file of notes making a Note List (see above graphic). Then users can select previously entered notes from the list, to save typing in the field.

**Use Code Categories:** When On, Categories appear in the Feature Code List and descriptions can be associated with Code Categories for easier sorting. With the option Off, Categories do not appear in the Feature Code List, and an additional 2 lines of Feature Codes (8 total) can display at one time based on the extra space made available.

**Auto-Create Linework Layer: <CODE>\_<LAYER>:** This option changes the layer dynamically by appending the code to the layer. So, if both FH (fire hydrant) and MH (Manhole) are defined to be in the Utility Layer, this option will place them in the FH\_Utility and MH\_Utility layers.

**Force Code Separator Between Code and Value:** It forces in HGT/Desc to add the separator value (usually "space character") if not present. If you tap, EP, you end use with EP<space> and then you could type, "2" string 2.

**Store GIS Line to RW5 as FC (Feature Name):** Adds an entry as FC record (usually processed by Bentley Office software). To the RW5 file. FC,PN4,FNfence (Feature code, Key, Feature name).

**Force Single Linework if only OV's are used:** It allows to, set each vertex to have a different Elevation. Usually, we create individual new lines using the OV, every time we change the values. If on we create one single line with different elevations per each vertex.

**Apply F2F to Elevation Difference:** This will enable Field to Finish during the Elevation difference command.

**Warn on Repeated Code:** This option allows SurvCE to warn the user that a code used has been repeated.

**Use PC (no PT) Arc, F2F Style:** Style of no PT. Usually requires a PC, one extra point and the end of the arc (no PT note). Need it for Office software which is not Carlson. Power Survey, InRoads, etc.



**Storing GIS Attrib. Time HH:MM (No Seconds):** This option allows for feature codes with time-related attributes to be stored in Hours: Minutes format, thereby eliminated the seconds field.

**Auto-Detect Code Pattern:** With the option selected, the program will look for patterns of cross-section style coding, particularly applicable to roads and ditches. In the simplest example, consider a ditch or stream being surveying to 3 points: (TB for Top of Bank, DL for Ditch Line and TB for Top of Bank on the opposite side). So, consider the Left-to-Right pattern of surveying below:

*TB1, DL, TB2*

*TB1*

Right at the point of entering TB1, the program will detect a pattern and will assume the next point is DL and the point after that is TB2, and will default to prompting for that coding. Similarly, consider a L to R then R to L survey:

*TB1, DL, TB2*

*TB2*

In this case, with **Auto-Detect On**, the program will prompt next for DL and then for TB1, and then TB1 again, DL and TB2. This same pattern recognition applies to 5 point cross - sections such as CB1, EP1, CL, CB2, EP2 and any number of pattern-based cross - section examples. When a new pattern is detected and the program is about to launch into auto-assignment of descriptions, you will be prompted:

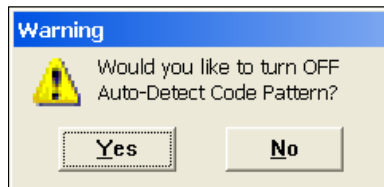



You can survey points outside the pattern by simply entering a different code. The program will then resume auto-assigning the code based on the recognized pattern. Whenever Auto-Detect is on, it is advisable to review the automated code to be certain it matches what is intended. The button: "1.2.." in the HGT/Desc dialog gives you the option to:

- turn *ON/OFF* auto-detect pattern.
- check the codes that are making the pattern.
- skip a code.
- clear the codes that are making the pattern.

### Line Details

When conducting field measurements in the command Store Points, if an existing line created by Field Codes is clicked, on the line but away from the corner points (to avoid Point Details), then an advanced "Line Details" option appears as shown:

The screenshot shows the 'STORE PTS' software interface. The top panel displays a 3D Polyline with points labeled 1201 through 1206. The bottom panel, titled 'Line Details', provides the following information:

Source:	Field Code	
Type:	3D Polyline	
Code:	EP	Change
Status:	Active	Change
Layer:	EOP	Change

Additional options at the bottom include: View Attributes, Delete Line, Extend Line, and New Line.



The line is picked. Because the picked position is sufficiently distant from the corner point, the program recognizes that a line has been selected and "Line Details" options appear. If the line is extended, it will extend from point based on the next measured point. If the line is deleted, it will be erased. Codes, status and layers can be changed. If the goal is to start a new line from the nearest endpoint to the next measured position, then the "New Line" option would be selected. The new line could be a fence line in a completely new layer, as shown below:

The screenshot shows a software interface for a surveying application. The main window is titled "STORE PTS" and contains a map area with several points labeled 1201 through 1206. A line is drawn between points 1201 and 1202. The interface includes a toolbar on the left with various icons for navigation and editing. Below the map, there is a status bar showing coordinates and other data: Pt: 1208, N:1508175.8727ft, E:9148741.3284ft, Z:397.2945ft, HRMS:0.049ft, VRMS:0.096ft, PDOP:3.20, TDOP:2.00. A "Line Details" panel is open at the bottom, displaying the following information:

Source:	<b>Field Code</b>	
Type:	<b>3D Polyline</b>	
Code:	<b>EP</b>	<input type="button" value="Change"/>
Status:	<b>Active</b>	<input type="button" value="Change"/>
Layer:	<b>EOP</b>	<input type="button" value="Change"/>

Below the "Line Details" panel, there are three buttons: "View Attributes", "Delete Line", and "Extend Line". A "New Line" button is also visible at the bottom right of the interface.



In this way, new lines can start from end points of existing lines without the need to re-survey them (which saves time and is particularly beneficial in high-traffic areas). Even though only one new measurement was taken in this example, a 2-point line is drawn, and the code for the point is updated to include the original text as well as the new text. The program cautiously uses both the start code (ST) and the concept of the numerical version of the code (FL becomes FL1, first fence line) to start the line, even though the combination of FL1 and ST is redundant. If a point is the end of the line, and "END" is the special code to end a line, then the point is coded FL1 END.

Station	Description	Pt ID
603	mh	11
600	mh COVERDIAM:30" MATERIAL:Preca	12
600	MH NE COVERDIAM:30" MATERIAL:Pr	13
603	BLD ST FL1 ST	14
603	BLD Joq 12 20 -5 10 17	15
836	CB	20
603	ep	21
603	ep	22
603	ep	23
603	ep END	24
603	ep	25

Buttons: Edit, Add, Find, Delete

Even though point detailed was the newly measured point, the previous point is auto-updated to include BLD ST FL1 ST (start building, the original code and start fence line, the new code). The Line Details process therefore saves field measurement time and field coding time. Line Details, like Point Details, is a transparent or "context-sensitive" command. Simply pick the line or point, without issuing any command, and the options appear. If you do so within the Store Points "context", additional prompting occurs as discussed above. This also applies to Point Details, as described below.



## Point Details

When conducting Store Points and using Field Codes, the picking of a point on the screen, in this context, allows for the re-measuring of the point, to correct the field-to-finish linework and symbol placement. (Even if field codes are not being used, picking any point within Store Points allows for re-measurement of the point.) So, in the example above, picking point 1210 leads to the screen shown below, and the new result if re-surveyed. The original field code will be the default description, but you have the option to change it.

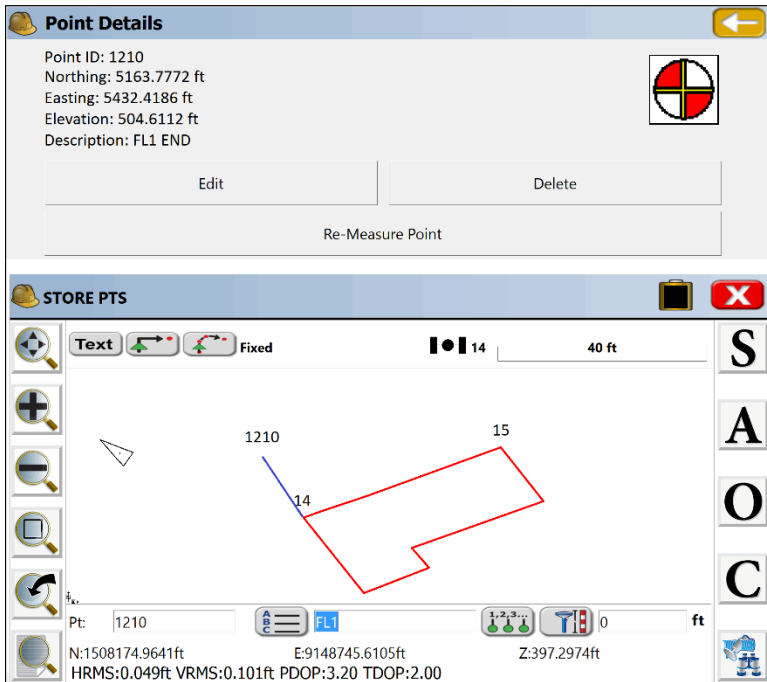

The result of the new measurement is shown below:



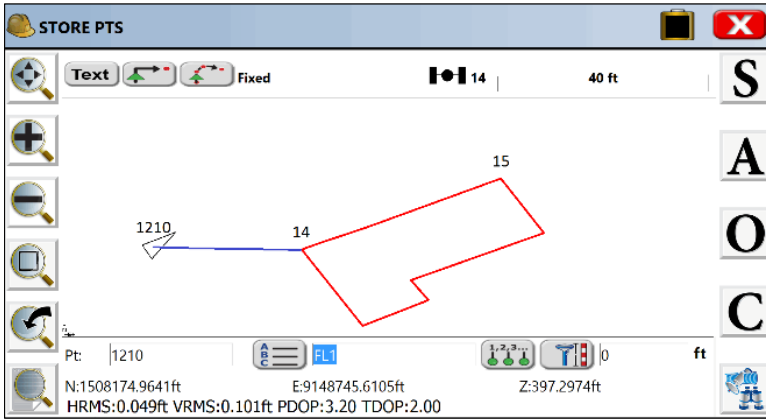

### Reprocessing the Field Codes

Using the command **Field to Finish**, found under the Tools pulldown menu in the Map screen, you can reprocess your field codes after editing any aspect of your point data. So if you left off an "end line" command, you can edit the point, change the description, and re-process the linework. In the example using the code RECT25 above, if you edited that point and changed it to RECT50, it would draw a twice as large building when you run **Field to Finish**, and RECT-25 would draw the same building but instead in the opposite direction. If you click on Show Line Details under Configure, this reprocessing is fully automatic whenever a graphic screen is displayed, whether in active survey commands or by going to the Map screen.



## 4.10 Data Transfer



This command prepares Carlson SurvPC for transferring data to and from a desktop PC or to a USB stick (thumb drive). For Data Transfer to a PC, a program on the PC must be running to receive and send files. SurvPC, using the Data Transfer option, must “handshake” with the program on the PC in order for the transfer to be successful. A serial cable must connect the PC to the handheld device running SurvPC. COM ports must be identified correctly, as well as baud rates. The USB transfer option is part of the "Copy to Storage" feature.

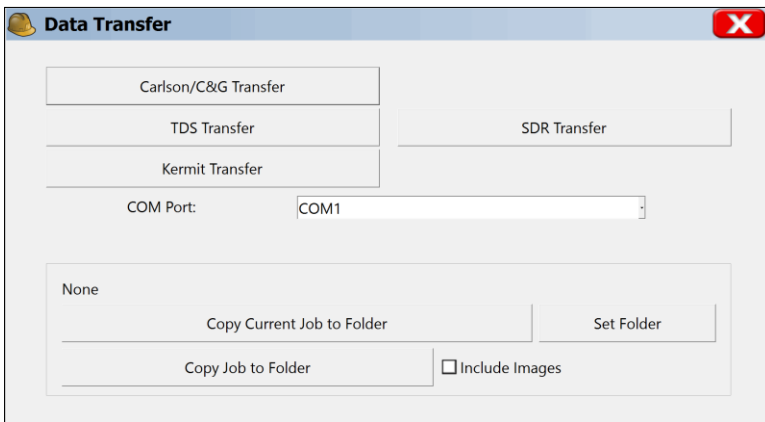

- **Carlson/C&G Transfer:** This option is designed to work with Carlson Software and C&G office products (Carlson Civil, Carlson Survey, Carlson Survey Desktop, Carlson Connect in older Autodesk products, X-Port, CG Survey and SurvNET). It also works with the standalone SurvCom program that is included with the purchase of SurvPC. The handshake is designed for simplicity and robustness. Carlson Software products use the same native file formats as SurvPC, so no file conversion occurs — only transfer.
- **TDS Transfer:** This command is used to transfer data from SurvPC to TDS Foresight or other programs that have a TDS Link routine.



- **SDR Transfer:** This command is designed to work with existing programs that communicate with the SDR. For example, if you have LDD, Intergraph, SurvCADD/Carlson Civil, SelectCAD or other software that contains an SDR33 transfer routine, then this option is designed to mimic that protocol. When an RW5 file is selected, it is automatically converted to a Sokkia RAW file and downloaded to the PC. When a CRD file is selected, it is automatically converted to a Sokkia RAW file with "08" records for points. This allows you to use and process the data in SurvPC similarly to the data in the SDR33. You can also upload into the SurvPC field computer Sokkia RAW files that contain point records. All the points will be stored in a CRD file on SurvPC.
- **Kermit Transfer:** This command leads to a send and receive screen that works with the Kermit program on the PC. This is a readily available data transfer program.
- **Set Folder:** This option should be selected prior to choosing "Copy Current Job to Folder" or "Copy Job to Folder". The "Set Folder" option allows you to set where the "Copy to Storage" commands will place the files. Where USB output is available, the USB (thumb drive) port is designated as "Hard Disk". You can also store to the CF Card, which is the "Storage" option, and you can store to the SD Card. On the Carlson Surveyor and Surveyor+, the USB thumb device (Hard Disk option) is the default.

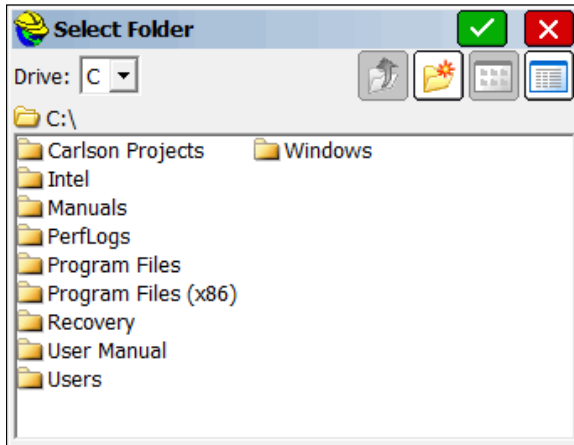

- **Copy Current Job to Folder:** This copies the entire current Job, all files associated with the current coordinate file (CRD file), to the selected storage option. This would include the RW5 file, the DXF file (drawing portion), the VTT file (containing GIS data), basically every file sharing the same name as the CRD file.
- **Copy Job to Folder:** This copies the selected Job or CRD file to storage, which can be different from the current file. When the current job or selected job files are copied, the program displays: "Process Done".



- **Include Images:** This allows the user to copy images associated with job attributes.

## 4.11 Import / Export



This command allows you to import an ASCII file to job data or export job data to an ASCII file. When you choose this command, you will see a secondary dialog in which you will be prompted to choose to Import or Export.



### Import ASCII File

This command converts point data from an ASCII text file into the SurvPC format. The source ASCII file can contain any combination of point number, northing, easting, elevation, and description. You may select any of the predefined formats or create your own custom format. Since some of these source file formats (like Carlson CRD and TDS CR5) are not ASCII but are actually binary, Import ASCII file can be used to import points from certain non-ASCII type files. This next figure shows the Import ASCII dialog box.

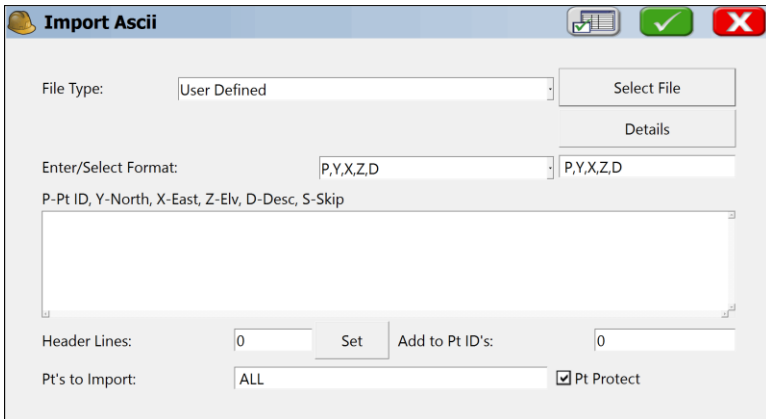



- **Source File Format:** You must choose the format of the source file. The choices include
  - User Defined:** For importing most .TXT and .ASC files. The coordinate order in the Choice field is used.
  - Traverse PC:** For importing Traverse PC .TRV files.
  - TDS:** For importing TDS .CR5 files. Note that CR5 files can contain point numbers in excess of 32760. If point IDs exceed that value, it is best to set **Alphanumeric** as the point ID type under **New Job** in **Job Settings** prior to importing.
  - Geodimeter:** For importing Geodimeter .OBS files.
  - Trimble POS:** For importing Trimble .POS files.
  - CRD / CRDB File:** Allows you to import a SurvPC CRD / CRDB file into the current, active CRD / CRDB file, and set the range of points to import. Note that this method can be used to move a subset of points from one CRD file over to another file, as shown below. You can import "All" points or just points 101 to 110, as needed.

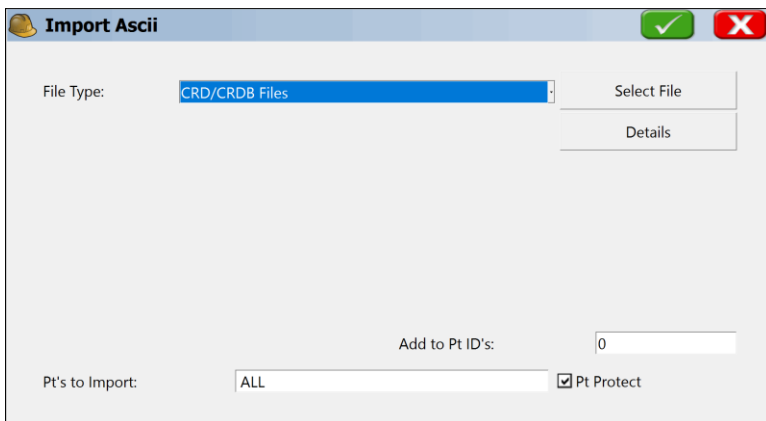

**SDR File:** For importing point data within Sokkia SDR files.

**MMH File \*.360, MOSS, SDMS, CAICE:** Other formats that can be imported. SDMS, for example, is a format for both points and raw survey data that was developed by AASHTO.

- **Select File:** Type in or browse for the name of the file to import.
- **Details:** Only after a file has been selected, Details can be clicked to show the range of points detected in the file.
- **Enter/Select Format:** If your Source File Format is set to User Defined, choosing one of these settings copies the contents into the Choice field, which will be used to import the file.
- **Choice Field:** If you are importing an ASCII file with a special form (e.g. A,Survey,1254552.123,498135.12,1109.23,iron pin,54) then you want a format that skips the first two columns (A and Survey) and does Easting (X), Northing



(Y), Elevation (Z), Description (D) and Point ID (P), so your format will be: S,S,X,Y,Z,D,P. If there is no point ID in the ASCII file, you simply omit the P in the entered format, and the program will prompt for a starting point number or ID and will number each subsequent point sequentially.

- **Preview:** Shows you a preview of the first line of the ASCII file. This is helpful in determining the correct coordinate order format.
- **Header Lines:** Specifies the number of header lines to skip in the ASCII file.
- **Set:** First highlight the last of the lines in the "Preview" that you want to skip, and then clicking this button sets that specific number of header lines to skip. If all the display lines are valid coordinates, you would not use the "Set" option and would enter "0" header lines to skip.
- **Add to Pt ID's:** Specifies a value to be added to each point ID during the import process. If you added a value of 100, then point 1 would become 101, point 2 would become 102, etc.
- **Pt Protect:** Specifies whether or not to check each point ID to see if it already exists in the current CRD file. If this is toggled ON and you attempt to import point ID's that already exist, you will then be prompted to overwrite each existing point or to cancel the operation.
- **Settings:**  Notes can also be imported and will associate with point IDs. Settings allows control of the separator used between the point ID information and Note on the ASCII Import (comma, tab, space or "other" as specified).

### Export ASCII File

This command converts SurvPC point data to an ASCII text file. The next figure shows the Export ASCII dialog box. Choose a coordinate order, type of delimiter, range of points and precision. After choosing the settings in this dialog box, press OK. A standard file dialog will appear. In this dialog, choose a name for your ASCII file and then press OK. After the file is written, a dialog will appear telling you that the conversion is finished.



**Export Ascii**

File Type: User Defined

Coordinate Order: PT\_ID,North,East,Elev,Desc Config

Delimiter

Comma  Space  Tab  Other

Range: 1-2 Export

Precision: 0.0000 Other:

Point Notes

Point Info

Attributes

Format Geodetic

- **File Type:** The user may specify the File Type. Selections for File Type are: User Defined, MMH File \*.360, MML ETRS File \*.mml, KML/KMZ File \*.kml/z, SWC File \*.swc, JUPEM TXT File \*.txt, SDR Raw File \*.sdr, SDR Point File \*.sdr, TDS File \*.rw5, and Pregeo \*.dat.
- **Coordinate Order:** You must specify the output format for the ASCII file. There are seven different formats to choose from. The last field is always the description. The fields can be space, comma or tab delimited, and you can also separate the fields by a user-defined delimiter. Two of the options include quotes around the description field so that your descriptions can include spaces and/or commas. An additional option, "Custom", appears at the bottom of the drop list. If this option is selected, the "Config" button becomes active.
- **Config:** With Custom selected for Coordinate Order, Click "Config" to see the dialog options below. Note that if Latitude and Longitude is included in the output, the "Format Geodetic" option in the dialog also becomes active.

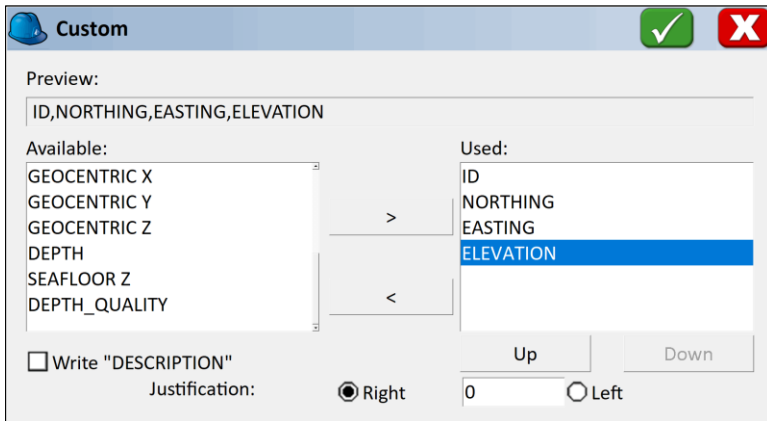

- **Type of Delimiter:** You must specify the character used for delimiting the fields in the output ASCII file. You may choose either a space, comma, tab or user-defined delimiter.
- **Coords vs Other:** As shown in the first graphic above, you can use one delimiter for the coordinates and another for the "other" information such as notes and GIS attribute data. If, for example, you had notes that were types of trees associated with the "TR" description, then the tree type could be appended to the code TR with a space, as in TR OAK, and export as a single field. You can control whether or not you choose to export notes, point info and point attributes.
- **Range:** You must specify the range of points to output. Ranges can be separated with commas, as in 1-40,101-199,A1-A44.
- **Export Notes:** When this option is enabled, any point notes associated with the current job will be exported to a .NOT file. These files are used with SurvCADD (and other Carlson office software products).
- **Export Point Info:** This will export any "known" information about the point, such as HRMS and VRMS values that have been included automatically in the Note file.
- **Export Attributes:** GIS attributes can be assigned to points that are stored based on settings in the Feature Code List. If a point that is shot is a manhole (e.g. MH) and attributes such as concrete, 5 rungs, 2 inlets are entered for this point, these attributes will be exported to an ASCII file for use by external programs when this option is enabled.
- **Precision:** You must specify the output precision for northings, eastings, and elevations. This setting does not affect point IDs or descriptions. After choosing the settings in this dialog box, press OK. A standard file dialog will appear. In this dialog; choose a name for your ASCII file and then press **OK**. After the file is written, a dialog will appear to let you know that the process is finished.
- **Format Geodetic:** Based on setting of Custom for Coordinate Order and use of Latitude and Longitude in the export "used" list, the Format Geodetic button becomes active. You can select from many Geodetic formats for the Lat and Long, plus control notation and location of the notation, as shown below.



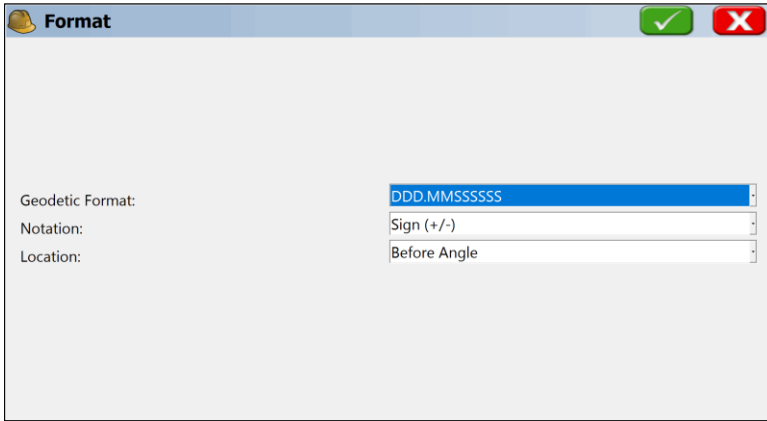

- This next figure shows the result of exporting a job to an ASCII file.

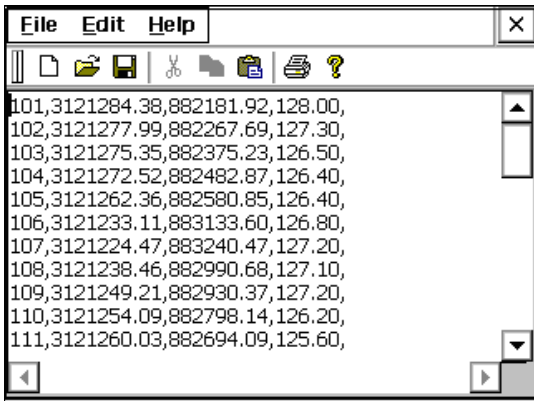



## 4.12 Delete Job



This command allows you to remove any existing file from any directory to free up memory. This figure below shows the standard file selection dialog, where you can choose the file name to delete.

*Note: It is always a good idea to back-up your data by transferring it to a PC before deleting files. Carlson SurvPC does not require you to back-up your data before deleting.*

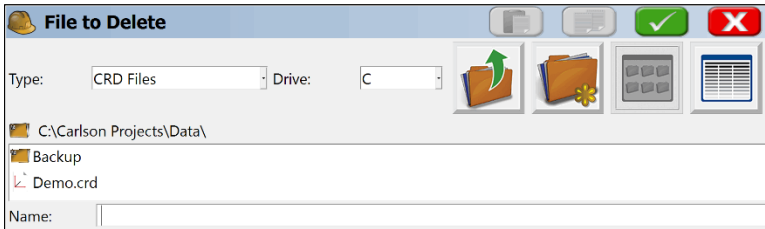

Select the file you wish to delete from the standard file selection dialog box and pick **OK**. SurvPC will ask if you want to delete all files associated with the job (e.g. the .dxf file, the .rw5 file, etc.).

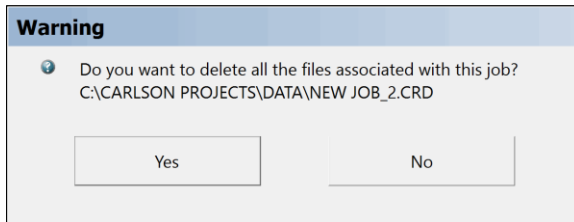

Press Yes, if you wish to continue. SurvPC will then warn you if the file or files to be deleted have never been downloaded before.

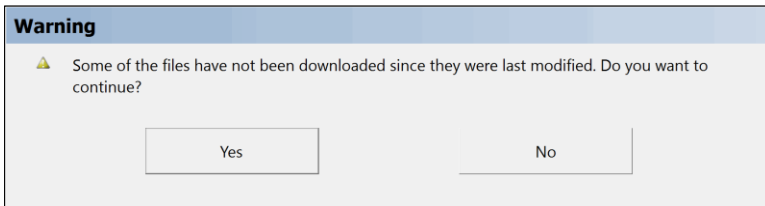

Press Yes, if you wish to continue. You will be asked to confirm your file selection once more. Press Yes to accept the deletion of the file or files, or No to cancel the selection.



## 4.13 About Carlson SurvPC

This command allows you to view information about Carlson SurvPC and your registration.

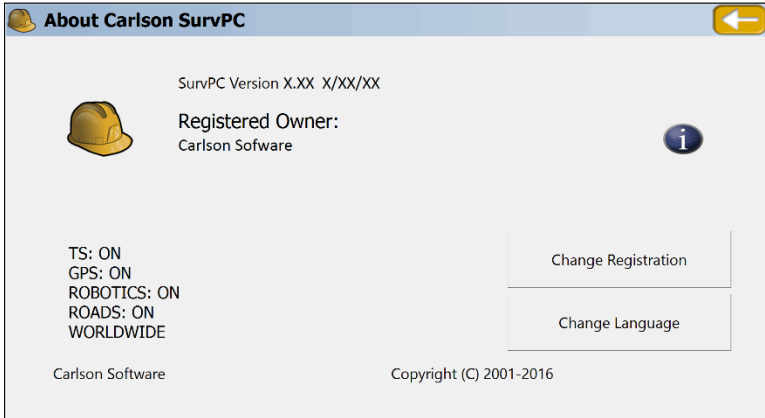

### Change Registration

The Change Registration button will open the SurvPC product registration dialog box. This dialog will allow the user to register SurvPC.

### Change Language

The Change Language button will allow you to select the preferred language used in SurvPC.

## 4.14 Exit



This command will exit the Carlson SurvPC program. The software presents the confirmation dialog.

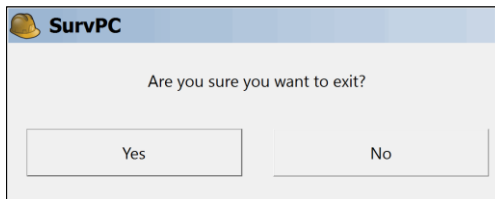

If you choose Yes, SurvPC will exit and your data files are saved. If you choose No, SurvPC will not exit.



## 5 Equip

This chapter provides information on using the commands from the Equip menu.





## 5.1 Total Station



The Total Station routine allows the user to configure their total station communication and operation settings. The tabs shown are configured based on the selected instrument (see specific instrument for details). It is recommended to go left to right through the tabs, from Current to Comms to Settings to Search, to ensure that all settings are correct, especially when first configuring a new instrument. Click the green check mark (not the red X) to accept all changes and continue. Some models of equipment do not have Settings or Search.

### Current Tab

Select first the manufacturer and then the model. The routine also provides an instrument recall feature that allows the user to store and recall all instrument-related settings as a user named configuration. Configure all of the settings as desired and select the save button to name and store the custom configuration. Settings that will be retained are as follows:

- Instrument Settings
- Communication Settings
- Configure Settings
- Stakeout Reference Settings

The screenshot shows a software window titled "Instrument Setup". It has four tabs: "Current", "Comms", "Settings", and "Search". The "Current" tab is active. Below the tabs, there are two dropdown menus: "Manufacturer:" with "Leica Robotic" selected, and "Model:" with "TS15/TS16" selected. Below these is a large empty text area. At the bottom of the window, there are four buttons: "Load", "Save", "Delete", and "Defaults". In the top right corner of the window, there are three icons: a blue gear, a green checkmark, and a red X.

- **Load:** This button will load all settings defined by the selected icon.
- **Save:** This button will save the current settings and allows the user to enter the name of new icons that will be created to represent the instrument settings.
- **Rename:** This button will allow the user to rename the selected icon.
- **Delete:** This button will remove the selected icon.



## Comms Tab

There are 5 Comms options: Cable, Bluetooth, Radio, Radio (Bluetooth), and USB. The Comms tab allows you to specify communication parameters. For most total stations, communication is by cable. For many newer total stations, there is a Bluetooth option. The user can detect if there is any Bluetooth emulated serial COM port available by looking for the Bluetooth icon or application. Typically, COM 1 and COM 2 are reserved for serial cable connection, so Windows Mobile will use higher COM ports to emulate the connection by Bluetooth. It is recommended to choose COM4 or higher for the Bluetooth COM port. This is done outside of SurvPC, using features of the Windows Mobile device. If the Generic Bluetooth method is selected, then the user can choose the COM port for Bluetooth as prompted within SurvPC. SurvPC can use Bluetooth to communicate only with instruments that have Bluetooth capability. Some total stations have Bluetooth passwords (PIN #) such as "0000". The user can find the Bluetooth device and can change the name and the password for the Bluetooth present on the instrument by using the "Bluetooth Settings" button (the tool icon). In many commands, such as Store Points and Stake Points (in Surv Menu), there is a Bluetooth "Reconnect" option found under the Helmet icon (upper left), for quick reconnection if Bluetooth linkage is lost. For robotic total stations, there may be a Radio option that resembles the Cable option, except that an extensive list of radio types is available.

The screenshot shows the 'Instrument Setup' dialog box with the 'Comms' tab selected. The 'Type' dropdown menu is open, showing options: Cable, Cable, Bluetooth (highlighted), Radio, and Radio (Bluetooth). The 'Port' is set to 'COM 1'. The 'Baud' rate is '115200', 'Parity' is 'None', 'Data Bits' is '8', and 'Stop Bits' is '1'. There is a 'Defaults' button on the right.

The screenshot shows the 'Instrument Setup' dialog box with the 'Comms' tab selected. The 'Type' dropdown menu is set to 'Radio'. The 'Radio' dropdown menu is open, showing 'Satel 3AS' (highlighted) and a tool icon. The 'Port' is set to 'COM 1'. The 'Baud' rate is '115200', 'Parity' is 'None', 'Data Bits' is '8', and 'Stop Bits' is '1'. There is a 'Defaults' button on the right.



- **Port Number:** You must select the COM port to use. This is the COM port of the PC.
- **Instrument (Bluetooth):** SurvPC can use Bluetooth to communicate only with instruments that have Bluetooth incorporated on them. The Instrument name is displayed when a Bluetooth connection is made.
- **Baud Rate:** Baud rate for data transfer by serial cable or radio.
- **Parity:** Parity setting is None, Odd or Even.
- **Data Bits:** You must select the character length setting.
- **Stop Bits:** You must select the stop bits setting.
- **Defaults:** Clicking Defaults will utilize the standard default settings for the configured instrument.

### Bluetooth Wireless

Bluetooth is automatically detected on the Windows Mobile PC, if available. The com port settings to use Bluetooth vary from unit to unit. For example, Com 3 is typical for the Compaq Ipaq and Com 5 is typical for the Topcon FC1000, though it may use any of Com 4, 5 or 6. On the Allegro, the Bluetooth port is typically Com 4, 5, 8 or 9. The Bluetooth serial com port settings can be found in the “My Bluetooth Device” menu selection.

### Settings/Search Tabs

The image displays two screenshots of the 'Instrument Setup' software interface. The top screenshot shows the 'Settings' tab with the following configurations: EDM Mode (Standard), FS Target (Leica 360), BS Target (Leica 360), Guidelights (Off), Guidelights Intensity (Medium), Laser Pointer (Off), and Compensator (Enable). There is also a checkbox for 'Lock in on the fly' which is unchecked. The bottom screenshot shows the 'Search' tab with the following configurations: 'Power Search' is checked, 'Joystick Speed' is set to High, 'Search On Read' is set to ATR Search, 'Horiz. Range' is 4°00'00", 'Vert. Range' is 4°00'00", 'Turn to Pt. in Stakeout Horiz.' is unchecked, and 'GPS Search' is unchecked. A 'Settings' button is visible at the bottom right of the Search tab.

- **EDM Mode:** Options may vary based on the total station selected. Note that EDM mode in these tabs refers to the reading method when using the read button within live survey screens. When the instrument is tracking and the store button is pressed, all readings will be taken at the fastest possible EDM mode.



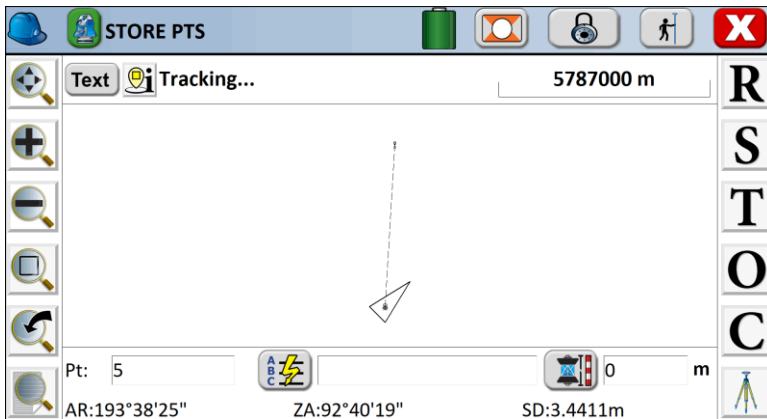

- On the Leica 1200 total stations, for example, available methods are Standard (1.5 to 2 seconds), Fast, Reflectorless, and User Defined. Referring to the graphic below, when storing points or staking points, your current mode of operation is displayed on the top line (e.g. prism mode, locked on and tracking the target, measuring distances). Clicking the "little man" or distance tracking icon takes the program to the "No Distance" or "Tracking Only Mode" (no distance measurements, locked on and tracking target). Avoiding taking distance measurements will save battery usage. On large topo jobs or as-built surveys, many field surveyors prefer to turn off distance tracking, but leave the instrument locked on the target for quick measurements. On Leica instruments, this will show a beam or line in the direction of the prism, which will move as you walk between measurements. While locked on and tracking distances (as shown below), the store icon (data collector icon) will always take a "Tracking" shot (last shot in memory) and pressing enter will take a Tracking shot if Enter is configured to Store only (to mimic the store icon). Pressing the read icon (measure icon) will always cause a new, fresh reading to be taken, as will Enter when configured to Read and Store (normal). The figure below shows the Tracking/Distance mode, which follows the movement of the prism by taking rapid distance measurements, much like RTK GPS.



Note that in the above figure we are in "Tracking/Distance" mode for display and quick readings by S. Changing to "No Dist" mode leads to display of direction only, as shown in this figure:

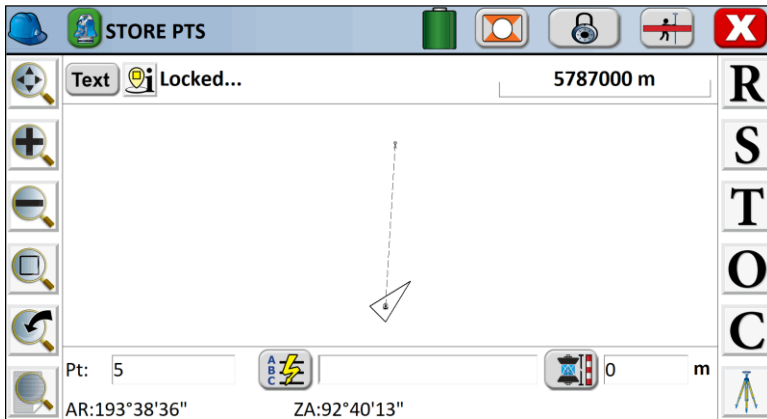



- **Foresight/Backsight Prism Offset:** This drop-down menu provides a list of standard prism offsets. Whenever a prism constant is changed, a note is written to the raw (RW5) file. When you select one of the prisms from the list (Circle, Mini, etc), the value that is shown in parenthesis is the actual value sent to the instrument. i.e. 0.0 for Circular, 17.5 for Mini. If you select "30mm" or "40mm", we send - 4.4 and 5.6 respectively (30-34.4 and 40- 34.4). The user may also type in any value they choose. In this case, we will send that value exactly, unmodified, to the instrument.
  - (360) (23.1): Prism offset of 23.1 (Leica model).
  - Circle (0.0): Standard Leica round prism.
  - Mini (17.5): Leica mini prism.
  - ReflTape (34.4): Equates to zero offset (wall, surface).
  - 30mm: Other manufactures (Sokkia, Seco).
  - 40mm: Other manufacturers.
- **Guidelights:** When available, guidelights can be turned on or off and their intensity set by the user. They are seen from the prism viewpoint, and are valuable when running robotically from the prism, looking at the instrument. The field surveyor can see when he is lined up with the instrument by the appearance of the guidelights.
- **Laser Pointer:** On  / Off  Ideal for indoor or dark evening surveying, this feature causes the instrument to emit a red beam. It is often used when doing reflectorless work and makes a red mark on the wall, floor or object being surveyed. This is useful for confirming the position prior to the shot. The beam should not be directed into someone's vision or eye.
- **Compensator:** Settings are On or Off.
- **Power Search Enabled:** The Power Search option may be available with motorized total stations. This option activates the "Power Search" button in the "banner line" at the top of the survey and stakeout screens. When Power Search is pressed, the total station will typically find the prism in 10 seconds regardless of the direction it is initially pointed. If it has found one prism and you hit "Power



Search” again, it will leave that prism and find the next one. If you have only two prisms on the job (foresight and backsight), it will conveniently rotate from the foresight to the backsight and back again each time it is pressed. An option to ignore the backsight is available as well, if preferred.

- **Use ATR:** When this feature is enabled, ATR (Auto Target Recognition) will be used when configured to standard or fast reading. When running the robotic in remote mode with ATR turned on, and when performing a “Set Angle and Read” in the backsight screen (a standard measured backsight), the ATR connection will be taken into consideration, so that the angle set is relative to the center of the prism, not necessarily the crosshairs of the instrument. The “Set Angle” and “Check Angle” functions will still be relative to the crosshairs. With ATR set on a robotic total station such as a Leica 1200, the prism can be found even if the instrument is not pointed exactly at the prism. The ATR feature is strong enough to shift the instrument onto the exact center of the prism even if sighting slightly outside the prism circle itself.
- **Horizontal Range/Vertical Range:** This is the range that will be used in a Standard Search. When lock is lost, and the "binoculars" icon appears, tapping the binoculars or "search" icon will conduct a standard search for the prism through the range of horizontal and vertical angles set, based on the current centering of the instrument. This feature applies to all robotic total stations.
- **Power Search (Work Area Settings):**

**Work Area Settings**

No window (full 360)  
 Ignore Backsight  
 Define Window

Work Area

Hz Left:	0°00'00"
Hz Right:	0°00'00"
V Upper:	0°00'00"
V Lower:	0°00'00"

Define  
Center  
Show

Min Dist: 0.0000 ft ax Dist: 0.0000 ft

### **No window (full 360):**

This will define an unlimited area for searching, allowing for a full 360-degree search area.

### **Ignore Backsight:**

This option allows for the instrument to ignore backsight when searching points in the field.

### **Define Window**

This will define a limiting area for searching. This can speed up both the standard ATR Search and the PowerSearch. The Work area angle ranges apply to both searches.



- **Show** will show the two positions of the search window, first by moving immediately to Position 1. You will be prompted to press OK to see Position 2.
- **Center** will move the search window to a new center position. You will be prompted to “Sight on Centered Position and Press OK”.
- **Define** will prompt you to shoot the lower left and upper right positions, which are then displayed above under “Work Area”. If the Work Area is set to start at 0.0000 horizontal, for example, searching would send the instrument to the backsight point.
- **Search When Lost Lock:** This feature will auto-search whenever a measurement is taken, if the instrument is not currently locked on target.
- **Turn to Point in Stakeout Horizontal/Turn in Vertical:** These options are useful only in stakeout with motorized total stations, and the effect is to turn to where the stakeout point or position is calculated to be. If Turn to Vertical is off and only Turn to Horizontal is on, the instrument will retain the current vertical position of theodolite.



## 5.2 Total Station Prism Search by GPS



This feature utilizes NMEA GPS to help the motorized or robotic total station find the prism. Often the NMEA GPS is the one built into the PC itself. For example, with the Carlson Mini2 or the Hi-Target Qmini, both of which have built-in L1 GPS, the SurvPC software can access this GPS and guide the instrument to the prism. You can also link to an external GPS like a Garmin 10, if your PC has no built-in GPS capability. This feature is not designed for full RTK GPS, but only for NMEA or any GPS sending the "GGA" message, which is typical of NMEA GPS. This feature is particularly useful with the Focus 30 robotic total station from Spectra, the Focus 10 (former Geodimeter 600 and Trimble 5600), Topcon and Sokkia robotic total stations, the Stonex R9 and even the strongest "Power Search" based robotic total stations all of which in certain situations may be interrupted by leaves, fog, reflective surfaces, even the sun in some cases. With Prism Search by GPS, the instrument turns in the direction of the GPS position and can often sight close enough to allow target recognition features to take over and locate the prism.

**Grid Coordinates and Local Coordinates: There are 3 ways for the feature to work:**

1. Fully automatic if the job is on grid coordinates, as in Job Settings, System Tab.
2. Fully automatic if the job is on local coordinates and a GPS localization file is referenced.
3. Functional after 3 points due to an internal localization and improving in accuracy until 20 total station field points are measured, after which the program statistically uses the "best" 20 points and removes outliers. Any new point is checked to see if it improves the localization by comparing total station and GPS distances. You can also block the program from considering new points for a tighter localization (such as to avoid points near canopy). The localization for Prism Search by GPS can be stored and re-used in subsequent days.

In the graphic below, GPS Search, using the NMEA GGA message built into the Mini2 PC, can be used to find the prism if there are many interfering reflecting objects in the vicinity.

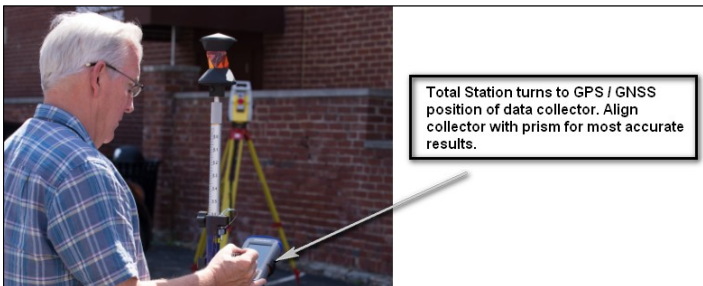



The features are found within the Search Tab for any robotic total station driver.

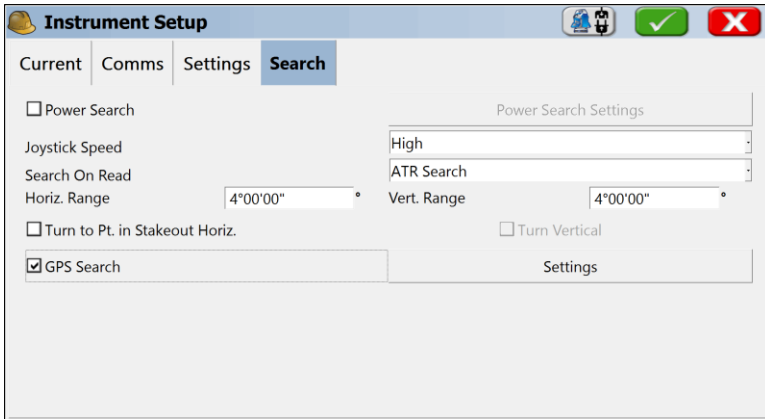

For any robotic or motorized total station, the Search tab will contain the GPS Search option. Select this and then choose Settings:

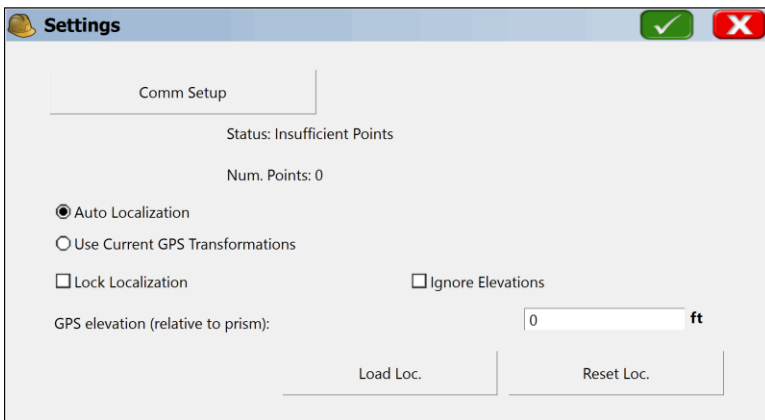

The Settings dialog shows the 3 methods of GPS Search. Method 1 is Auto Localization which uses the measured field points "on-the-fly". This is the 3rd method mentioned above, the internal localization. If you have less than 3 field measurements with total station and GPS data in common, Status will indicate "Insufficient Points". If you use Auto Localization from field measurement points, you can lock the localization and not use additional points for the calculation. You can also Ignore Elevations.

If you set "Use Current GPS Transformations", you have 2 options, to work with a loaded localization file or to use no localization file and use only the direct grid coordinates for the selected projection as configured in Job Settings, System. When an existing localization file is loaded, the geoid separation information will be compared against current user settings. Current user settings for geoid separation will override



geoid separation data in the localization file. A note regarding the change will be logged in the rw5 file. Any specified Geoid file will also be used in locating the prism from the GPS reading.

The GPS elevation (relative to prism) option allows the user to define an offset between the prism and the GPS in order to get more accurate elevations in GPS Search.

The Comm Setup option refers to the communication with your PC to obtain the NMEA GPS position. The Mini2, for example, can communicate through Com 8 at 115,200 baud based on an internal connection. You select "Cable" but it is using an internal cable to the motherboard. Clicking the GPS icon at the top of the dialog will verify the connection.

The screenshot shows a 'Configure' dialog box with the following settings:

Type:	Cable	Defaults
Port:	COM 8	Defaults
Baud:	1200	Parity: Even
Data Bits:	7	Stop Bits: Low

It should be noted that you can also use a completely external separate GPS unit for the NMEA message and link to that unit with your PC (which may lack the GPS NMEA feature). For example, a little Garmin 10 GPS can be the source of the NMEA GPS position, linked by Bluetooth to your field PC.



## 5.3 GPS Setup



Both Base and Rover GPS are configured with Receiver and RTK in the same manner. Base GPS requires additional setup and is covered in the GPS Base section. GPS Rovers section covers the configuration of GPS networks and internet corrections. This section covers the common portion of the process, selecting the GPS equipment doing basic configuration. In the dialog below, it is recommended to work left to right across the menu structure. Here are two examples (Altus and Ashtech, near the top of the alphabet). The recommended procedure is to work left to right across the tab items, from Current to RTK and then within tab options, verify the items from top to bottom. Note that configurations, including settings in Comms, Receiver and RTK tabs, can be given names, saved and recalled using the Load option.

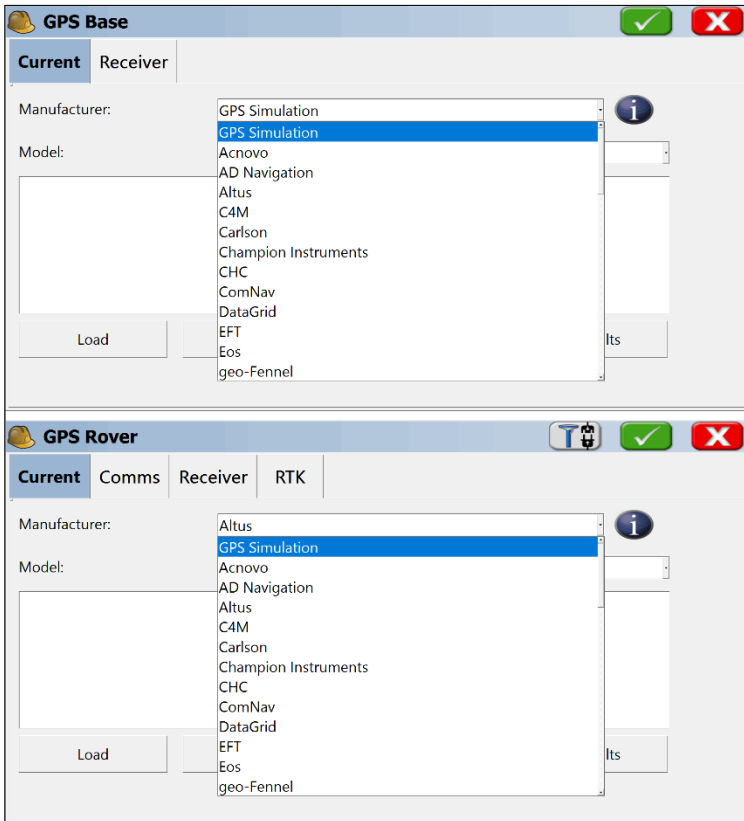



### Current Tab

Select first the manufacturer and then the model for the GPS equipment to be used. Do this distinctly in the GPS Base and GPS Rover command if different brands and models of GPS equipment are used. The blue 'i' will show receiver, IMEI, and ISDN information when possible; when this is clicked on, SurvPC will refresh the model information.

### Comms Tab

Typical connection is by cable, but in more recent GPS models, Bluetooth connection is available, for example, with Ashtech ZMax, ProMark 500, ProFlex 500, Topcon Hiper and GR3, Altus APS-3 and other models. The Bluetooth Com port comes from the PC and can be any number. In a few cases such as the Ashtech ZMax, the Bluetooth Com port should be set to the baud rate in Comms Setup to match the baud rate set for Port C on the ZMax receiver which is typically used for Bluetooth communication. For Topcon, set the baud rate in Comm Setup to match the baud rate for Port B on the Hiper receiver, which is typically used for Bluetooth.

### Find Receiver

Clicking the tools icon next to the right of Device proceeds to the Bluetooth Manager screen. This screen gives you the option to choose which GPS receiver you would like to connect to via Bluetooth. If you click Cancel, no Bluetooth connection will be established. Select a receiver and click the Bluetooth icon at the top of the screen, to connect.

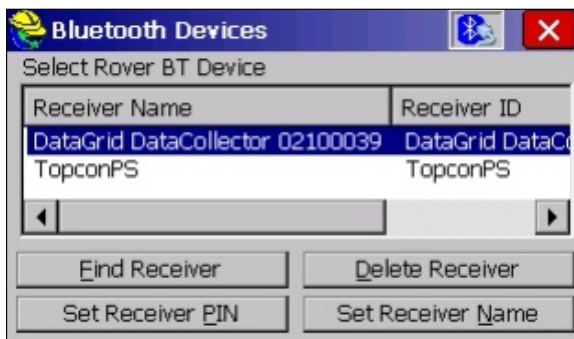

First time into this routine, no receivers will be listed. Select Find Receiver and you can add the connected receiver to the list. (You may also find ALL Bluetooth devices in the vicinity, which may include cell phones and computers.

Generally, a search window appears as shown below:



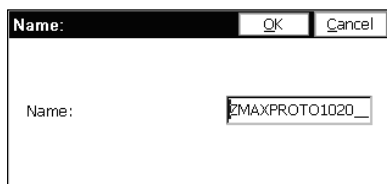
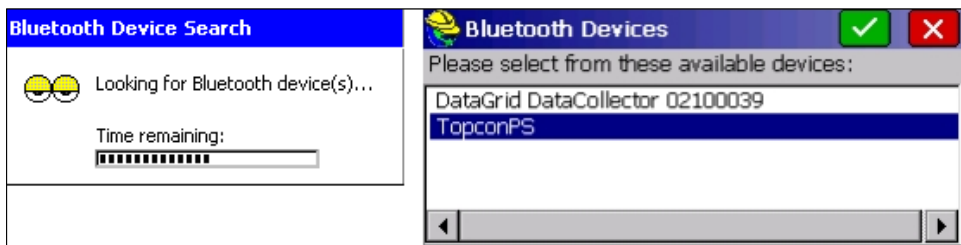

### Delete Receiver

Highlight a Bluetooth Receiver and click Delete Receiver button to remove the device. You will be prompted before removing the device.

### Set Receiver PIN

You can enter the receiver PIN by clicking “Set Receiver PIN”, and you can change the receiver name by clicking “Set Receiver Name”.

*The default PIN is different for each manufacturer and examples for PINs are below. Please see your equipment manuals for your equipment PINS.*

*Topcon 11111  
Leica 00000  
Thales 12345*

### Bluetooth Manager

The Bluetooth Manager will appear in many places: entry into the program, clicking OK from Comm Setup, Configure Base, and Configure Rover (it works the same from all of them). After making a successful connection, the software will let the user know. If the connection fails, there will be a warning.

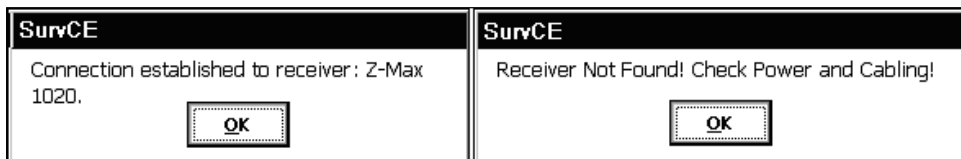

*Trouble-shooting Note: Be sure the GPS receiver is turned on before trying to connect, and that you are within 30 feet of the receiver. If the user can't see the device from the Bluetooth Devices program, it is not going to work in SurvPC. The Bluetooth Manager works somewhat better with a passkey but it is not strictly necessary. Sometimes the Bluetooth registry settings don't work correctly with an empty passkey. A pass key*



is the name the Bluetooth driver uses for a password. This is always used on Thales/Ashtech and can be used on Topcon. It makes the Bluetooth connection more reliable.

## Receiver Tab

This tab is used to Configure the receivers Antenna, set the elevation mask and for some gps position rates.

The screenshot shows the 'GPS Rover' software window with the 'Receiver' tab selected. The interface includes a title bar with a yellow bell icon, the text 'GPS Rover', and three icons: a blue 'T' with a hand, a green checkmark, and a red 'X'. Below the title bar are four tabs: 'Current', 'Comms', 'Receiver' (highlighted), and 'RTK'. The main area contains several settings:

- Antenna Type:** A dropdown menu showing '[HEMS321 NONE] Integrated G' with a 'List' button (blue 'T' icon) to its right. To the right of the dropdown are two radio buttons: 'Vert' (selected) and 'Slant'.
- Antenna Height:** A text input field containing '0' followed by the unit 'ft'. To the right, it says 'Abs. 131.9mm'.
- Elevation Mask:** A text input field containing '10'.
- Position Rate:** A dropdown menu showing '1 Hz'.
- Use IMU:** An unchecked checkbox.
- Audio Mode:** A dropdown menu showing 'On'.
- Advanced:** A button located at the bottom right of the settings area.

- **Receiver Model:** SurvPC will auto-detect the receiver model and display it in this list. It will also auto-detect the port setting for data and the port baud.
- **Antenna Type:** The entire list of NGS supported antennas is available for selection. To select an antenna, press the "List" button and search the list by manufacturer. In this dialog, the user can also verify the antenna offset values or create custom antenna types.
- **Antenna Height:** Entered as either "vertical" or "slant" height in the current job units. The slant height is the distance from the base of the pole or from the "hub and tack" up to a mark or defined slant measurement point on the edge of the antenna (See NGS for more details). The vertical height is measured plumb, straight down from the base (where it screws into the antenna) of the antenna to the ground.
- **Use Internal Antenna:** Many GPS units now have internal antennas. Select this option if not using an external antenna.
- **Elevation Mask:** This specifies the cutoff vertical angle above the horizon. Any satellites below this angle will be left out of calculations.
- **Position Update Rate:** This option allows the user to set the position update rate for the GPS readings. 1 Hz will display one reading per second, while 5 Hz is 5 times per second.
- **Use IMU:** This option utilizes the IMU on the internal GNSS Receiver, if applicable for that model. Here, using a Carlson BRx6 the option is available.
- **Advanced:** This option will allow the user to:
  - Tag Stored Points in Log File using a given duration. SurvPC will ask the user to open a log file if one is not already open.



- Configure Constellations (SBAS, BeiDou, Galileo, GLONASS – shown below)
- Enable / Disable SureFix, if available.
- Send a selected file after configuration is completed
- Configure NMEA output (Varying options depending on the receiver type – Carlson BRx6 shown below)

**Advanced** [✓] [X]

Log Raw Data to Receiver

Readings Per Point:

Send file after config

**Configure NMEA Output**

---

**Configure NMEA Output** [✓] [X]

GGA	OFF
GLL	OFF
GSV	OFF
GSA	OFF
ZDA	OFF
LLQ	OFF



**Advanced** [checkmark] [X]

Log Raw Data to Receiver

Readings Per Point:

Send file after config 

**Advanced** [checkmark] [X]

Use GPS

Use QZSS

Use SBAS (WAAS,EGNOS,etc.)

Use Beidou

Use GLONASS

Use Galileo



## RTK Tab

The RTK tab is used to configure the GPS RTK communications.

The screenshot shows the 'GPS Rover' application window with the 'RTK' tab selected. The interface includes the following fields and controls:

- Device:** A dropdown menu currently showing 'Cable or Generic Device'.
- Network:** A dropdown menu currently showing 'None'.
- RTK Port:** A dropdown menu currently showing 'COM 1'.
- Baud:** A dropdown menu currently showing '115200'.
- Message Type:** A dropdown menu currently showing 'Auto'.
- Base ID (0-1023):** An empty text input field.
- Use Any Base ID:** A checked checkbox.

- **Device:** This list contains the supported devices that deliver or receive RTK messages, such as a radio or IP modem. If an External Radio is selected, the user will need to specify the Port, Baud, Parity and Stop Bits that the radio manufacturer requires. For internal radios, SurvPC will detect the proper settings.
- **Network:** This list allows you to configure and connect to various networks (e.g. NTRIP).
- **Message Type:** You must select the RTK message type that you wish to broadcast and receive. This is the format of the RTK message that is either sent from the base and received by the rover.
- **Base ID:** This is typically used to isolate paired devices. The user specifies that the base is "ID 1", then the rover should be set to only listen for "ID 1" so that other base stations that might be in the area do not interfere.
- **Send Rover Position to Network:** This will output a NMEA GGA message for NTRIP networks that require it – This is located in the configure menu when the **Device** is Internal GSM.



**Listen – Listen:** Listen – Listen is an RTK mode where the base sends RTK corrections to an online server via IP. The rover(s) will then connect to this online server via IP to obtain RTK corrections in the field. Both the base and rover(s) must have valid SIM cards installed and Listen – Listen service enabled. Please contact your local sales representative if you are interested in more information. Some receivers are capable of the Carlson Listen – Listen mode, notably the Carlson BRx6.

**Base Setup:** The base receiver can be setup easily in the Equip – GPS Base screen, under the RTK tab. Select Internal GSM for the device, Listen – Listen for the network, and preferred Message Type. Click on the Configuration ICON to the right of Listen – Listen to configure the IP Port and Message Type as shown below.

The image shows two overlapping software windows. The top window is titled "GPS Base" and has tabs for "Current", "Comms", "Receiver", and "RTK". The "RTK" tab is active. It contains the following fields:

- Device: Internal GSM
- Network: Listen-Listen
- RTK Port: Internal
- Baud: 115200
- Message Type: RTCM V3.0
- Listen-Listen: Listen-Listen

Each dropdown menu has a small gear icon to its right. The bottom window is titled "Configure Listen-Listen" and contains the following fields:

- Name: Listen-Listen
- Port: 0
- RTK Message Type: RTCM V3.0

Both windows have a green checkmark icon and a red 'X' icon in the top right corner.



**Rover Setup:** The rover receiver can be setup in a similar fashion. Select Internal GSM for the device, Listen – Listen for network, and Message Type (same as base setup). Click on the Configuration ICON to the right of Listen – Listen to configure the proper IP Port and Message Type as shown below.

The image shows two overlapping windows from the 'GPS Rover' software. The top window is titled 'GPS Rover' and has tabs for 'Current', 'Comms', 'Receiver', and 'RTK'. The 'RTK' tab is active. It contains the following fields:

- Device: Internal GSM
- Network: Listen-Listen
- RTK Port: Internal
- Baud: 115200
- Message Type: RTCM V3.0
- Listen-Listen: Listen-Listen

The bottom window is titled 'Configure Listen-Listen' and contains the following fields:

- Name: Listen-Listen
- Port: 0
- RTK Message Type: RTCM V3.0



## 5.4 GPS Base



For GPS equipment, it is necessary to set up the base antenna and record the correct antenna height, the antenna type (for certain equipment), and the methods used for localizing (obtaining the desired coordinates).

Much of GPS Base is common to most instruments. For example, the Base Ant. Height would be entered in feet or meters, depending on the setting specified in Units within Job Settings. Vertical or Slant height refers to the method used to measure the height of the base antenna. Vertical refers to the distance from the ground point to the antenna disk, measured plumb. Slant refers to the distance from the edge of the antenna disk down to the ground point directly beneath the center of the antenna. Elevation Mask refers to the degrees above the horizon above which satellites will be used for GPS “correction” calculations, and below which satellites will be ignored. Keep in mind that it is not always better to lower the elevation mask below 10 or 15 degrees. Satellites closer to the horizon than 10 degrees will often degrade the calculation of coordinates.

The “alternative” to GPS Base is GPS Rover. GPS receivers can usually function as either type, but must be “configured” for the role they will serve. You will be warned when you switch receiver configuration from Base to Rover and vice versa, to confirm that is what is intended.







With all RTK GPS Equipment selections (except GPS Simulation), GPS Base will first bring up settings and then proceed to the 6-option GPS Base screen which “locates” the base position.

After completing the GPS communications setup and clicking on the Ok button the Base Configure dialog will be presented. These button options ‘locates’ the base position. The 6-button GPS Base options (3 buttons per “tab”), common to all, are discussed first, followed by equipment-specific settings.

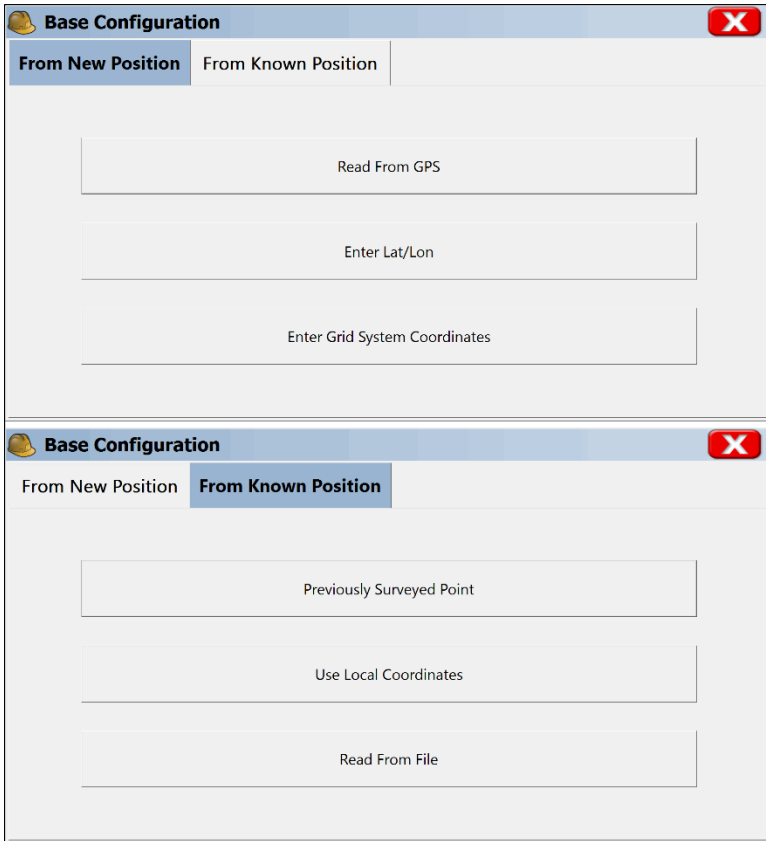



## GPS Base for All RTK GPS Brands

For all brands of GPS, the GPS Base button is the command that configures the base receiver for broadcasting GPS corrections to the rover. You must click the GPS Base button in while you are connected to the base receiver. The base needs a set of coordinates to use as its stationary position. Given that you are configured for a particular coordinate system, there are 2 main “types” of localizations: (1) Enter an Accurate Base Position and work from that point outward on the scale and “true north” of that system (no rover localization), (2) Enter an Accurate or Semi-Accurate (Read from GPS) Base Position and then localize to known rover points that transform to the local coordinate system (required if the local system is not true GPS north). There is also a “mixed” base-rover approach. To use the base in the localization, you should configure the base with the "Use Local Coordinates" option under "From Known Position". Here, you configure the base by entering the local point (5000, 5000,100) and start a new localization file (or use an existing one if it applies). Then, at your rover, you can add more points to the localization as necessary. In this case, a single rover point within Localization will produce a scale factor and best fit to the local coordinates.

There are six methods to set the stationary base position, organized into 2 categories:

### **From New Position** includes

- Read from GPS
- Enter Lat/Long
- Enter Grid System Coordinates.

### **From Known Position** includes

- Previously Surveyed Point
- Use Local Coordinates
- Read From File

When you are starting a new job (no information in the raw RW5 file yet), always use the options in From New Position.



## From New Position Options

- **Read from GPS** - This method takes a specified number of GPS readings from the base receiver's autonomous position and uses it as its "true" position. The autonomous position can be off of the actual position by 150 feet. The base will calculate corrections based on this autonomous position. If you set up the base with this method, the rover points must be used for localization since the corrections they are using are based on the approximate position of the base antenna. Read GPS, combined with rover-based localization, is one of the most common methods used to start a GPS survey. When Read from GPS is used, the program will present the current position, as shown:

The screenshot shows two stacked dialog boxes. The top dialog, titled "Average GPS", has a green checkmark icon and a red X icon in the top right corner. It contains two radio buttons: "By Number" (selected) and "By Time in minutes". To the right of "By Number" is a text input field containing "10". To the right of "By Time in minutes" is a text input field containing "30.000". Below these fields is a "GPS Monitor" button. The bottom dialog, titled "Base Configuration", contains the following fields: "RTK Broadcast ID:" with a text input field containing "17"; "Latitude: N 38°38'51.72905°"; "Longitude: W 83°45'44.07875°"; and "Ellipsoid Height: 397.2847ft". Below these fields is a "Store in Point List" button. At the bottom of the dialog is the question "Continue with Base Setup?" with "Yes" and "No" buttons.

After the Average GPS routine, the user is presented with a results dialog. Here the user can enter in a Broadcast ID (used for rovers to verify correction stream), store base point in point list, and continue with Base Setup. Answering Yes to the 'Continue with Base Setup' query will bring up an entry screen for the reference file name. Reference files are stored with a ".ref" extension. It is important to save a reference file if you plan to return to the job at another date. Without re-localizing to control points, you can set up over the same base position, recall the reference file, and enter the new antenna height for the base position, and start working.

The Read from GPS option is sometimes referred to as "Find Me". This option is accurate to Autonomous specifications, and it enables the corrections to broadcast with enough accuracy to permit localization and sub-centimeter real-time work. Be sure that your GPS zone in Job Settings is set correctly before using this option. Also, give the base enough time to find itself. When first set up, the base receiver has to "collect" satellites and "resolve ambiguities". If you Read from GPS too early, you may find a



position, but one that is not fully resolved and ends up slowing down the speed at which the rover fixes.

- **Enter Lat/Lon** - Requires you to enter the latitude and longitude for the position of the base antenna. This is useful if you are setting up over a monument whose latitude and longitude is known. It can also be used over a control point whose position is known from GPS post-processing. This will put you on the NAD83, NAD27, UTM or other coordinate system specified in Job Settings, GPS Tab. You can still do a rover-based alignment to transform to a local system. Rover-based localizations are always improved by more accurate base positioning. If the GPS detects that your entered Lat/Long is not near the current GPS readings, the program will warn the user.

Use dd.mmssss format.

Latitude: N 42°21'41.76909"

North  South

Longitude: W 71°09'53.44863"

West  East

Height: 33 ft

Ellipsoid  Orthometric

This method should be used if you are reasonably sure of the accuracy of the latitude and longitude—it should be at least as accurate as the “Read from GPS” option, or otherwise you will have difficulty getting a “fix” on the rover. If it is a very accurate latitude and longitude, you will get the best results. Pressing OK leads to the option of store the base position as a reference file, similar to Read from GPS.

- **Enter Grid System Coordinates:** Requires you to enter the grid system northing and easting for the point that the base is occupying. This applies to any projection that you have configured, including U.S. state plane, worldwide UTM or any individual country or user-defined grid system. This is useful if you are setting up over a monument whose coordinates you know. An accurate base position, either by entry of Lat/Long or Grid System Coordinates, will enable immediate data collection without rover-based localization, but also will improve rover-based localization.



**Grid Coordinate** ✓ ✕

Point From File:  ☰ 📍

KY North

Northing:  ft

Easting:  ft

Elevation:  ft

Ellipsoid  Orthometric

---

**Point Details** ☰ 📍 ✓ ⏪

Point ID	Northing(ft)	Easting(ft)	Elevation(ft)	Description	Point ID
1	5002.26	5000.06	397.308	bld	1
2	5002.18	5025.49	397.285	bld	2
3	5027.33	5000.83	397.292	bld	3
4	5027.85	5025.82	397.288	bld clo	4
5	5015.57	5151.01	397.297	bld	5
6	5015.57	5169.75	397.292	bld	6
7	5033.84	5170.64	397.297	bld rect	7
8	5034.50	5198.29	397.306	bld	8
9	5034.63	5224.60	397.306	bld rect25	9
10	5007.46	5501.79	397.286	tr oh-5 oh-12.5 oh-17.5	10
11	5006.28	5513.80	397.303	tr	11
12	5004.77	5529.23	397.292	tr	12
13	5003.32	5544.02	397.304	tr	13
14	5001.93	5558.17	397.288	tr	14
15	5000.26	5574.24	397.297	tr	15

The Coordinate method is similar to the Lat/Lon method, since Lat/Longs convert to Grid Coordinates based on the current coordinate system set in Job Settings, GPS option. The Grid Coordinates will convert back to the Lat/Long coordinates needed by SurvPC to configure the base.



## From Known Position Options

- **Previously Surveyed Point:** This requires you to enter the coordinates, on the configured coordinate system, of a known, surveyed point. This will transform and localize to the local coordinate system, and optionally can be followed by rover-based localization. The known point must be found in the RW5 file in a form that includes its Lat/Long (a previous GPS measurement). This Lat/Long, just as with New Position options, is used to establish the base position. This method requires that you are working within an existing job that has a raw file including Lat/Long positions for the points being used. This next figure is an example of the prompting.

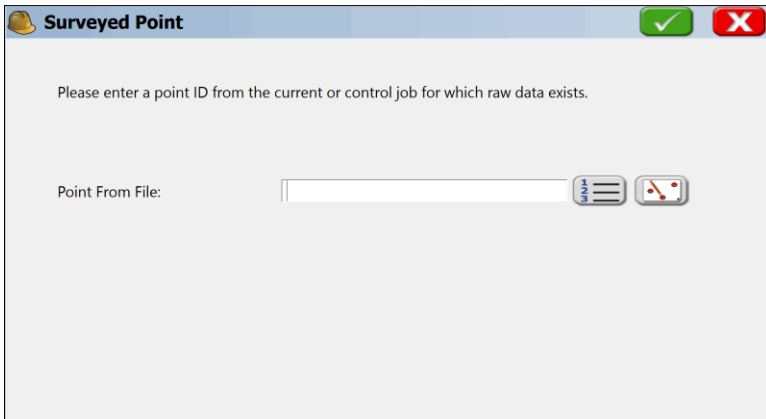

Like the other options, this continues on by showing the corresponding Lat/Long for the coordinate and allowing the user to save the result in a reference file.

- **Use Local Coordinates:** If you have “localized” using option 5 (Localization) within the Equip menu, you obtain a “dat” file. This localization file is used to convert any Lat/Long reading into a local coordinate. By the same token, you can take a local coordinate, run it back through the dat file and obtain a Lat/Long for the base receiver setup. That is the procedure used in this option.

When OK is pressed, you will be asked to load the associated “.dat” file, in a dialog similar to below:



The image shows two overlapping software dialog boxes. The top dialog, titled "Local Point", has a blue header bar with a yellow point icon, a green checkmark, and a red X. The main area contains the text "Please enter local coordinate values. You may use a point ID from the current or control job." Below this are four input fields: "Point From File:" with a text box and a menu icon; "Local Northing:" with a text box and "ft" unit; "Local Easting:" with a text box and "ft" unit; and "Local Elevation:" with a text box and "ft" unit. The bottom dialog, titled "Localization File", also has a blue header bar with a yellow point icon, a green checkmark, and a red X. It features a "Type:" dropdown set to "LOC Files" and a "Drive:" dropdown set to "C:". Below these are icons for file operations. The main area shows a file explorer view of "C:\Carlson Projects\Data\" with folders "Backup", "CSGIS", "DOTCod...", "geoids", and a selected file "DEMO.loc". The "Name:" field at the bottom contains "DEMO.loc".

- **Read From File** - Reads a previously saved base position file. All of the other methods of setting up the base let you save the base position at the end of setup. If you return to a site, set up the base in exactly the same position, use Read From File to use the same base position and you don't have to re-align the rover: the old alignment is still valid.

This option recalls a reference file in a dialog similar to that above. Then you will receive the standard prompting.



**Base Configuration**

RTK Broadcast ID:

Latitude: N 38°38'51.72905"

Longitude: W 83°45'44.07875"

Ellipsoid Height: 397.2847ft

Continue with Base Setup?

This is the Reference Station ID prompt (showing the default ID). A message is displayed after successful configuration from a file. Only if you set the base antenna on the same horizontal and vertical position each day would the base antenna height remain fixed. If the base antenna height and x,y position is the same from day to day, then you do not need to do GPS Base each day. You would simply power up the base, power up the rover and start working in that case. Keep in mind that in certain power surge conditions, receivers can lose their settings, and a re-configuration may be necessary, even if the base receiver antenna has not been moved. The option 'Store in Point List' allows the user to store the base location to the point list of the job.

If the user clicks 'OK', a notification window will be presented. This asks the user if the settings just ascertained should be saved to file. Use this option if the setup will be repeated in the future or preferred.

**SurvPC**

Base Configuration Successful. Save Settings to File?

*Note: In SurvPC 1.50.006 or later, a "quick connect" is performed when you exit and re-enter the SurvPC program. In earlier versions of SurvPC (before August 20, 2004) and after the release of SurvPC 1.50 in May, 2004, it was necessary to conduct a fresh GPS Base after exiting SurvPC.*

*Note: One method of obtaining Latitude/Longitude and state plane coordinates in the U.S. is to occupy a point, any point, for two hours or more, logging the static data, then submit the Rinex file to the NGS "OPUS" program accessible on the web. You must log the data with dual frequency equipment. The OPUS program is fully automated, and will return the x,y,z, lat, long, ellipsoidal height and orthometric height. This data can then be entered in during base localization. Though most post-processing programs (Trimble Geomatics Office, Leica SKI-Pro) use proprietary post-processing file formats, they will output the ASCII "Rinex" format needed by OPUS.*





## 5.5 GPS Rover



For many brands of GPS, receiver perform differently depending on whether they are set as base or rover. Even though the receivers are identical, they perform differently depending on whether they are configured as a base or a rover. Multiple rover receivers can communicate with a single base receiver. The GPS Rover command is used to set the rover receiver to the correct parameters and to instruct the receiver that it is, in fact, a rover.

### Connecting a GPS Rover to a Modem or Base Network

There are several methods for connecting to an available network. The RTK tab in the GPS Rover dialog configures the modems and network settings.

The screenshot shows the 'GPS Rover' dialog box with the 'RTK' tab selected. The 'Device' dropdown is set to 'Internal GSM', 'Network' is 'NTRIP', 'RTK Port' is 'Internal', and 'Baud' is '115200'. 'Message Type' is 'Auto'. The 'NtripInfoCaster' field is highlighted in blue. There are icons for help, info, and a red X in the top right corner.

The dialog is designed to be filled out from the top to bottom, and from left to right. First select the device you will use to connect to the remote modem or network.

The screenshot shows the 'Device' dropdown menu with the following options: Internal GSM, Internal UHF, Internal GSM (highlighted), Data Collector Internet, Cable or Generic Device, Satel Bluetooth, and Pacific Crest XDL BT.

If a particular receiver model supports an internal modem or radio, meaning it is integrated into the receiver; those devices are shown first in the list. When an internal device is shown in the list, it means that model could have the device inside, but does not guarantee it. The user will have to know if the receiver was purchased with an integrated radio or modem.

External radios and modems are shown next and then one of the last options is “Data Collector Internet”, which is a special case explained below where the PC provides



access to the internet instead of a modem inside the receiver or connected to the receiver.

Once a device that is capable of connecting to the internet is selected, the Network combo box is enabled. Select the type of network connection you will use.

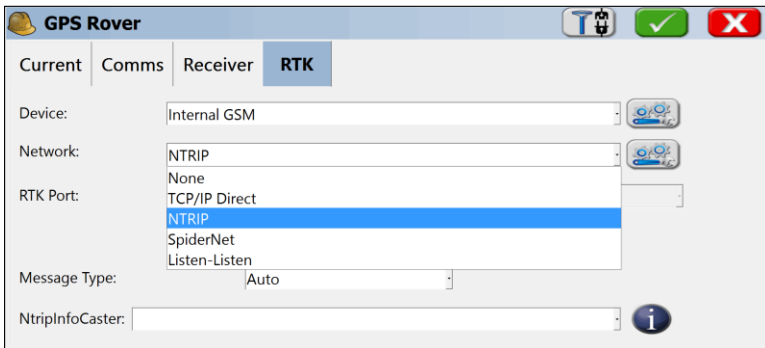

Here is a brief summary of the different network types available:

**TCP Direct:** For connecting to a single modem at a base or to a VRS network or another network that doesn't require a special login. The configure button for TCP Direct brings up this window:

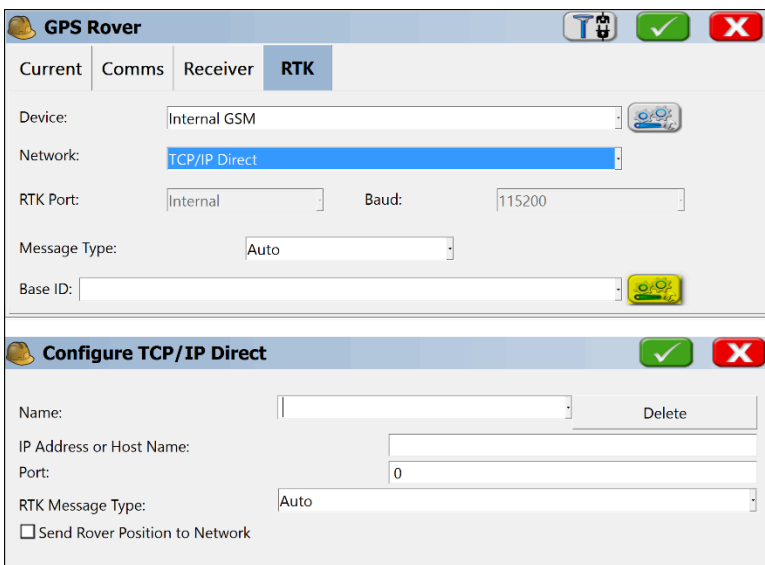



To add a new base or network address, select <New> in the Name field and replace the “<New>” text with what you want to call the connection and fill out the Address and Port fields. Most modems support either an IP address (Ex: 192.202.228.252) or a URL address (Ex: www.basenetwork.com).

**UDP Direct:** This works exactly like the TCP Direct option but uses UDP protocol instead of TCP. Most networks use TCP.

**NTRIP:** This option is for base networks that support NTRIP protocol. Pressing the Configure button shows the NTRIP Broadcasters (Also called Casters) that have been previously connected to.

The screenshot shows two windows from the 'GPS Rover' application. The top window is titled 'RTK' and has tabs for 'Current', 'Comms', 'Receiver', and 'RTK'. It contains the following fields: 'Device' (Internal GSM), 'Network' (NTRIP), 'RTK Port' (Internal), 'Baud' (115200), 'Message Type' (Auto), and 'NtripInfoCaster' (empty). The bottom window is titled 'NTRIP Broadcasters' and contains a 'Name' field (NtripInfoCaster), 'New' and 'Delete' buttons, 'IP addr' (rtcm-ntrip.org), 'Port' (2101), 'User' and 'Pwd' fields, and a 'Broadcaster Information' section with fields for Identifier, Operator, Position (0.00S 0.00W), Misc, and NMEA (Rover position not needed).

The default is for [rtcm-ntrip.org](http://rtcm-ntrip.org) which if connected to will download information about many Broadcasters (casters) all over the world. They will be shown the next time NTRIP Configure is selected. Select an existing caster or select <New> in the Name combo box and replace with a different name and fill out the other information. If the Default User and Password fields are filled out, they will be used as the default user name and password for all the bases at that caster.



When the green checkbox is selected, SurvPC will have the modem connect to the address of the Broadcaster and establish a connection. The Broadcaster then supplies a table of bases (also known as mountpoints) available at that Broadcaster. SurvPC puts the table of bases into the next window that comes up.

The image shows two screenshots of a software dialog box titled "Bases for PRSNVRSCMR".

**Top Screenshot:** The dialog box has a green checkmark icon in the top right corner. The "Name" field is set to "PRSNVRSCMR". There are "New" and "Delete" buttons to the right of the "Name" field. The "User Name" field is empty, and the "Password" field is also empty. The "Identifier" field contains "PRSNVRSCMR". The "Short Id" field contains "PRSNVRS". The "Type" field contains "GPS L1L2 Trimble GPS Net WSRN". The "Format" field contains "CMR+ 1(1), 3(10), 18(1), 19(1)". The "Position" field contains "47.68N 237.67E". The "Misc" field contains "WSRN Subnet for Puget Sound". There is an unchecked checkbox labeled "Send Rover Position to Network".

**Bottom Screenshot:** The dialog box has a green checkmark icon in the top right corner. The "Name" field is highlighted in blue, and a dropdown menu is open showing the following options: "PRSNVRSCMR", "PRSNVRSRTCM", "SWWAVRSCMR", and "NTRIP\_SKMA". The "User Name" field is empty, and the "Password" field is also empty. The "Identifier" field contains "PRSNVRSCMR". The "Short Id" field contains "PRSNVRS". The "Type" field contains "GPS L1L2 Trimble GPS Net WSRN". The "Format" field contains "CMR+ 1(1), 3(10), 18(1), 19(1)". The "Position" field contains "47.68N 237.67E". The "Misc" field contains "WSRN Subnet for Puget Sound". There is an unchecked checkbox labeled "Send Rover Position to Network".

If you don't like the name of the base supplied by the Broadcaster, you can change it to something else you prefer and SurvPC will remember your preference but still ask the Broadcaster for the correct base.



Select the base you want to use and press the green check box. You are brought back to the RTK tab with the base you selected as the current Base ID. You can change the Base ID in the RTK tab without going back to the NTRIP Configure button.

The screenshot shows the 'GPS Rover' application window with the 'RTK' tab selected. The interface includes a title bar with a user icon, the text 'GPS Rover', and three buttons: a blue 'T' button, a green checkmark button, and a red 'X' button. Below the title bar are four tabs: 'Current', 'Comms', 'Receiver', and 'RTK'. The 'RTK' tab is active and contains the following configuration fields:

- Device:** A dropdown menu showing 'Internal GSM' with a gear icon to its right.
- Network:** A dropdown menu showing 'NTRIP' with a gear icon to its right.
- RTK Port:** A dropdown menu showing 'Internal'.
- Baud:** A text input field containing '115200'.
- Message Type:** A dropdown menu showing 'CMR+'.
- PRSNVRSCMR:** An empty text input field with an information icon to its right.

Note that with NTRIP, SurvPC already knows if the base wants the rover position sent and what type of corrections are being sent. Those settings are shown in the RTK tab and are grayed out to guarantee that they stay on the correct setting.



**SpiderNet:** Networks that require that a GPUIID message be sent to the network should use the SpiderNet option. The SpiderNet Configure window comes up when the Configure button to the right of the SpiderNet option is pressed.

The image shows two overlapping windows from the 'GPS Rover' software. The top window is titled 'GPS Rover' and has tabs for 'Current', 'Comms', 'Receiver', and 'RTK'. The 'RTK' tab is active. It contains the following fields: 'Device' (Internal GSM), 'Network' (SpiderNet), 'RTK Port' (Internal), 'Baud' (115200), 'Message Type' (Auto), and 'Base ID'. A 'Configure SpiderNet' button is visible to the right of the Base ID field. The bottom window is titled 'Configure SpiderNet' and contains fields for 'Name', 'IP Address or Host Name', 'Port' (0), 'User Name', 'Password', and 'RTK Message Type' (Auto). There is a 'Delete' button next to the Name field and a checkbox labeled 'Send Rover Position to Network' at the bottom.

Add a new network by selecting <New> in the Name combo box and typing in the name of the network and filling out the other fields. If the User Name and Password fields are left empty, the GPUIID message is not sent to the network.

Just like when using a radio, the RTK Port combo box is to identify which port on the receiver should be configured to accept RTK corrections. The Baud, Parity, and Stop Bits combo boxes specify the settings for the RTK port. Message Type identifies what type of RTK correction message the receiver should be expecting.

Base ID when using a network is a combo box to select the name of the network or base the modem should connect to. Use the Network Configure button to change the bases available in this list.

“Send Rover Position to Network” if turned on will cause the receiver to periodically send GGA messages out of the RTK port to the base or network.



## Connecting a PC to the Internet

There are several ways of connecting a PC to the internet – Cell phone cards inserted into the PC, connections to a cell phone with a data plan, etc. These instructions assume that an internet connection has already been established to the PC. One way to tell that the PC is connected to the internet is to browse the internet using Internet Explorer.

Once the connection to the internet has been established, start SurvPC and select Configure Rover in the Equip tab.

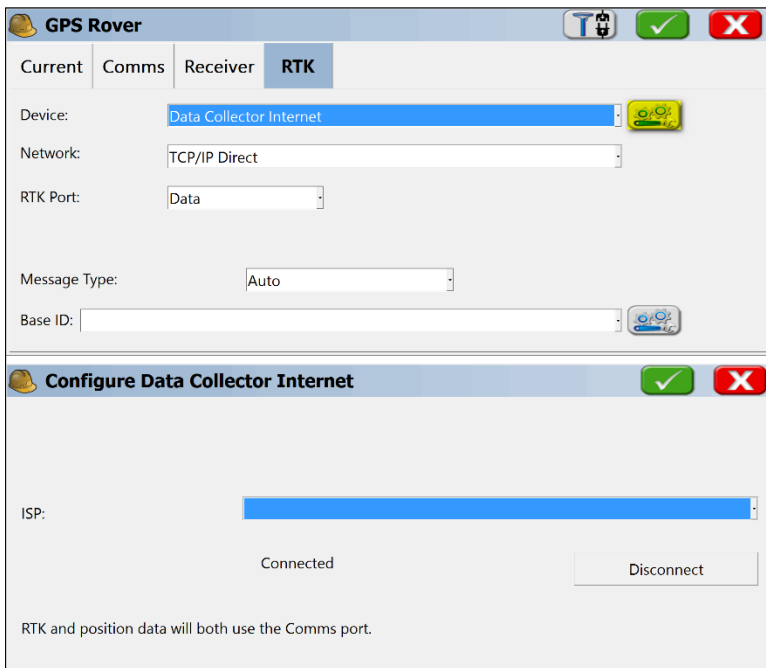

Press the Configure button to the right of the Data Collector Internet option. Select the COM port on the PC that is connected to the RTK port of the GPS rover receiver. It cannot be the same port that is used to control the receiver and is selected in the GPS Rover Comms tab. It may be a serial port or a BT port with a connection that has already been established.

After selecting the port and pressing the green check to accept the input, select the network type in the RTK tab. Other settings are just like using the other modem selections as explained in the section “Connecting a GPS Rover to a Modem or Base Network”.



## RTCM 3.1 Message String (for automated Grid Position and Geoid Adjustments)

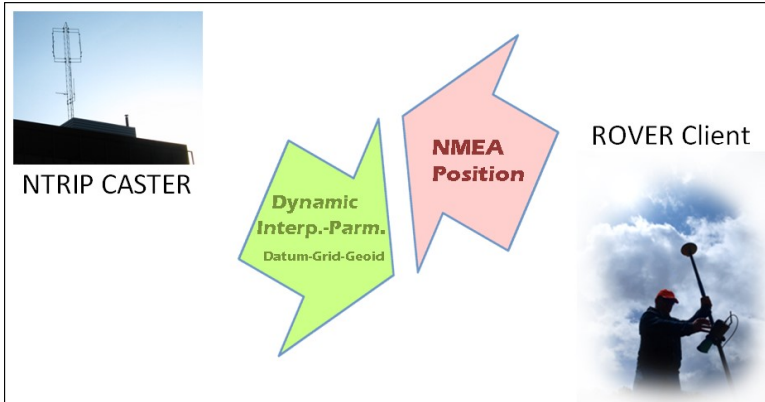

Certain NTRIP casters (virtual reference systems) send out the RTCM 3.1 message format. A subset of these casters will send out the 1021 to 1027 messages within the RTCM 3.1 formatted messages. When these 1021 to 1027 messages are available, they contain grid system adjustments, sometimes for the x,y position, and sometimes additionally for the geoidal separation or "Z" elevation adjustment. When these added messages are parsed and applied to the x,y,z position of the RTK reading, greater accuracy is obtained.

Germany, Austria and Croatia are countries where NTRIP casters adopted the RTCM 3.1 message format very early, and included the 1021-1027 message strings for x,y and z adjustments. The example below shows the sequence of operations to capture this message string as broadcast in the Bavarian region of southern Germany. First, confirm you have the correct grid system set. It is recommended not to rely fully on the RTCM 3.1 1021-1027 information for the grid source but have the correct grid zone loaded within SurvPC itself (Job Settings, System or Localization, System tab).

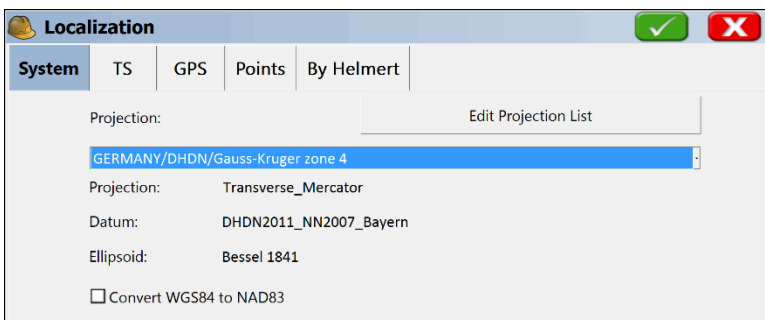





**NTRIP Broadcasters**

Name: SAPOS-BY    New    Delete

IP addr: 195.200.71.81    Port: 2101

User:    Pwd:

Broadcaster Information

Identifier:

Operator:

Position    0.005 0.00W ,

Misc:

NMEA:    Rover position not needed.

Now go to GPS Rover, RTK tab, select NTRIP for the Network, and click Configure to the right of the NTRIP option. Then load the correct network and IP Address and also enter your user name and password. The network selected above was an early adopter of RTCM 3.1 messages containing the 1021-1027 message strings. Usually you pay for access to most NTRIP service providers to obtain a user name and password.

Then when you click OK, back in the RTK tab, pick Tools/Configure opposite the Sapos-By Ntrip network and choose the appropriate mount point table or "base" that broadcasts the RTCM 3.1 message string, as confirmed in the dialog below: Note that the format is RTCM 3.1.

**Bases for SAPOS-BY**

Name: VRS\_3\_BY    New    Delete

User Name: VRS\_3\_BY    Password: \*\*\*\*\*

Identifier: VRS\_BY

Short Id: NET\_3\_BY

Type: EPS\_BY

Format: SAPOS-BY

Position: , 1005/1007/1033(10)

Misc:

Send Rover Position



**GPS Rover** [T] [GPS] [✓] [✗]

Current | Comms | Receiver | **RTK**

Device: Data Collector Internet [GPS]

Network: NTRIP [GPS]

RTK Port: Data

Message Type: RTCM V3.1  Use 1021-1027

SAPOS-BY: VRS\_3\_BY [i]

If the caster provides the RTCM 3.1 message string for 1021 to 1027, then the option "Use 1021-1027" appears. Check this on. Not every provider that offers RTCM 3.1 will support the 1021-1027 messages.

**Alert** [✓] [✗]

Projection: GERMANY/DHDN/Gauss-Kruger zone

Datum: DGND2011\_NN2007\_Bayern (RTCM 1

Horizontal Grid: SAPOS-BY\_VRS\_3\_BY\_13 (RTCM 1023

Vertical Grid: SAPOS-BY\_VRS\_3\_BY\_13 (RTCM 1023

Geoid: None

Use RTCM Projection & Horizontal Grid

Use RTCM Vertical  Reverse Vertical

Datum, Horizontal Grid, Vertical Grid will be saved as SAPOS-BY\_VRS\_3\_BY\_13



When you continue, you see this Alert screen which allows you to use selected portions of the available adjustments within the 1021-1027 message string. For example, you can choose to use both the horizontal and vertical adjustments or just the vertical to obtain the geoidal shift automatically. The "Reverse Vertical" is a rare option that applied, at least at one time, to a caster that reversed the sign on the geoidal shift. Rather than adding the geoidal shift, it would subtract it. Also, note that if you turn off the horizontal grid adjustment, then the program would revert to your Job Settings, System tab setting for the grid zone, which is why setting that zone initially is important. Where 1021-1027 message data is loaded, and imported by the above method, it is referenced in the software in other commands. For example, using another German NTRIP mount point as shown below, the 1021-1027 data are imported directly into the geoid file selection and Position tab information in Monitor/Skyplot.

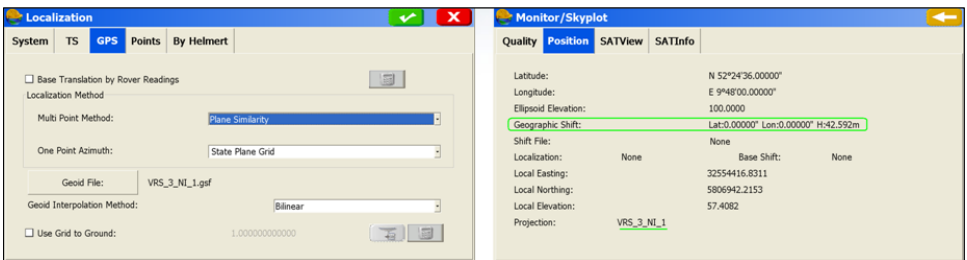

Here is another example of use of the RTCM 3.1 1021-1027 message string applying to Croatia:

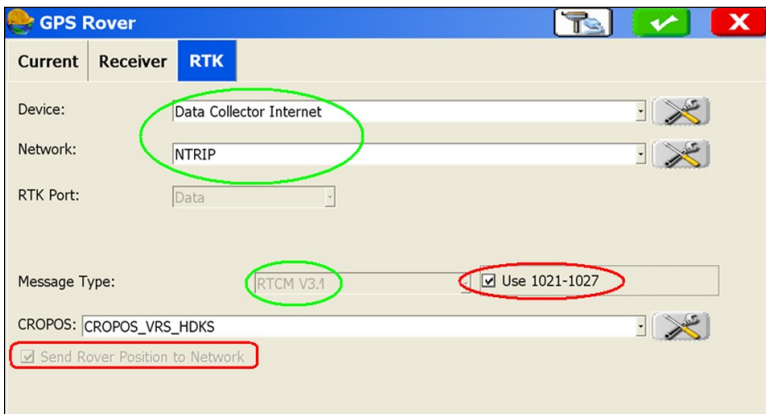



The screenshot displays two windows from a software application. The 'Localization' window on the left has tabs for System, TS, GPS, Points, and By Helmert. The 'GPS' tab is active, showing options for Base Translation by Rover Readings, Localization Method (Plane Similarity), One Point Azimuth (State Plane Grid), Geoid File (CROPOS\_VRS\_HDKS\_2.gsf), Geoid Interpolation Method (Bilinear), and Use Grid to Ground. The 'Monitor/Skyplot' window on the right has tabs for Quality, Position, SATView, and SATInfo. The 'Position' tab is active, displaying coordinates: Latitude (N 45°45'30.00060"), Longitude (E 15°54'19.99800"), Ellipsoid Elevation (100.00000), Geographic Shift (Lat:0.01127" Lon:-0.00975" H:45.374m), Shift File (C:\Sur\_0831\_1021-1023\_Testing\CROPOS\_VRS\_HDKS\_2), Localization (None), Base Shift (None), Local Easting (5570815.9329), Local Northing (5068633.1943), Local Elevation (54.6260), and Projection (CROPOS\_VRS\_HDKS\_2).

Current implementation in SurvPC is based in a new RTCM decoder that is compatible with the following RTK methods and devices:

- Any GNSS receiver compatible with SurvPC DCI (Data Collector Internet) RTK method. This mean for those able to make an NTRIP connection using a network device in the PC, like internal GPRS modem, Ethernet, WiFi, etc
- Using the Internal GSM Modem in ALTUS APS 3 or PENTAX SMT888 (both on v2 versions) GNSS rover receivers
- Using the Internal GSM modem in Stonex S8 and S9III receivers

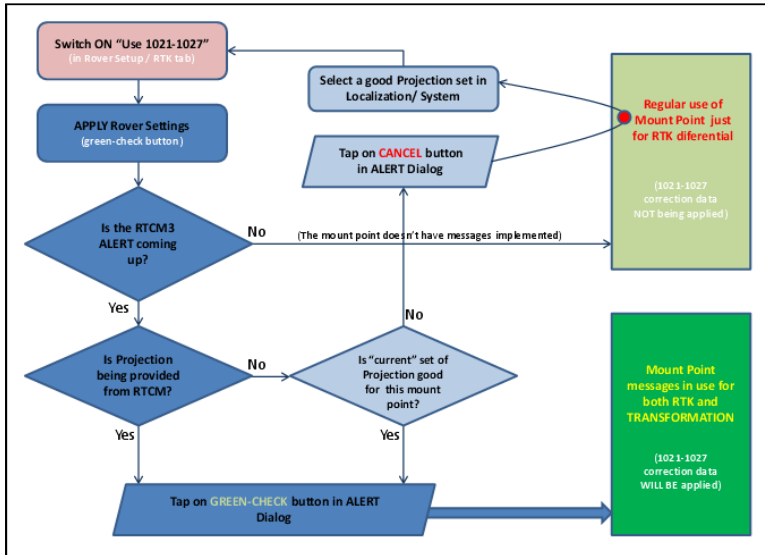



### Output NMEA to a Virtual COM Port:

For users who wish to use the NMEA output of their GNSS in another software on the same device, SurvPC can now create and output NMEA data to a virtual com port to the PC.

**Configure**

Type: Virtual COM

Port: COM3 Defaults

Baud: 9600 Parity: None

Data Bits: 8 Stop Bits: 1

Under Equip→GPS Rover→Advanced, select ‘Configure NMEA Output’. Enable ‘Log to DC Port’ and press the Comm Setup button, then select ‘Virtual COM’ from the drop-down menu. The port selected can then be opened and read by a secondary program on the same device.



## 5.6 GPS Raw Only



GPS Raw Only allows the user to configure the receiver to log data internally. This data can be used in post-processing applications. There are three logging methods of GPS Raw Only:

- **Static:** This method assumes the logging receiver will not be moving (static) during the GPS Raw Only dataset.
- **Stop and Go:** The method assumes the logging receiver will be moving and storing points (stop and go) during the GPS Raw Only dataset.
- **Fully Kinematic:** This method assumes the logging receiver will be moving continuously (fully kinematic) during the GPS Raw Only dataset.

Once one of these methods is configured, the operation mode will update to show GPS Raw Only is active. In the top bar of the Menu screen(s), the GPS Raw Only Icon will appear.



The GPS Raw Only mode can be excited by switching mode within the Quick switch dropdown.

### GPS Raw Only – Static Logging

Static logging is categorized as a GPS Base option. Thus, this option can be initialized by either the GPS Raw Only or GPS Base routines. The GPS Raw Only routine allows the user to tag a point.

- *Equip – GPS Raw Only – Settings tab – Static selection*
- *Equip – GPS Base – Advanced – Enable Log Raw Data to Receiver*

Certain parameters are assumed when initiating the command via the GPS Base routine, such as logging interval, and stationary as the logging method. Using either routine to initiate the command will navigate the user to the Log Raw Data File screen.

The screenshot shows a screen titled "Log Raw Data File" with a blue header bar. On the right side of the header are three icons: a back arrow, a green checkmark, and a red X. Below the header, the text "Free Memory: 884.94Mbytes" is displayed. There are four rows of configuration options:

<input checked="" type="checkbox"/> New File:	Newer_File
<input type="checkbox"/> Existing:	New_File.log
Antenna Height:	2 m
Observer ID:	Peter

In the Log Raw Data File screen, the user may start a new log file or append an existing log file. The above image is attained through *Equip – GPS Raw Only – Settings tab –*



*Static selection*, where the user may select data logging parameters in the Settings tab. Alternatively, the user may initiate data logging through *Equip – GPS Base – Advanced – Enable Log Raw Data to Receiver*. The GPS Base setup routine will allow users to select data logging parameters (receiver specific) from the Log Raw Data File screen, thus a settings icon is shown in place of the back arrow and opens the Raw Data Settings screen (shown below).

**Log Raw Data File** [Settings] [Check] [X]

Free Memory: 1.0183Gbytes

New File: Newer\_File

Existing: New\_File.log

Antenna Height: 2 m

Observer ID: Peter

---

**Settings** [Check] [X]

Log Interval: 1.00 seconds

Include diagnostic data

*Note: Options available on the Start New File screen will be receiver – specific.*

The Antenna Height and Observer ID may be set from this screen as well. The Log Raw Data File screen allows for the initial parameters of the log file to be activated. Clicking on the Back arrow will go back one screen (Equip – GPS Raw Only). Clicking on the Settings Icon will open the Raw Data Settings screen (Equip – GPS Base). Clicking on the Red ‘X’ will exit out of the logging routine. Clicking on the Green check will:

- Activate the logging file (Equip – GPS Base).
- Activate the logging file and continue to the Tag New Site screen (Equip – GPS Raw Only).

**Tag New Site** [Check] [X]

Free Mem on Receiver: 1.5037Gbytes

File: Newer\_File.log

Site Name: Test1

Close Site Tag:

Manually  After 1.00 minutes

The Tag New Site screen allows for a Site Name to be entered as well as options for how and when to close the Site tag.

*Note: Closing the Site Tag will not close or stop the logging file.*



Clicking on the Red 'X' will exit the logging command. Clicking on the Green check will continue to the Recording Site screen. We have named our Site Name 'Test1' and selected the Site Tag to be closed in 1 minute.

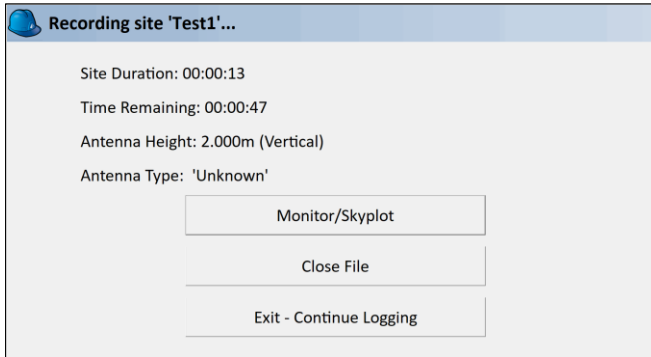

The Recording site 'XXXX' screen allows the user to see the current status of the logging file.

The Monitor Skyplot button will allow monitoring options during the logging period. The Site Duration and Time Remaining will show on the top bar of Monitor Skyplot screens.

Site Duration: 00:00:34 Time Remaining: 00:00:26

Quality	Position	SATView	SATInfo
Status:	FIXED	Satellites:	16/17
Latency:	N/A	Local Elev:	97.9911m
Local Northing:	4281256.4530m		05/10/2018
Local Easting:	259538.0724m		09:41:08.1
HDOP:	1.10	VDOP:	2.10
TDOP:	2.00	PDOP:	2.37
GDOP:	3.10		
HRMS:	0.016m		
VRMS:	0.031m		

The Close File button will allow the user to close the file immediately. This will prompt the user with a confirmation screen to confirm closing the log file is the preferred operation.



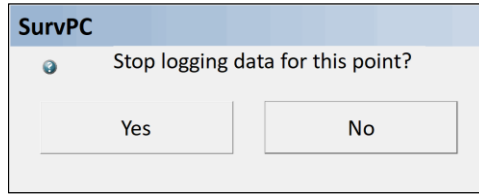

If either the Yes button in the Stop logging data for this point confirmation window or the file completes, the user will see a logging complete notification screen.

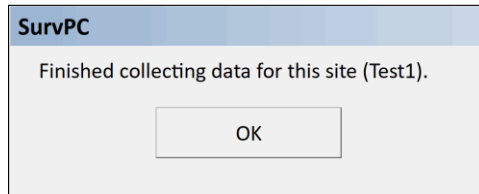

By clicking the OK button, the user has finished collecting data for the site.

The Exit – Continue Logging button will allow for the user to disconnect from the receiver.

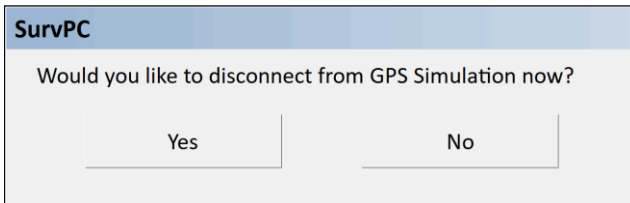

This allows for data logging to be setup on multiple receivers simultaneously. Note however, that logging cannot be stopped automatically when disconnected from the receiver. To stop data logging when using several receivers, a reconnection needs to be made and the close file command ran (Equip – GPS Raw Utilities – Close File).

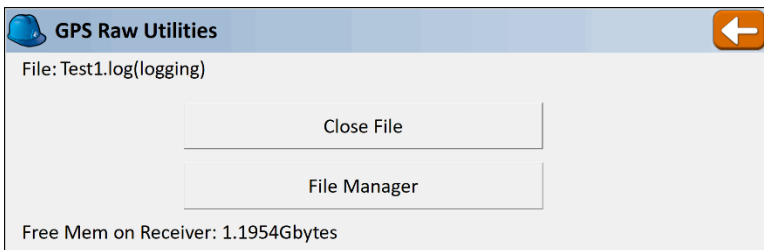



## GPS Raw Only – Stop and Go Logging

Stop and Go logging is categorized as a GPS Rover option. Thus, this option can be initialized by either the GPS Raw Only or GPS Rover routines. The GPS Raw Only method allows the user to tag points right away by taking the user directly to the Store PTS screen.

- *Equip – GPS Raw Only – Settings tab – Stop & Go selection*
- *Equip – GPS Rover – Advanced – Enable Log Raw Data to Receiver*

Certain parameters are assumed when initiating the command via the GPS Rover routine, such as logging interval, and stop and go as the logging method.

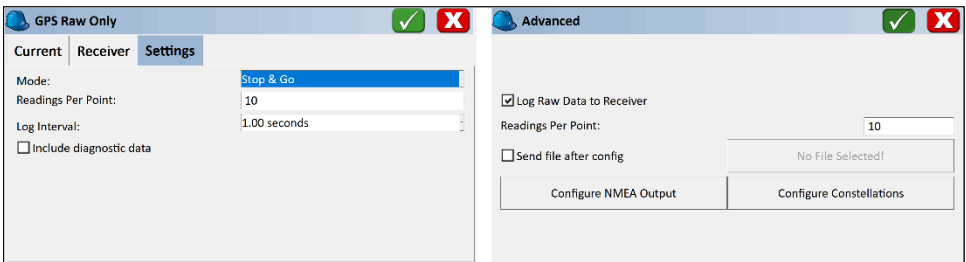

Reading Per Point is an option allowing the user to select the number of readings to average prior to storing a point. The selection made here (10 in our example) will be part of the GPS Raw Only profile. The number selected for in the GPS Raw Only profile for Reading Per Point will override any setting within the Store Point configuration routine.

Using either routine (GPS Raw Only or GPS Rover) to initiate the command will navigate the user to the Log Raw Data File screen.

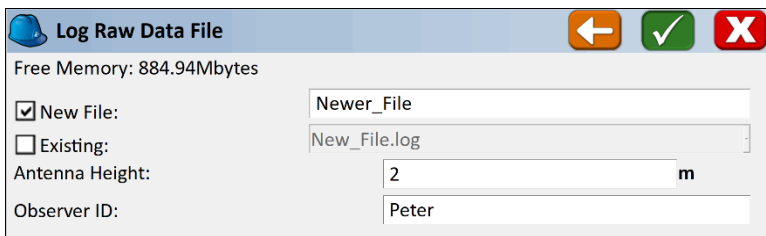

In the Log Raw Data File screen, the user may start a new log file or append an existing log file. The above image is attained through *Equip – GPS Raw Only – Settings tab – Stop and Go selection*, where the user may select data logging parameters in the Settings tab. Alternatively, the user may initiate data logging through *Equip – GPS Rover – Advanced – Enable Log Raw Data to Receiver*. The GPS Rover setup routine will allow users to select data logging parameters (receiver specific) from the Log Raw Data File screen, thus a settings icon is shown in place of the back arrow and opens the Raw Data Settings screen (shown below).



**Log Raw Data File**

Free Memory: 1.0183Gbytes

New File:

Existing:

Antenna Height:  m

Observer ID:

---

**Settings**

Log Interval:

Include diagnostic data

*Note: Options available on the Start New File screen will be receiver – specific.*

The Antenna Height and Observer ID may be set from this screen as well. The Start New File screen allows for the initial parameters of the log file to be activated. Clicking on the Back arrow will go back one screen (Equip - GPS Raw Only). Clicking on the Settings Icon will open the GPS Raw Only Settings screen (Equip - GPS Rover). Clicking on the Red 'X' will exit out of the logging routine. Clicking on the Green check will:

- Activate the Logging File (Equip – GPS Rover).
- Activate the Logging File and Continue to the Store PTS screen (Equip – GPS Raw Only).

**STORE PTS**

16/19

Pt:  GPS Raw Only Point 100  m

N:4281316.7983m E:259539.8764m Z:97.9952m

HRMS:0.019m VRMS:0.035m PDOP:2.37 GDOP:3.10 TDOP:2.00

Storing a point will automatically set the user to the Average screen where the Readings Per Point will be initiated and averaged.



An Average Results screen will appear when complete.

The screenshot shows two overlapping windows from a software application. The left window, titled "Average GPS", displays the following information: "Taking Reading #4 of 10", "4 Valid readings recorded.", "SD.North: 0.0061", "SD.East: 0.0039", "SD.Elev: 0.0045", "SATS:16/17 STATUS:FIXED", and "HRMS:0.015m VRMS:0.037m". At the bottom are two buttons: "Stop Averaging and Store" and "Cancel Averaging". The right window, titled "Average Results", has a green checkmark and a red 'X' in the top right corner. It shows "Valid Readings: 10/10" and "Fixed: 10/10". Below this is a table with columns "Average" and "StdDev".

	Average	StdDev
North:	4281316.800m	0.0037m
East:	259539.883m	0.0048m
Elev:	98.000m	0.0063m
Min		Max

Clicking on the Green check will allow the user to continue storing more points.

Clicking on the Red 'X' will cancel the GPS reading.

When the storing points operation is complete, the user may exit to the main menu.

However, the logging function is still active. Closing the logging file is shown at the end of this section.



## GPS Raw Only – Fully Kinematic Logging

Fully Kinematic Logging is considered a standalone operation. Thus, Fully Kinematic Logging can only be initiated by the GPS Raw Only command. Click on Equip – GPS Raw Only to begin.

This will take the user to the GPS Raw Only screen, select the Settings tab.

Current	Receiver	Settings
Mode:		Fully Kinematic
Readings Per Point:		10
Log Interval:		1.00 seconds
<input type="checkbox"/> Include diagnostic data		

Select the Fully Kinematic option from the Mode dropdown along with a Log Interval. The red 'X' will exit the logging initialization. The Green check will continue to the Log Raw Data File screen.

Log Raw Data File	
Free Memory: 884.94Mbytes	
<input checked="" type="checkbox"/> New File:	Newer_File
<input type="checkbox"/> Existing:	New_File.log
Antenna Height:	2 m
Observer ID:	Peter

In the Start New File screen the user may start a new log file or append an existing log file.

*Note: Options available on the Start New File screen will be receiver – specific.*

The Antenna Height and Observer ID may be set from this screen as well. The Start New File screen allows for the initial parameters of the log file to be activated. Clicking on the Back arrow will go back one screen. Clicking on the Red 'X' will exit out of the logging routine.



Clicking on the Green check will continue to the Monitor/Skyplot screen.

Monitor/Skyplot			
Quality	Position	SATView	SATInfo
Status:	FIXED	Satellites:	16/17
Latency:	N/A	Local Elev:	98.0066m
Local Northing:	4281320.6569m		05/10/2018
Local Easting:	259539.9935m		11:08:30.2
HDOP:	1.10	VDOP:	2.10
TDOP:	2.00	PDOP:	2.37
GDOP:	3.10		
HRMS:	0.017m		
VRMS:	0.033m		

The user may view any of the tabs within the Monitor Skyplot screen during the logging session. Since the mode is Fully Kinematic, the software assumes the user would only like to log data continuously and the logging function will remain active.



## GPS Raw Only - Closing the Logging File

The logging file can be closed in any of three ways:

- Start a new file
- Close File button / Close a Site Tag
- Equip – GPS Utilities – GPS Raw Utilities – Close File
- Exit the software

Starting a new file follows the same procedure as outlined in this section. Exiting the software via File – Exit will prompt the user to close the current log file. Selecting Equip – GPS Utilities – GPS Raw Utilities will offer receiver specific options, including the Close File option.

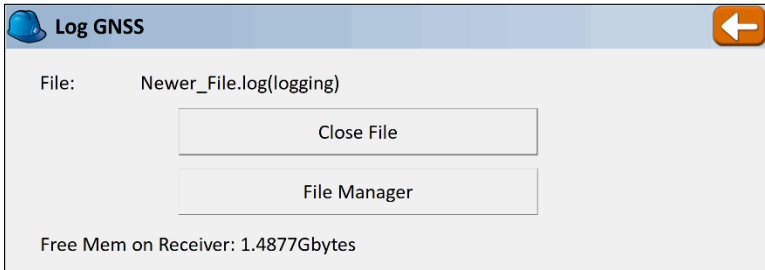

Selecting Close file will close the current logging file.

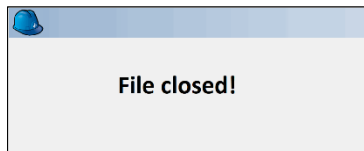



## 5.7 Configure (General)



This tab allows you to select settings and preferences that apply to observations taken in the field. These options remain set from job to job. If an option is not applicable, it is grayed out. Configure is accessible from within any routine where the C or Configure Icon is present. These options can also be accessed by pressing ALT-C on the keyboard.

**Configure** [Green Checkmark] [Red X]

**General** | View

- Store Fixed Only (GPS)
- Prompt for Total Station Setup
- Prompt for Height & Description
- Prompt for Point Notes
- Prompt if Duplicate of Backsight or Last Reading (TS)
- 3D Mode
- Use Virtual Keyboard

No. of Readings to Avg -      TS: 1      GPS: 1

Enter/Store Icon - TS:      Read & Store

Enter/Store Icon - RTS/GPS:      Read & Store

---

Configure / General Tab / Options

<input checked="" type="checkbox"/> Store Fixed Only (GPS)	<input type="checkbox"/> Always Display Average Statistics
<input type="checkbox"/> Prompt for Total Station Setup	<input type="checkbox"/> Show Slope Info in STK Points
<input checked="" type="checkbox"/> Prompt for Point Notes	<input type="checkbox"/> Visual Alert in STK for GPS not Fixed
<input type="checkbox"/> Prompt if duplicate of Backsight or Last Reading (TS)	<input type="checkbox"/> Use Groups of Codes/Desc
<input type="checkbox"/> 3D Mode	<input type="checkbox"/> Show Codes/Desc as Buttons
<input type="checkbox"/> Use Virtual Keyboard	
<input type="checkbox"/> Use Virtual Joystick	
<input type="checkbox"/> Use Graphic Icons in Survey	
<input type="checkbox"/> Use Audible Alerts	
<input type="checkbox"/> New Job Use Alphanumeric Format	
<input type="checkbox"/> Use Point Symbols	
<input type="checkbox"/> Use Line Details	
<input type="checkbox"/> Use Layerized Points by Feature Code	
<input type="checkbox"/> Use Ctrl Pts for Map Selection	
<input type="checkbox"/> Use Unique IDs for Linework	
<input type="checkbox"/> Show Advanced Backsight	

- **Store Fixed Only (GPS):** When enabled, only data gathered in the fixed (locked) status will be stored to the point file. If you attempt to store data when the receiver is not fixed, a message will appear stating, "Position is not fixed! Continue storing?" The program will prompt to store the point anyway. This allows for overwriting the Store Fixed Only option without having to go back to the Configure menu.





- **Prompt for Total Station Setup:** This option determines whether or not the software will display the current setup and orientation values each time the user enters a survey routine.
- **Prompt for Height and Description:** When this option is enabled, you will be prompted after each shot to enter the target height, description, and the option to attach photographs to points/lines. Though this adds an extra prompt screen to each shot, it can reduce errors, as you no longer have to anticipate the shot and get the correct information entered ahead of time. This prompt screen is shown in the figure below. Two additional icons, for tangent curves ("AFIT") and elevation only ("ZO") appear on a third screen. The elevation only option will allow use of a line code such as "EP" for elevation only but will not draw linework through that point. The triple dot icon in the lower right cycles through the icon options, all of which can be entered by hand. When this screen appears, you will have the option to enter a point description and change the point number and the target height. Note that all the field codes identified in the Feature Code List under File are available for touch or arrow key selection, provided this option is activated in Job Settings (Use Code Table for Descriptions). Also, if you enter the first character of a code (for example, "I" for IP), the first field code starting with that character will be highlighted, allowing you to arrow key to the one you want, or accept the highlighted option. This entry is not case-sensitive. Disable the Prompt For Height and Description option to save time while storing points, or if you are certain that your height and description will not change from shot to shot. If the option is disabled, you must be sure that the correct target height and description have already been entered.

The screenshot shows a software window titled "STORE PTS" with a blue header bar. In the top right corner of the header, there are three icons: a black square, a white square with a pencil and the text "EP", and a red square with a white "X".

The main content area is titled "FIXED(SIM)" and contains the following data:

- Pt: 67 (with a blue and red icon to its right) 0 ft
- SATS:14
- N:418326.4990ft
- HRMS:0.046ft
- E:1779746.3125ft
- VRMS:0.089ft
- Z:397.2935ft
- PDOP:3.200

Below the data is a "Desc:" label followed by a text input field and a camera icon on the right.

At the bottom, there are four buttons: "MON/SKY", "CONFIG", "OFFSET", and "STORE".

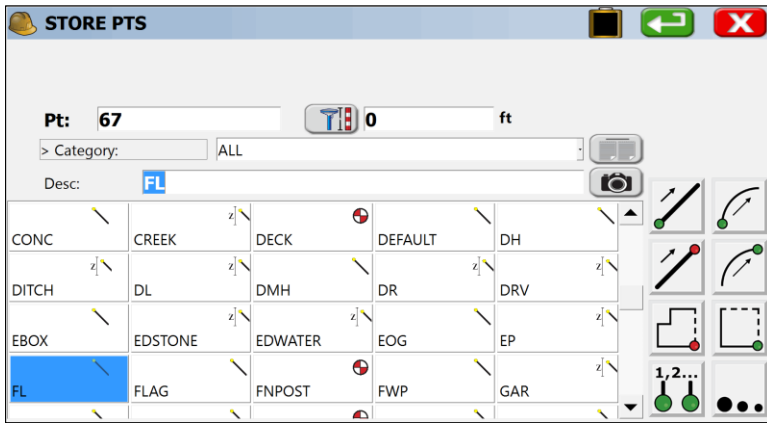

Regarding heights, the  icon will toggle between the current height of measurement (e.g. prism height, antenna height) and a list of previously stored heights. It is useful when switching between commonly used heights such as full pole extension and normal setting.

*Note: In the Height/Description Prompt screen, you will see pre-defined Feature Code points indicated with a large dot. 2D polylines will show as a simple line, 3D polylines will show as a line with a "Z" indicator, and descriptions entered that are not found in the feature code list will appear with the "field book" symbol above.*

- **Prompt for Point Notes:** Point Notes are additional descriptions that can be stored with a point. A regular point consists of a point ID (number or alphanumeric), northing, easting, elevation, and description (up to 256 characters). Point Notes are a way to add an unlimited number of lines of text to a point. With this toggle enabled, you will be prompted for notes after collecting a point. The notes are stored in a file with the same name as the coordinate file, but with a .NOT extension. For example, a job called TOPO.CRD would have a note file called TOPO.NOT.
- **Prompt If Duplicate of Backsight or Last Reading (TS):** This option allows for the user to be alerted if a Backsight or Last reading is duplicated.
- **3D Mode:** This option allows you to toggle between 2D or 3D data. In 2D mode, all elevations will be stored as 0.0 and there are fewer prompts on many screens such as the backsight screen (no instrument height and target heights).
- **Use Virtual Keyboard:** This option provides a software keyboard for PCs without keyboards. SurvPC offers a soft-button version of the arrow keys when the virtual keyboard is selected in the robotics screen. This allows some tablets and PCs without arrows to use the total station joystick feature.



- **Use Virtual Joystick:** This option provides a software Joystick for PCs without joysticks.
- **Use Graphic Icons in Survey:** This option toggles between the traditional letter icons (in versions prior to SurvPC 2.0) and the graphic icons for options like Store Points and Offset. Specifically, for Portrait View, it also organizes the main 5-tab menu items into icons so there is no scrolling of the main menu (see contrasting views below). Although the Store Points screen icons appear immediately when this option is on, the main menu icons in portrait view appear only after re-starting the program.
- **Use Audible Alerts:** Turn on or off PC sound alarms.
- **New Job Use Alphanumeric Format:** When this option is enabled, SurvPC will allow alphanumeric point numbers such as 2A or T1105. When this option is disabled, SurvPC will only allow numeric point number entry. Note: this setting only affects new jobs, not existing ones. Using purely numeric files can increase operation speed in very large files, however, this option limits points to just over 32,000. An alphanumeric format will be necessary for files larger than 32,000 points. A comment will be added in the Rw5 file “—CRD: Alphanumeric” or “—CRD:Numeric”, based on the format used.
- **Use Point Symbols:** When turned on, point symbols established for point-based codes in the Feature Code List command will draw on the screen. The value of this option is to distinguish features visually while working in the field, and the symbols stay in the dxf file and can be exported to a .dwg file. Shown below is a tree symbol defined by the code "dt" for "deciduous tree". Point do not have to have defined symbols in the Feature Code List, so even when clicked on, points can still plot without symbols.

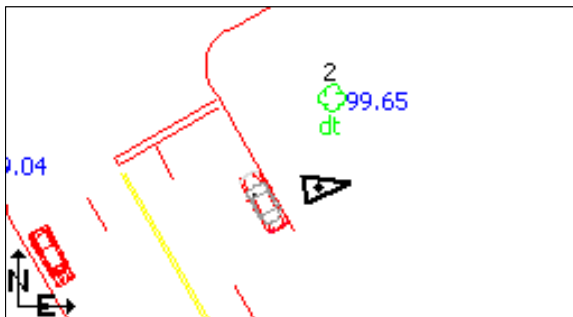



- **Use Line Details:** This option has 2 effects. First, when clicked on, linework will "auto-draw" any time a feature code is changed or new points with codes are added to an existing point list. Secondly, the option enables selecting of lines (by clicking on them), leading to options to edit the line, extend the line, or create new lines emanating from the vertices' near the clicked point.

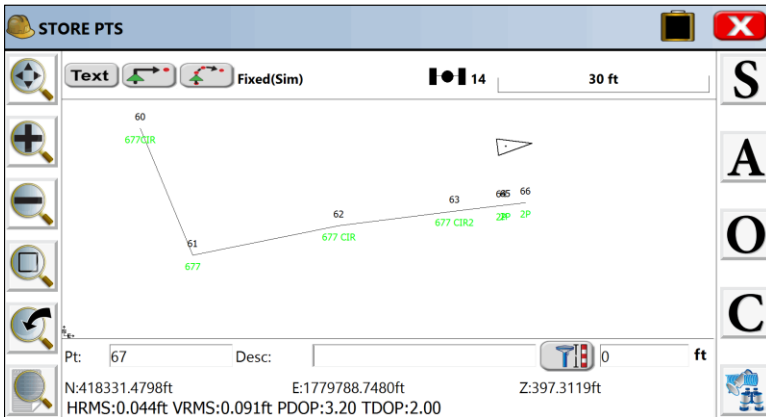
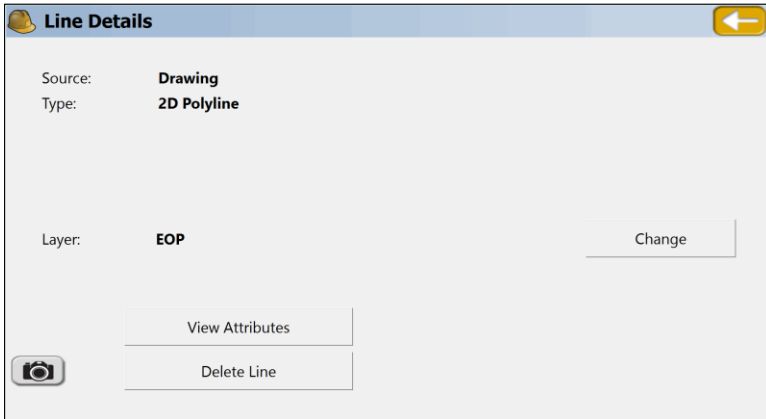

This line can be clicked within the map screen without issuing any command, and the Line Details screen will appear at left. If you tap too close to a point ID, then Point Details will appear. But you can also click lines within the command Store Points. This provides additional options to Extend the Line and draw a New Line from the nearest vertice to the picked point. These options are discussed in detail in the section on Feature Code List found in the File menu.

- **Use Layerized Points by Feature Code:** This feature allows the user to use point layers.



- **Use Ctrl Pts for Map Selection:** This allows users to use Control Points for Map Selection.
- **Use Unique IDs for Linework:** This will impact the meaning of the "Start Line" special code, which is also appended using the green circle icon shown here:  
When clicked on, then start line will not only append the start line code (such as "ST") to the feature code, but will increment the code number by 1, as in EP2 ST. If the last line was EP2, then using the start line icon on another EP would create a code EP3 ST. In this way, there is no need for an end line code, since each distinct EP has its own numeric identifier (as in EP1, EP2, EP3).
- **Attach Photographs to Points/Lines:** This feature appears when the program detects a PC operating system capable of using an external camera or built-in camera. In Portrait mode, the option appears as shown below. Also turn on Height/Description Prompt in Configuration to use the Camera feature. Then when field measurements are taken by GNSS, total station or other means, you can tap the camera icon within the Height/Description prompt screen (middle below). Then you can select an image that is stored anywhere on the field data collector, or you can click "Capture" and take a photo. The images are associated with the point or line, and more than one image can be attached. Each individual image can be given a description. If multiple photographs are associated, you can tap the right arrow to move through the gallery of photos and their associated descriptions. You can Remove any if desired. Any single Photo can be Changed to better match the description (or removed and added again).

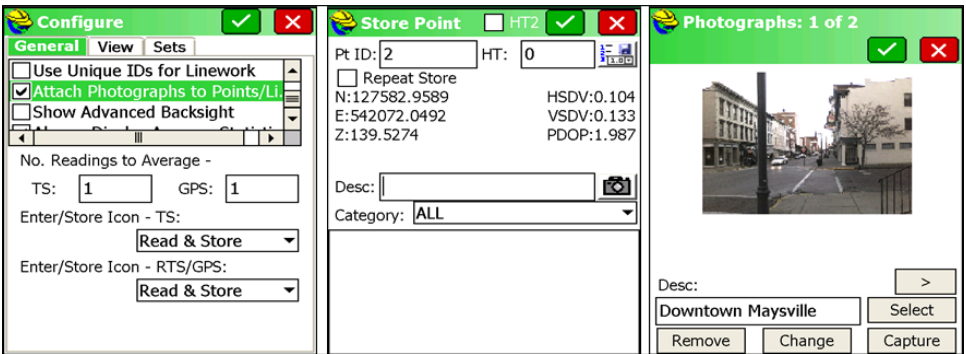

When adding photos by "Select" or by "Capture", the Next and Prev buttons will appear in Landscape mode when more than 1 picture is attached.

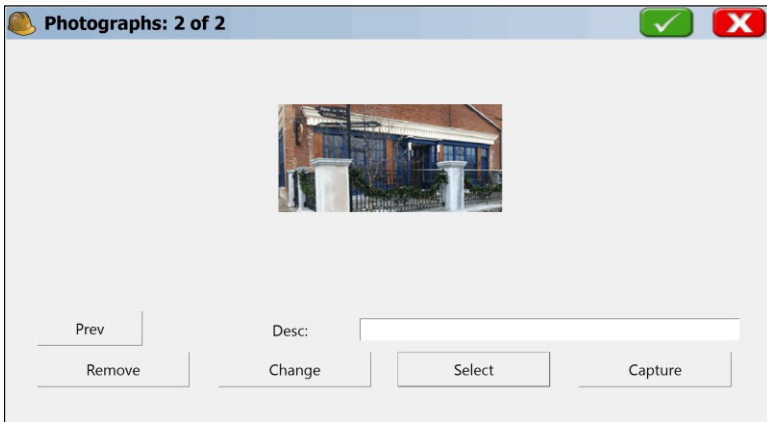
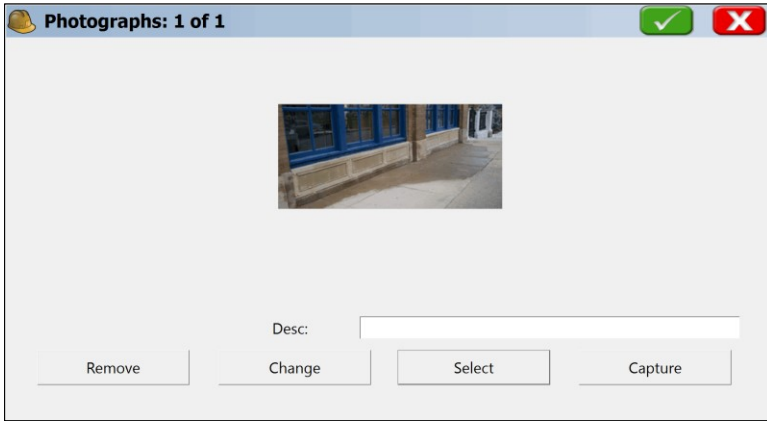

The Camera feature, when activated here, also appears both in Line Details (when clicking a Line) and within Input-Edit GIS Data in Map, Tools menu.

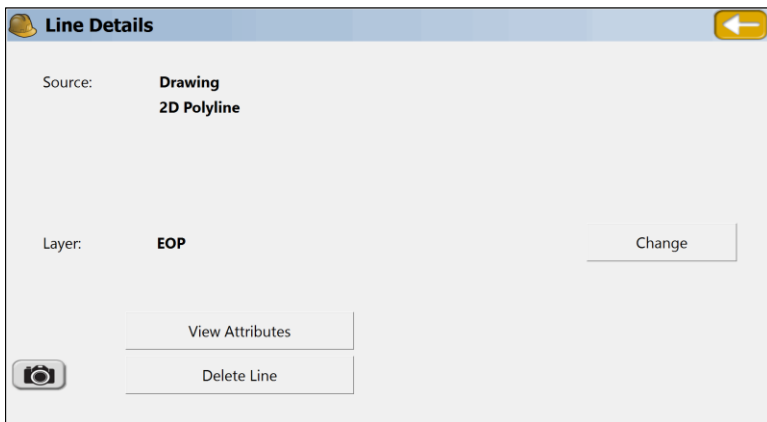
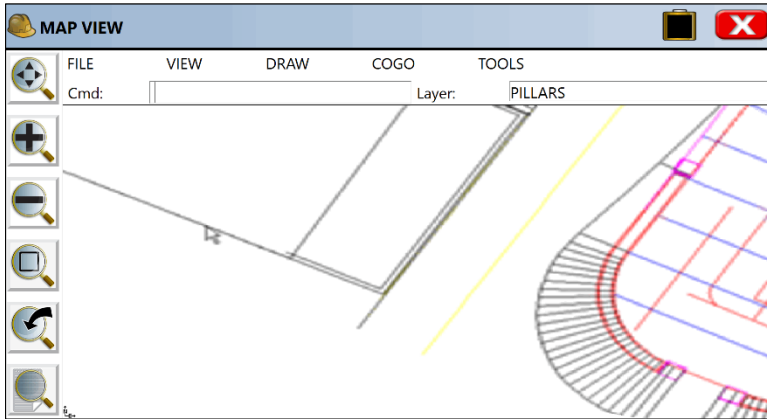

In these commands, you can review photos and continue to Capture, Select, Change or Remove photos associated with the selected entities.

- **Show Advanced Backsight:** This option applies to total station work and allows for multiple reference backsight points, each one of which can be sighted and measured multiple times. Then, based on least squares analysis, the program will compute a "best fit" backsight for purposes of zeroing the total station. The command can be likened to a special Resection for purposes of zeroing the instrument (or setting it to a backsight azimuth). This is a more commonly used in Europe. You can still obtain very accurate backsights to a single backsight point using direct and reverse methods, so most surveyors do not turn on this feature. The feature has some built-in error checking to prevent improper calculation if the coordinates for the backsight reference points are not correct or in proper relation to each other.



- **Always Display Average Statistics:** This option defaults on the "Always Display Average Statistics" option within Store Points, A for Average. An example of this average statistics display for a sample of 10 GPS readings appears here:

Valid Readings:	10/10	
Fixed:	10/10	
	Average	StdDev
North:	418351.992ft	0.0357ft
East:	1779729.081ft	0.0257ft
Elev:	397.285ft	0.0011ft
	Min	Max

- **Show STK Directions from Last Stored Point:** Directions to the new point to stake will be in reference to the last stored point using the Point List option.
- **Show Slope Info in Stake Points:** This option will display slope information from your current reading to the target point to stake.
- **Visual Alert in STK for GPS not Fixed:** This will alert the user when in a Stakeout routine the current position mode is not Fixed.
- **Use Groups of Codes / Descriptions:** This will allow the user to use Groups of Codes and Descriptions for Stored Points.





- **Show Codes / Descriptions as Buttons:** This will allow the user to show the Codes and Descriptions as Buttons.

With both ‘Use Groups of Codes / Descriptions’ and ‘Show Codes / Descriptions as Buttons’ enabled, the user can quickly set the code and descriptions of stored points.

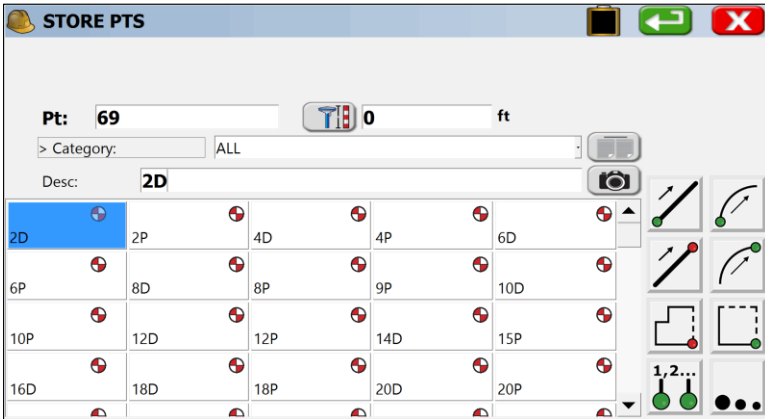
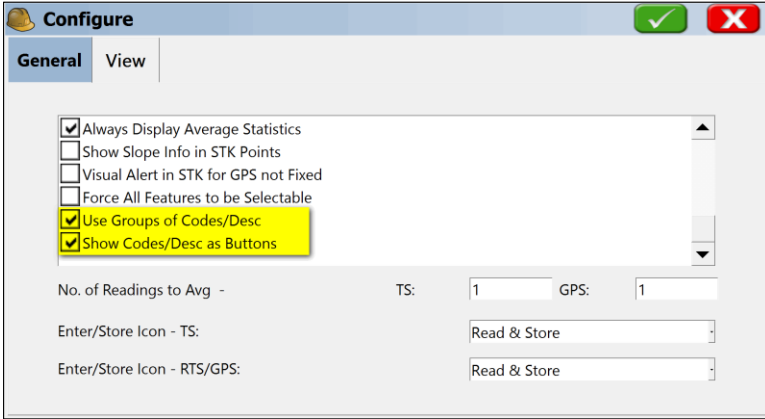



**No. of Readings to Avg (TS & GPS):** Specifies the number of readings that will be taken and averaged on each observation. Values between 1 and 9 are accepted for Total Stations and 1-999 for GPS. If the tolerance is exceeded between readings, a warning screen will appear.

*Note: The Num Dist Readings setting does not apply to Manual Total Station mode. In this mode, you can use the Calculator to average distances. When prompted for Slope Distance, enter “?” to bring up the calculator. Choose the Scientific Tab. Follow the tutorial below to average three values:*

*141.213 Enter*

*141.211 Enter*

*141.220 Enter*

*Now press + on the keyboard twice and with the first +, 141.220 is added to 141.211 to get 282.431, then with the second + you get 423.6440.*

*Then enter 3 and type “/”(backslash) for divide. This gives the result: 141.2147.*

*Choose the Copy button at the bottom of the screen, then Paste at the top.*

**Enter/Store Icon (TS & RTS/GPS):** Since the Enter key is a convenient and popular way to take shots in the Store Points command, SurvPC allows you to specify the effects of this key. These different functions of the Enter key apply not only to Store Points but also to Elevation Difference. The function of the Enter key is set separately for Total Stations and GPS. The different options are described below. Note: Most users choose Read then Store.

- **Store Then Read:** This option similar to the effects of the Read key. After a backsight, the first time Enter is used, it will take the shot and display the results. Then when you foresight the next point, Enter will “Store Last, Read Next”. This procedure is best used with the above Hgt/Desc Prompt on Save disabled. If that option is on, then when you turn to the new shot and press Enter, the new shot doesn’t take right away, but instead, you are prompted for the target height and description of the previous shot. That could cause some confusion. But with Hgt/Desc Prompt turned off, this method can be very efficient. You press Enter and take your first shot. You see the results displayed and can alter descriptions or target heights or point numbers for that shot. You sight your next foresight, and press Enter and the previous shot is correctly stored and the next is taken. The information is displayed. You can review and alter it. You sight your next foresight, press Enter and store the last shot and shoot the next, etc.
- **Read then Store:** With this option, the Enter key takes the shot and stores the point. This option works very well with the Hgt/Desc Prompt on Save turned on, in which case Enter key takes the shot, then displays the results and provides an opportunity for editing as in the Store Point dialog shown above.
- **Read or Store:** The first Enter key takes the reading and the second Enter key stores the reading.



## 5.8 Configure (View)



These settings control the reporting appearance of the stakeout navigation information. The **Method** setting allows you to choose the stakeout information that is most appropriate for your situation and personal preference. The options for Method are described in detail below.

**Configure Stakeout Info** [✓] [✗]

General **View**

Method: In-Out & Left-Right to Ref Collapsed Report: Navigate Data

Ref. Object: Point Point ID: 7 [☰] [📍]

Move Relative To: Ref. Object

Use CL for Ref. Object (when applicable)  Proximity STK(Pts)

---

**Configure Stakeout Info** [✓] [✗]

General **View**

Method: Deflection L/R & Distance Collapsed Report: Navigate Data

In-Out & Left-Right to Ref  
North-South & East-West  
Azimuth & Distance  
Bearing & Distance  
Direction L/R & Distance  
Deflection L/R & Distance

Position  
Navigate Data  
None

Use CL for Ref. Object (when applicable)  Proximity STK(Pts)

### Method Options:

- **In-Out, Left-Right:** Nearly all surveyors choose this method with total stations, with instrument as reference object. Set to Reference Object as Instrument, if you are staking a point located 100 meters from the instrument, and take a measurement at 97 meters, the program will respond, "Out 3". If the **In-Out, Left-Right** method is selected, then the **Ref. Object** and **Move Relative to:** options become available to further define left-right. Although "Instrument" is the normal reference with a total station, the Ref. Object box allows you to choose a stationary



point by which the directions will be referenced. This point can be either the instrument or a known point. If Ref. Object is set as instrument, then left is defined as left of the line between the instrument and the rod. Likewise, if Ref. Object is point then left is defined as left of the line between the point and the rod. The second option, **Move Relative to**, allows you to decide whether the directions are relative to the stationary point selected in **Ref. Object** or to the moving Rod.

- **North-South, East-West:** When total stations are used, the direction to go in stakeout can be North-South, East-West. For instance, the program might advise, "North 3.582, East 1.917." This method is better suited to GPS work and is subject to having a sense, in the field, of the north direction.
- **Direction to Point—Azimuth, Distance:** This directs you to the point for stakeout by the total distance and the azimuth, in either the 360-degree circle or a 400 degree circle if configured to grads.
- **Direction to Point—Bearing & Distance:** Similar to Azimuth and Distance except bearings referenced from North and South are used for the direction.
- **Direction L/R & Distance:** Available only in GPS mode, you are advised "Right", "Left" or "On-Line" as you move to the target point, along with a distance update.
- **Deflection L/R & Distance:** Available only in GPS mode, you are given precise advice in terms of the deflection angle left or right to turn, as you are walking, to move to the target point. Both Direction L/R and Deflection L/R (shown below) use the recent vector of your movement to determine the correction L/R instruction. Navigate mode in Store Points (an option made available in Job Settings) defaults to Deflection L/R & Distance.



The image displays two screenshots of a surveying software interface, likely for a total station or similar instrument. Both screenshots show a graphical view of a station layout and associated data.

**Top Screenshot:**

- View:** Fixed(Sim)
- Scale:** 80 ft
- Station Data:**
  - Pt: 69 Desc: STK62 677 CIR FILL 0.019ft
  - N:418308.0713ft E:1779701.3102ft Z:397.2886ft
  - HRMS:0.049ft VRMS:0.093ft PDOP:3.20 TDOP:2.00
  - P:62 Z:397.308ft 677 CIR**
  - Fill 0.019ft**
  - D-O:3°41'29" Dist:58.303ft**

**Bottom Screenshot:**

- View:** Fixed(Sim)
- Scale:** 20 ft
- Station Data:**
  - Pt: 69 Desc: STK62 677 CIR CUT 0.004ft
  - N:418323.9909ft E:1779722.4427ft Z:397.3112ft
  - HRMS:0.040ft VRMS:0.074ft PDOP:3.20 TDOP:2.00
  - P:62 Z:397.308ft 677 CIR**
  - Cut 0.004ft**
  - Out 33.961ft Right 14.874ft**

- **CL In-Out, Forward-Back if Alignment available:** This option overrides the settings above, and if the stakeout involves a centerline, the program will direct the user by distance in to or out from the centerline and forward or back along the centerline. Note in the graphic below that the Method is set to North-South & East-West, but the actual report is "Out" and "Forward" because "Use CL for Ref. Object" is clicked on.
- The **Use Horizontal Clock system** option converts the 360 (or 400) circle into a 12-hour circle with 60 minutes per hour and is used in certain military applications. North is 12 o'clock.

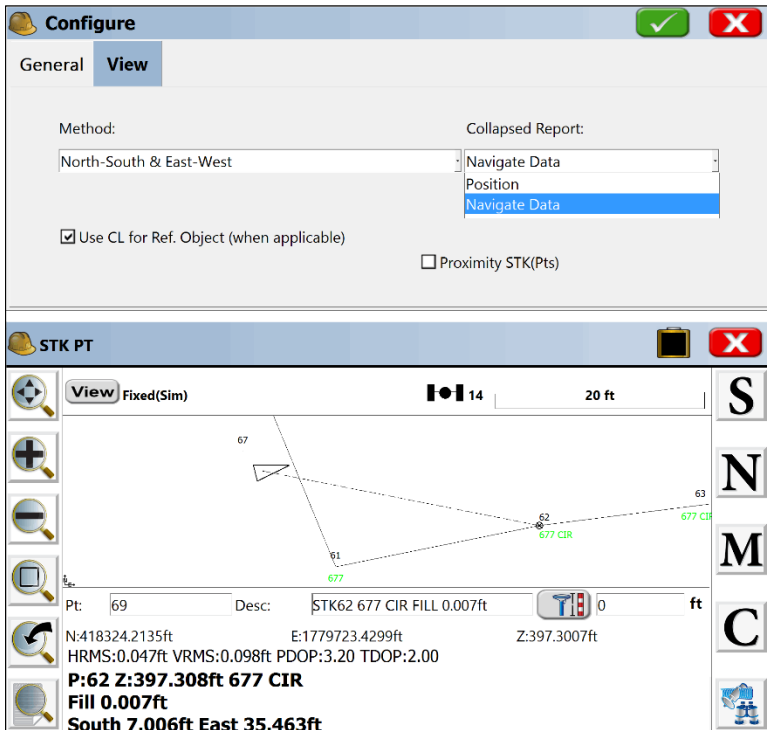

- **Collapsed Report** in the upper right of the View Tab of Configure applies to the various Stakeout commands and has 3 options: Position, Navigate Data and None. This option allows for more screen space in stakeout. Shown above is the most popular setting, Navigate Data. When the down - arrow is tapped in the field, the multiple lines of stakeout data (up to 6 as shown above) will collapse down to 1 or 2 lines. The "None" setting shows only one line, the next Point line with Description and Height. The "Navigate Data" setting also shows the stakeout instruction (above right). The Position option shows the x,y,z position of the target point and also the next Point line. Pressing the up - arrow restores the larger screen. Using a PCDemo version of the software, F2 collapses the screen and F3 expands the screen. With a PC or field PC, it is also possible to tap and hold the lower graphic horizontal line and drag down to collapse the text and enlarge the graphics, but since tap and hold also pans the screen, the sensitivity of this procedure makes it hard to use--you must tap and drag down just a few pixels of lower graphic window, precisely. It is easier to use the up and down - arrow keys, which are more convenient.



## 5.9 Configure (Sets)



This tab allows the user to define how the software will handle angle sets, reciprocals, and direct and reverse.

The image displays two screenshots of the 'Configure' dialog box, specifically the 'Sets' tab. Both screenshots show a list of surveying routines with checkboxes and 'Set Collection Routine Options'.

**Top Screenshot:**

- Backsight (Read D&R)
- Traverse (Read D&R)
- Resection (Read D&R)
- Topography (Read D&R)
- Stakeout (Read D&R)
- Reverse Face - Angles Only

Set Collection Routine Options

- Review Readings
- Review Sets
- Store Raw Data for Duplicate Points

Set Order: Robotic Set No. of Sets: 1

**Bottom Screenshot:**

- Stakeout (Read D&R)
- Reverse Face - Angles Only
- Auto Turn
- Auto Read
- Calculate Reciprocals

Set Collection Routine Options

- Review Readings
- Review Sets
- Store Raw Data for Duplicate Points

Set Order: Robotic Set No. of Sets: 1

- **D&R:** The user can choose to measure direct and reverse readings for backsight, traverse, resection, topography, or stakeout routines. If the user measures direct and reverse for the backsight readings, all foresight readings that also are recorded direct and reverse will be recorded and computed as angle sets. If the backsight reading is only measured direct, then foresight points that are measured direct and reverse are then combined to produce an average observation record for the vertical circle, which is stored in the .rw5 file as a sideshot (SS) record. For calculation purposes, the routine only averages the distances using both vertical circle readings and uses the direct horizontal reading for the direction. Both the direct and reverse readings are stored in the .rw5 file as a note record. When



disabled, (default setting) only the direct foresight shot will be taken. This option improves accuracy on elevation measurements. The Resection D&R will also apply to Remote Benchmark.

- **Reciprocal Calc:** The Reciprocal Calculation option has three settings: No, Prompted, and Always. It governs the calculation of the elevation of foresight points taken with a total station, where a backsight measurement is also taken. When set to Always, the program will calculate the distance to the foresight point and delta elevation by combining the foresight and backsight measurements. When set to Prompted, the program will detect the backsight measurement and ask the user if the occupied point should be calculated using both previous foresight and current backsight. If set to No, the program calculates foresight points based only on the foresight measurement. If, for example, you had a vertical difference of +1.2 going up to the foresight, and then when you backsighted the difference was -1.0, the program would calculate the average difference (1.1) and would lower your occupied point by 0.1 “on-the-fly”, prior to conducting foresights. This is useful for multi-setup topo work, in particular, where no further adjustment is anticipated. For closed traverse or high-precision work, it is recommended that you run with Reciprocals off and use the adjustment options found in your office software or within Cogo, Process Raw File, in SurvPC. Reciprocals, because they re-calculate your occupied point by combining the backsight with the prior foresight information, should be used with care, because they will degrade the precision of the work if backsights are not precisely measured, with correct target heights.
- **Reverse Face Angles Only:** When taking Face 1 and Face 2 foresights, or when doing Set Collection, the program will use the distance from the direct reading only but will use the horizontal and vertical angles from both the direct and reverse face readings. This setting is repeated and displayed within Configure in Set Collection. Any change in either location controls the setting. (Note that in Manual Total Station, you will be prompted for reverse face distance, but the entry will not be used.) When using robotic total stations, which do not take distance measurements in reverse face, setting Reverse Face Angles Only is necessary to use motorized direct and reverse readings.
- **Auto Turn:** This option is for motorized instruments only and when enabled (by default) will automatically turn the instrument to the reverse face.
- **Auto Read:** This option will immediately take a reading after the instrument has turned to the reverse face. You must make sure that the auto targeting option is on. This is enabled by default.





## 5.10 Configure (IMU)

To use any IMU feature in SurvPC, it is first necessary to activate the sensors in the receiver. This is located in Equip – GPS Rover, and checking the box ‘Use IMU’ on the Receiver tab. Note that the position rate of 5Hz is required to use IMU features.

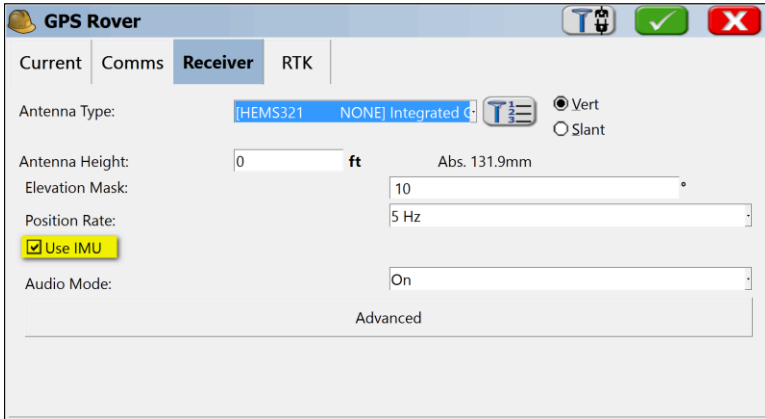

Individual IMU features of SurvPC are controlled in Equip – Configure, on the IMU tab:

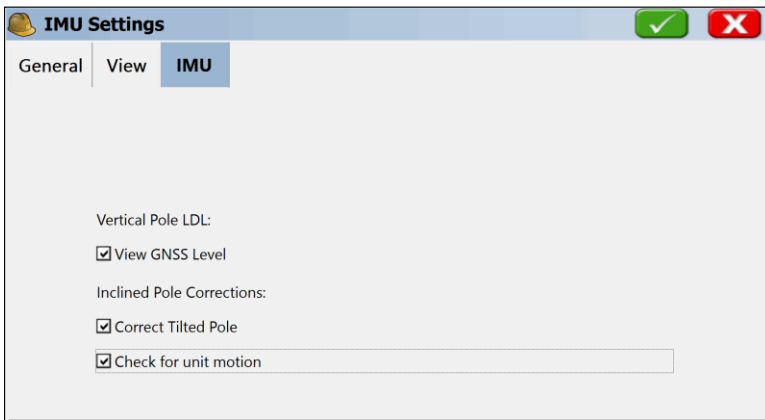

The internal PC compass may be used for declination. This option will show if the PC has a recognizable compass.

SurvPC allows the option to view the GNSS level on the live survey screen.



Check the box for View GNSS Level to view the GNSS level on the live survey screen. The digital level will let the user know visibly whether the receiver is level enough to store a reading. A green circle indicates a reading can be stored, and red indicates that the incline of the pole exceeds the user configured tolerances, blocking the reading. The digital level is aligned on the X/Y axis of the receiver. *The face of the receiver should be facing towards the operator for intuitive display.*

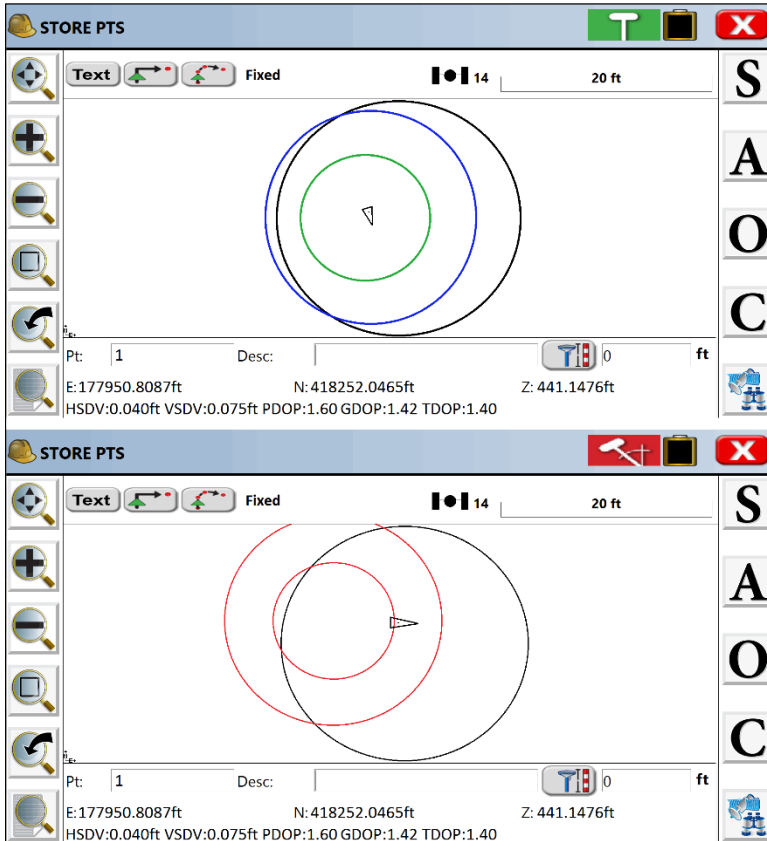

Users who wish to stay within level tolerance but do not like the appearance of the digital level can simply turn off View GNSS Level in the configure screen. As long as the IMU is enabled in the receiver configuration, SurvPC will still block reading which exceed the level tolerances. The Green or Red 'GPS Pole ICON', located in the top-right of the Screen, serves as an indicator of whether a reading can be stored.



Tolerances are configured from the main menu under Equip – Tolerances:

Label	Value	Unit
HRMS Tolerance:	0.098	ft
VRMS Tolerance:	0.197	ft
PDOP Tolerance:	3.500	
Stakeout Tolerance:	0.328	ft
"Navigate To" Tolerance:	0.049	ft

The Level Tolerance defines the amount of error that will be accepted when storing points. The tolerance is defined as the amount of distance error allowable on the ground and thus is a function of both the incline of the pole and the rod height.

### Storing Measurements at an incline

Some receivers also include a compass, and by combining the heading of the instrument with the incline, the software can adjust for positional error due to the incline of the pole. To use this feature, go to Equip – Configure and check the box for ‘Correct Tilted Pole’.

Vertical Pole LDL:

View GNSS Level

Inclined Pole Corrections:

Correct Tilted Pole

The Incline Tolerance in the tolerances menu defines the maximum amount of tilt allowable. Most receivers begin to lose accuracy when tilted more than 20 degrees.

In the Store Points screen, the ICON in the top bar and the appearance of the digital level provide information to the user about whether a point can be stored.

Please see the following examples:



**Example 1:** The red circle indicates the receiver is not within level tolerances, but the green icon in the top-right indicates that a reading can be stored, and the software will account for the incline of the receiver.

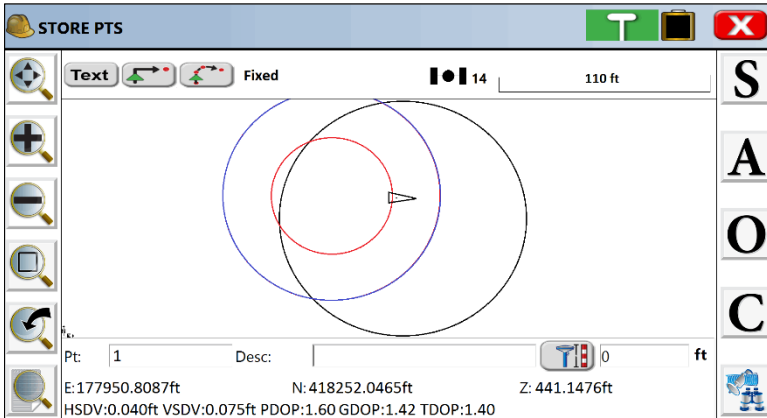

**Example 2:** The red icon in the top bar indicates that the receiver is tilted too far to correct for tilt, as configured in the tolerances dialog by the Incline Tolerance (for example, more than 20 degrees). The bubble level also shows that the receiver is very unlevel. No point can be stored.

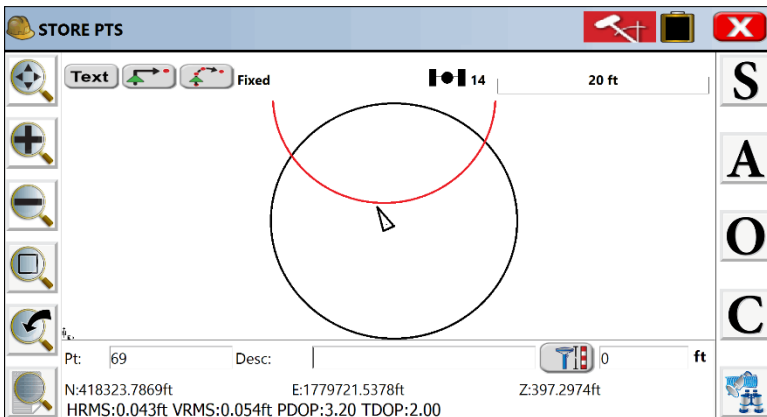



**Example 3:** Correcting for incline measurement can be unreliable in areas of magnetic noise. SurvPC will indicate this situation using a magnet symbol in the top bar. If magnetic noise is detected, SurvPC will block any reading outside of the level tolerance. No point can be stored in this state.

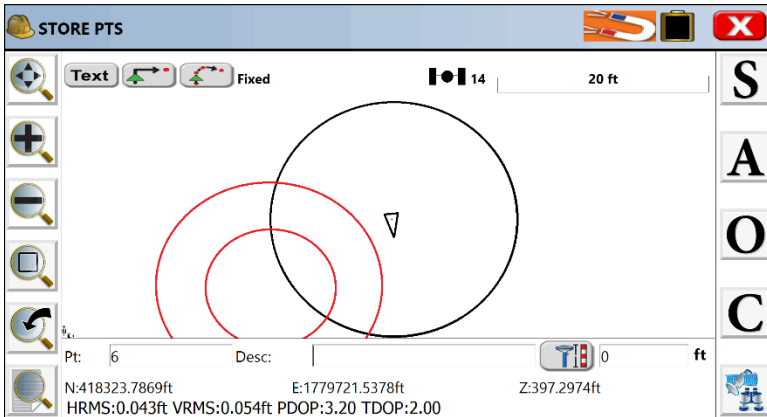

**Example 4:** To store a reading in areas of magnetic noise, simply level up the pole to within level tolerance. The icon now indicates that there is magnetic noise, but the receiver is level enough to store. Note that in this state, due to the magnetic noise, no adjustment will be made for incline.

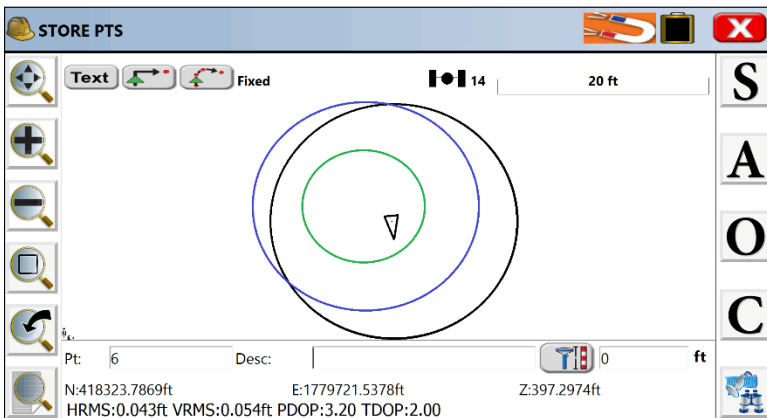



**Example 5:** The digital level is green, indicating that the receiver is within level tolerance, and the icon is green, indicating that a point can be stored. When Correct For Tilt is enabled in this situation, corrections will still be applied for the small tilt of the pole.

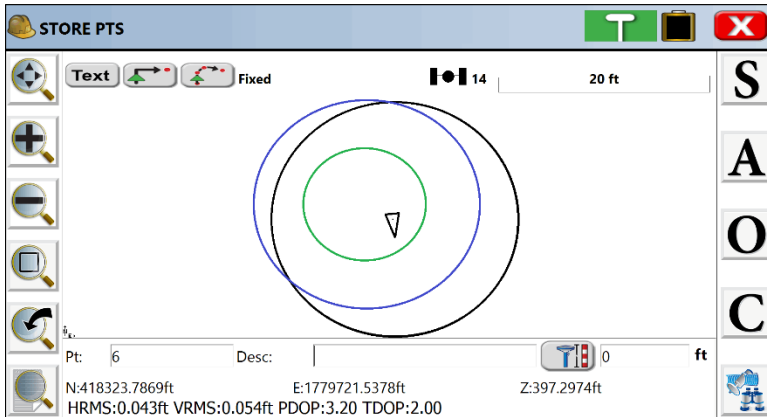

ICON	Description
	OK to store. Either within level tolerance, or if incline adjustment is being used, within incline tolerance.
	Magnetic interference detected, unsafe to store. Must level the receiver to within level tolerances to store.
	Unit motion detected, possibly unsafe to store. If you press store in this state, SurvPC will wait up to 1 second for the compass to stabilize before storing the point.
	Magnetic interference detected, but unit is within level tolerance, so it is OK to store. Tilt adjustments will not be made.
	Out of tolerance. Either outside of level tolerance specifications, or outside of incline tolerance specification (if tilted pole is being utilized).
	Error State. This indicates that there is a delay between the sensor messages and the positions. Unsafe to store the point.



## 5.11 Hybrid+



Hybrid+ allows the use of a robotic total station and GPS receiver simultaneously to increase survey reliability and efficiency. The new Hybrid+ module is a paid addition to SurvCE/SurvPC which allows full simultaneous integration of total stations, GNSS, and all available sensors for the most flexible and efficient survey experience on the market. Users can mix and match any GNSS and RTS from the Carlson driver library for a custom setup.

The Hybrid+ setup wizard is designed to step you through configuration of Hybrid+, allowing multiple setup options based on user preference. We will walk through two methods of setup and explain the basics of Hybrid+.

### Instrument Status Icon:

New instrument status icons are now available in most screens. The icon is a single panel for single instrument use, or a double panel when Hybrid+ is active.



■ Red: The instrument is not connected.

■ Yellow: The instrument is connected but an accurate position is unavailable.

- Yellow for GPS: Receiver mode is not Fixed RTK. (Receiver mode is Autonomous, DGPS, RTK Float, etc..).
- Yellow for Robotic Total Station: Standby or lost prism.

■ Green: The instrument is connected and an accurate position is available.

- Green for GPS: Receiver mode is Fixed RTK.
- Green for Robotic Total Station: Locked / Tracking.

### Flexible Search Options for Total Station:

The search icon allows for instance access to all available search methods.



Press the right side of the icon (the down arrow) to see a list of available search types: General Search, Search Left, Search Right, GPS Search, RC Search, etc. The chosen search will begin when the selection is made. Press the left side of the icon to repeat the last user selected search. A STOP ALL option is also available in the drop-down list.



## Laser Pointer Icon for TS:

Enable and disable the laser pointer from any live survey screen.

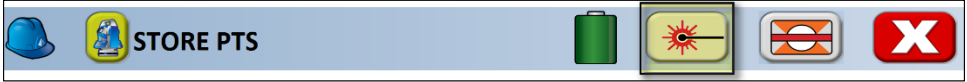

## Setup Method 1: Hybrid+ Setup Using Grid Coordinates

Use this setup method if you run a GPS receiver on grid coordinates and would like to configure your robotic total station to run on grid coordinates.

Begin by configuring a GPS Receiver as you normally would, setting up RTK corrections and achieving a fixed position using either a radio or network connection.

Monitor/Skyplot				
Quality	Position	SATView	SATInfo	Ref
Status:	FIXED		Satellites:	14/18
Latency:	1.0s		Local Elev:	97.2956ft
Base Selection:		VRS_RTCM3		
Local Northing:		5003.2547ft		10/25/2017
Local Easting:		4936.3075ft		08:53:15.0
HDOP:	1.30		VDOP:	1.82
TDOP:	1.26		PDOP:	2.24
GDOP:	2.57			Reset RTK
HRMS:	0.041ft		Disconnect	Connect
VRMS:	0.063ft		Connected	

To enter Hybrid+ mode, tap the instrument selector in the top bar of the menu. Select Hybrid +. Click yes when prompted “Switch to Hybrid Survey Mode?” If you have not registered the Hybrid+ module, you will be prompted to temporarily enter demo mode to try Hybrid+. You can revert to your full registered copy at any time by exiting and reentering the software.

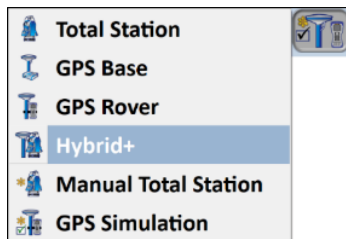





If you have not purchased the Hybrid+ module, you will be prompted to temporarily enter demo mode with the Hybrid+ module to try. Demo Mode will only allow a maximum of 15 points. You can revert to your full registered copy of the software by exiting and relaunching the software.

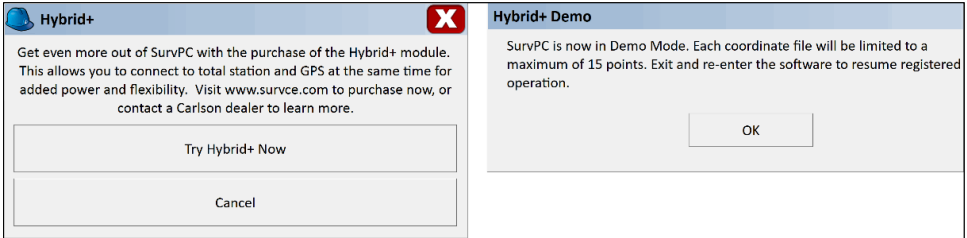

If this is the first time you have used Hybrid+, you will be prompted to use the wizard for configuration. Click on 'Yes' to continue.

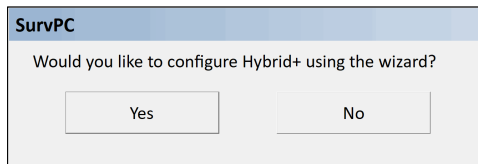

The first step of setup is to configure the Robotic Total Station (RTS) and GPS receiver. For this example, we have already configured the GPS (note the green check icon). Press 'Configure TS' to begin the configuration of the robotic total station.

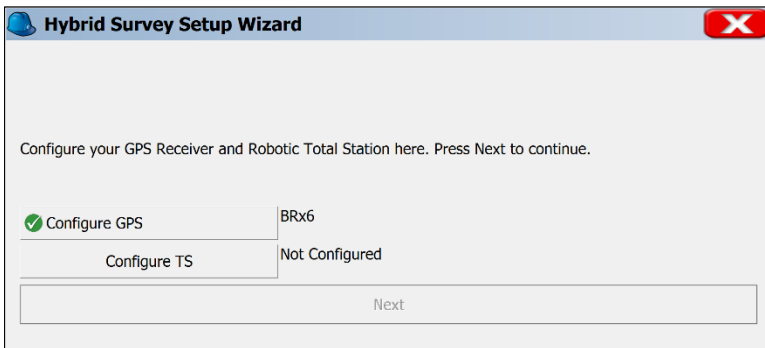

Configure the robotic total station as you normally would.

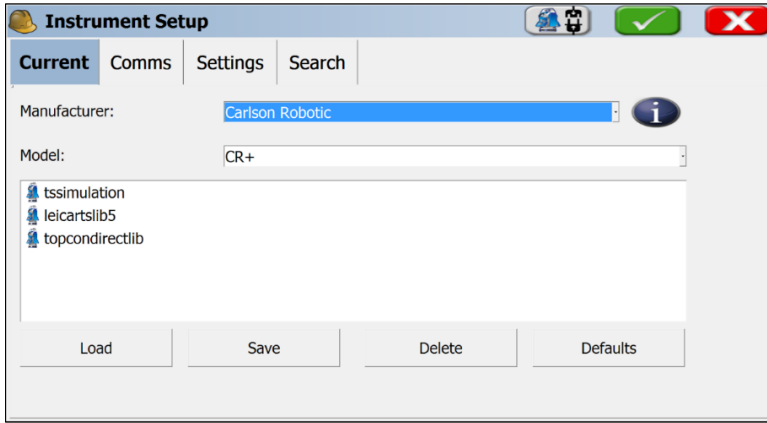

Press the green check to connect and return to the wizard. Both buttons should now have a green check to indicate the instruments are configured. Press 'Next' to continue.

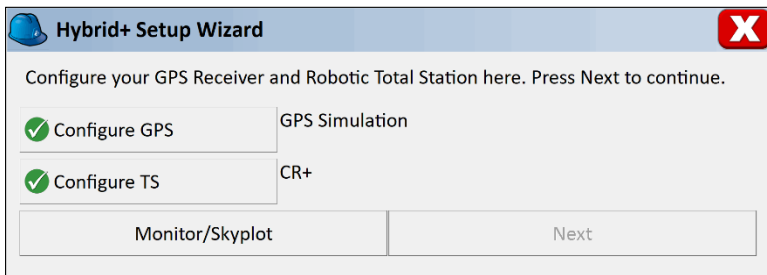

Next, the wizard will guide you through setting your GPS and RTS heights. Measure the height of the prism (from the tip of the pole to the center of the prism) and measure the height of the GPS receiver (from the found to the reference mark on the antenna, slant or vertical). Enter in these values in the screen.



**Hybrid+ Setup Wizard** X

Measure prism height and gps rod height. When you are satisfied with the heights, press Next. From this point forward, changing either height in the software will automatically adjust the other.

TS Prism Height:  ft

GPS Antenna Height:  ft

GPS ARP:  Slant  Vertical

Hybrid Offset:  ft

The software will now calculate the fixed offset between the center of the prism and the GPS receiver. From this point forward, changing either height (GPS or RTS) will automatically adjust the other using this fixed offset value. Press 'Next' to continue.

To survey in Hybrid+ mode, it is necessary to ensure the robotic total station and GPS are measuring points on the same coordinate system. The next step in the wizard will address this. In this example, we will configure the robotic total station to use state plane grid coordinates using the Hybrid Resection procedure.

**Hybrid Survey Setup Wizard** X

The next step is to ensure that your Total Station and GPS Receiver coordinate systems are synchronized. To establish grid coordinates for your job, choose Use Hybrid Resection. If you have existing control in your job, choose Use Localization.

Use Hybrid Resection

Use Localization

In order for coordinates to match over long distances, it is necessary to scale either the robotic total station or GPS measurements, Select your scaling method. In this example, we are using 'Scale TS (Ground to Grid)'. Click 'Next' to continue.



The screenshot shows a dialog box titled "Hybrid+ Setup Wizard" with a close button (X) in the top right corner. The main text reads "Select Scaling Method". Below this, there are three radio button options: "Scale GPS (Grid to Ground)", "Scale TS (Ground to Grid)", and "No Scaling". The "Scale TS (Ground to Grid)" option is selected. At the bottom, there are two buttons: "Back" and "Next".

The next screen will allow the Hybrid Resection procedure to begin. When ready, click on 'Perform Hybrid Resection' to continue.

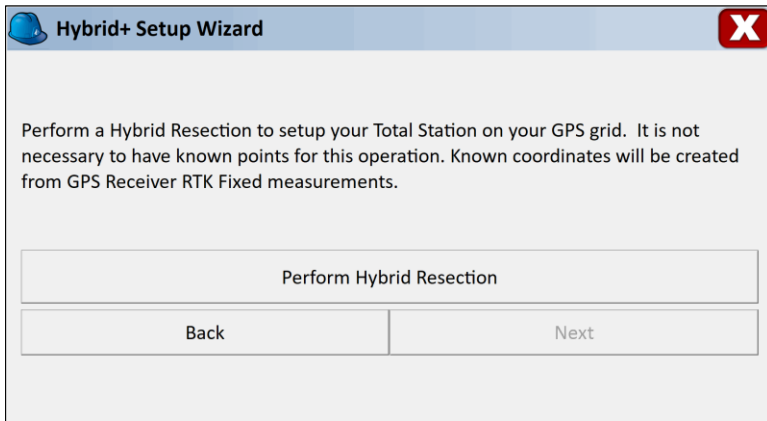

The screenshot shows a dialog box titled "Hybrid+ Setup Wizard" with a close button (X) in the top right corner. The main text reads "Perform a Hybrid Resection to setup your Total Station on your GPS grid. It is not necessary to have known points for this operation. Known coordinates will be created from GPS Receiver RTK Fixed measurements." Below this text is a large button labeled "Perform Hybrid Resection". At the bottom, there are two buttons: "Back" and "Next".

It is not necessary to have any known coordinates to perform a hybrid resection. The known points will be measured from the GPS receiver. Simply aim the total station to the prism and press 'Read Hybrid Position' to measure a resection point. The software will measure the total station position and the GPS position at the same time, synchronizing the readings automatically by time. You will be prompted to store the resection point if you desire. Move to a new location and repeat.



Point ID:  Read Hybrid Position

Desc:  Calculate

N:   Ignore Elev

E:   Use GPS

Z:  Robotics (Alt+J)

Status: Standby  
Horizontal: 4°59'10"  
Zenith: 93°37'40"

Inst Hgt:  0 m  2 m

When you are satisfied with your resection, press ‘Calculate’ to view your results and store the calculated position of the robotic total station. The software will then set the orientation angle on the robotic total station and return to the wizard. The next step is to ‘Perform a Cross-Check’. Cross-check will measure a position simultaneously using the robotic total station and GPS receiver. It will then compare the coordinates match based on the displayed tolerances.

Coordinate systems are now synchronized. You can perform a Cross-Check to confirm that your GPS Receiver and Total Station coordinates match.

Hybrid Pos. Tol.(SDist):  0.131 ft

Hybrid Pos. Tol.(Elev):  0.246 ft

Cross-check tolerances can be augmented within this screen. Perform a Cross-check by pressing ‘Perform Cross-Check’. Once setup is complete, the software will use these tolerances to detect any unacceptable deviations between the RTS and GPS positions. If an unacceptable deviation is present, a warning screen will pop-up to warn the field engineer.

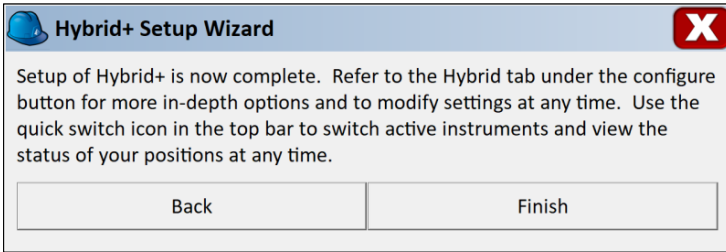

Setup is now complete. Press 'Finish' to exit the wizard and begin using Hybrid+.

### Setup Method 2: Hybrid+ Setup Using Known Local Coordinates

Use this method if you typically run a robotic total station on ground coordinates and want to localize the GPS receiver to ground coordinates.

Begin by configuring a robotic total station (RTS) normally, configuring the instrument and setting your backsight and orientation.

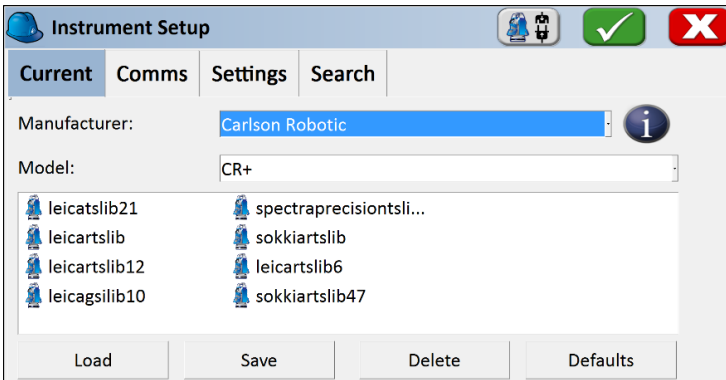

To enter Hybrid+ mode, tap the instrument selector in the top bar of the main menu. Select Hybrid+.

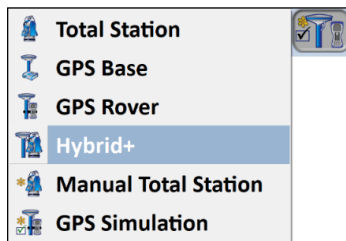



If you have not purchased the Hybrid+ module, you will be prompted to temporarily enter demo mode with the Hybrid+ module to try. Demo Mode will only allow a maximum of 15 points. You can revert to your full registered copy of the software by exiting and relaunching the software.

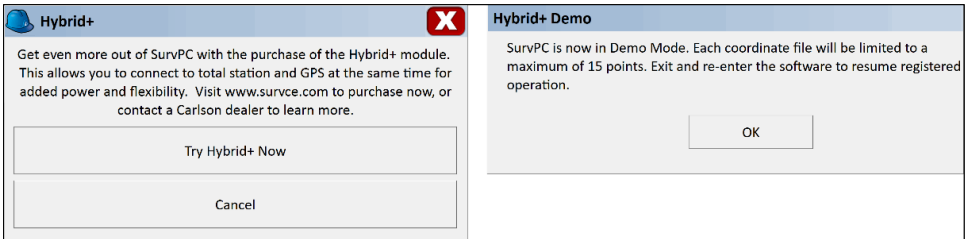

If this is the first time you have used Hybrid+, you will be prompted to use the wizard for configuration. Click on 'Yes' to continue.

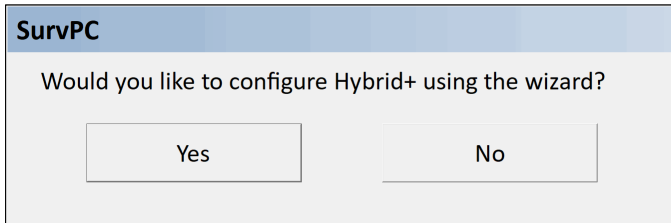

The first step of setup is to configure the Robotic Total Station (RTS) and GPS receiver. For this example, we have already configured the robotic total station (note the green check icon). Press 'Configure GPS' to begin the configuration of the GPS receiver.

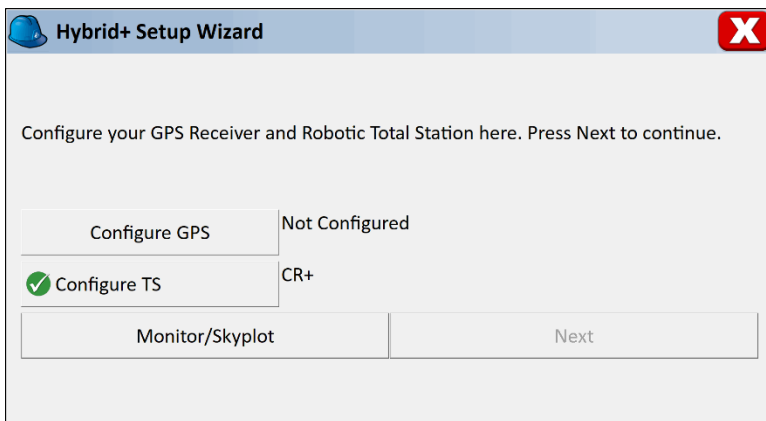



Configure the GPS as you normally would, ensuring a valid RTK correction link. Once the GPS receiver is configured, both buttons will show green check icons. Press 'Next' to continue.

**Hybrid+ Setup Wizard**

Configure your GPS Receiver and Robotic Total Station here. Press Next to continue.

Configure GPS      GPS Simulation

Configure TS      CR+

Monitor/Skyplot      Next

Next, the wizard will guide you through setting your GPS and RTS heights. Measure the height of the prism (from the tip of the pole to the center of the prism) and measure the height of the GPS receiver (from the ground to the reference mark on the antenna, slant or vertical). Enter in these values in the screen.

**Hybrid+ Setup Wizard**

Measure prism height and gps rod height. When you are satisfied with the heights, press Next. From this point forward, changing either height in the software will automatically adjust the other.

TS Prism Height:      2.2000      ft

GPS Antenna Height:      2.3000      ft

GPS ARP:       Slant       Vertical

Hybrid Offset:      0.1000 ft

Back      Next

The software will now calculate the fixed offset between the center of the prism and the GPS receiver. From this point forward, changing either height (GPS or RTS) will automatically adjust the other using this fixed offset value. Press 'Next' to continue.





To survey in Hybrid+ mode, it is necessary to ensure the robotic total station and GPS are measuring points on the same coordinate system. The next step in the wizard will address this. In this example, we will configure the GPS receiver to existing ground coordinates using the 'Use Localization' procedure. Select 'Use Localization' and click 'Next' to continue.

**Hybrid+ Setup Wizard**

The next step is to ensure that your Total Station and GPS Receiver coordinate systems are synchronized. If you want to setup your Total Station using points read from your GPS, choose Use Hybrid Resection. If you want setup GPS using points read from your Total Station choose Use Localization.

Use Hybrid Resection

Use Localization

Back Next

There are two methods of performing the localization for Hybrid+, localize manually and auto-localize. Localize Manually will proceed to the SurvCE localization screen where a localization may be created by measuring individual points and adding them to the localization. Auto-Localize will proceed to the Store Points screen and switch the active instrument to the robotic total station. The auto-localization will complete once enough points are measured.

We will run an example of the Auto-Localization method below. Select 'Auto Localize' and click 'Next' to continue.

**Hybrid+ Setup Wizard**

Select Localization Method:

Continue setup without localizing. The GPS Receiver will automatically localize to your ground coordinates as you survey with your Total Station. It will not be possible to switch to GPS mode until the localization is complete.

Localize Manually

Auto Localize

Back Next



The setup wizard will now complete. However, no points have been measured and a Cross-check has not been performed, so Hybrid+ is not yet fully active.

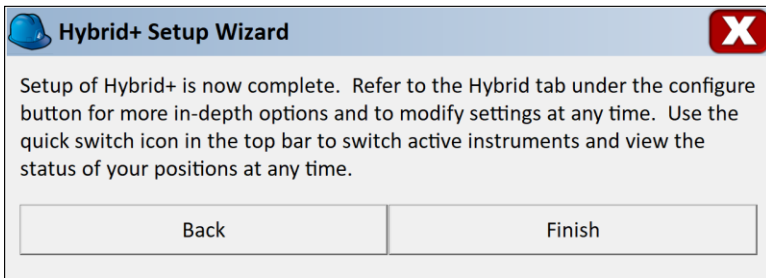

Click on 'Finish' to exit the Hybrid+ Setup Wizard. SurvCE will now automatically set the active instrument to the robotic total station. It will not be possible to switch to GPS mode until enough points are measured with the robotic total station to form a good auto localization. From the main menu, select Survey – Store Points. The Store points routine will be used to form an auto-localization.

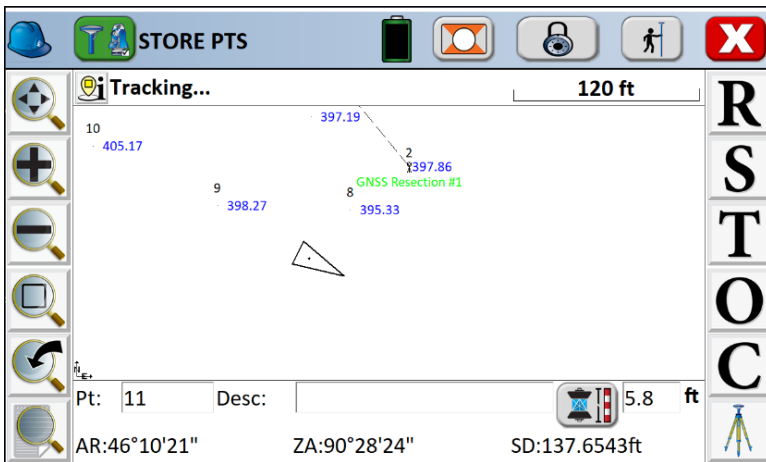

Within the Store Points screen, each time a point is stored with the robotic total station, the GPS measurement is collected at the same time. A localization will be formed in the background by analyzing all measurements pairs and selecting the best quality measurements.

The status of the auto localization can be viewed at any time by selecting Equip – Configure – Hybrid tab.



The screen shot above reflects the status of an Auto Localization routine before any points are stored. When enough points are stored the Auto Localization status will switch from ‘Insufficient Points [0]’.

Before the Auto Localization is complete, an attempted switch to GPS mode will be blocked by the software with a warning message.

Use the robotic total station to store several points. An ideal localization will form a triangle around the robotic total station, but it is not necessary to intentionally form a localization. The software will calculate the best localization continuously. When an auto localization is calculated, features like Smart Lock, Follow Me, and GPS Search will be enabled, based on user settings. Once the auto localization is complete, a switch to GPS mode using the instrument status icon can be made. At that time, the auto localization will be finalized and no further localization points will be collected. Press the quick switch icon to switch to GPS Mode.

Press ‘Yes’ to finalize. SurvCE will proceed to the Localization screen.

From this screen, you can review your localization points and quality as you would a manual localization.



**Localization**

System | TS | GPS | **Points** | By Helmert

Pt ID	Northing(ft)	Easting(ft)	Elevation(ft)	H Res(f)
Auto-Localization Pt 5	418179.2762	1779575.0007	403.6775	0.029
Auto-Localization Pt 6	418203.9331	1779648.9891	403.6939	0.037
Auto-Localization Pt 8	418124.3060	1779598.0156	401.8089	0.024

Scale:1.000064  2pt Rotate Only  
Avg HRes:0.0340 Avg VRes:0.0035

Add Delete Edit On/Off  
Load View Monitor Save

Press the green check to finalize the auto localization routine. With the localization complete, the next step is to perform a Cross-Check. The software will direct the user to the cross-check procedure automatically.

**STORE PTS**

Tracking... 120 ft

SurvPC

Confirm Hybrid Setup by performing a Cross-Check?

Yes No

Pt: 11 Desc: 5.8 ft

AR:46°09'26" ZA:90°28'27" SD:137.5361ft

Click 'Yes' to perform a cross check. The Cross-check procedure will measure a position simultaneously using the robotic total station and GPS receiver and verify that the coordinates match. If the coordinates match within tolerances, the localization is good and the robotic total station and GPS receiver are on a matching coordinate system. Hybrid+ setup is complete.



Tolerances can be adjusted in the Hybrid tab of Equip – Configure. Once setup is complete, SurvCE will use these tolerances to detect unacceptable deviations between the robotic total station and GPS positions. Unacceptable deviations will be shown as a warning to the user throughout the survey session.

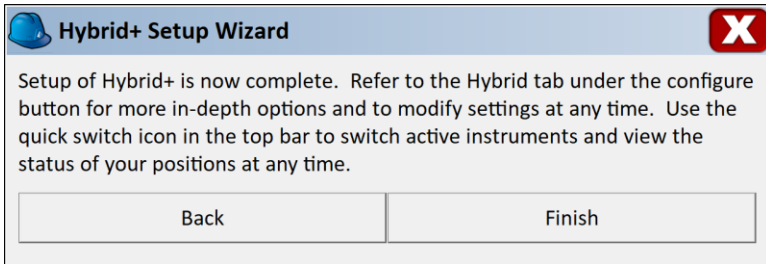

Setup is now complete. Press ‘Finish’ to exit the wizard and begin using Hybrid+.



## Using Hybrid+

Once Hybrid+ is active, SurvCE can be used normally. The new Instrument Status icon, shown on the upper-left of the screen, will indicate the status of the configured instruments at all times. The checkmark (shown below the instrument icon) will indicate the active instrument. While both the robotic total station and GPS receiver are connected and may be measuring at any time, the *active* instrument will control the options available in the main menu along with the display in active survey screens. The color on each side of the Instrument Status icon indicates the status of position quality.

- Red: The instrument is not connected.
- Yellow: The instrument is connected but an accurate position is unavailable.
  - Yellow for GPS: Receiver mode is not Fixed RTK. (Receiver mode is Autonomous, DGPS, RTK Float, etc..).
  - Yellow for Robotic Total Station: Standby or lost prism.
- Green: The instrument is connected and an accurate position is available.
  - Green for GPS: Receiver mode is Fixed RTK.
  - Green for Robotic Total Station: Locked / Tracking.













*Note: The Instrument Status icon shown above is displaying the robotic total station as active. The yellow color indicates it is not currently tracking a prism. The GPS icon is green, indicating the current Fixed RTK status.*

The instrument status icon can be selected from any screen to quickly switch active survey modes. When the GPS instrument is active, the menus and display of SurvCE will be in GPS mode. When the robotic total station instrument is active, the menus and display of SurvCE will be in total station mode.

JOB:				
File	Equip	Survey	COGO	Road
1 Total Station		6 Localization		
2 GPS Base		7 Monitor/Skyplot		
3 GPS Rover		8 Tolerances		
4 GPS Raw Only		9 Peripherals		
5 Configure		0 GPS Utilities		

*Note: Menus shown in GPS mode.*



JOB:					
File	Equip	Survey	COGO	Road	
1 Total Station		6 Localization			
2 GPS Base		7 Check Level			
3 GPS Rover		8 Tolerances			
4 GPS Raw Only		9 Peripherals			
5 Configure		0 TS Utilities			

*Note: Menus shown in Total Station mode. Check Level and TS Utilities are shown in the main menu.*



## Hybrid+ Features and Settings

Hybrid+ settings can be accessed from the main menu by selecting Equip – Configure and navigating to the Hybrid tab.

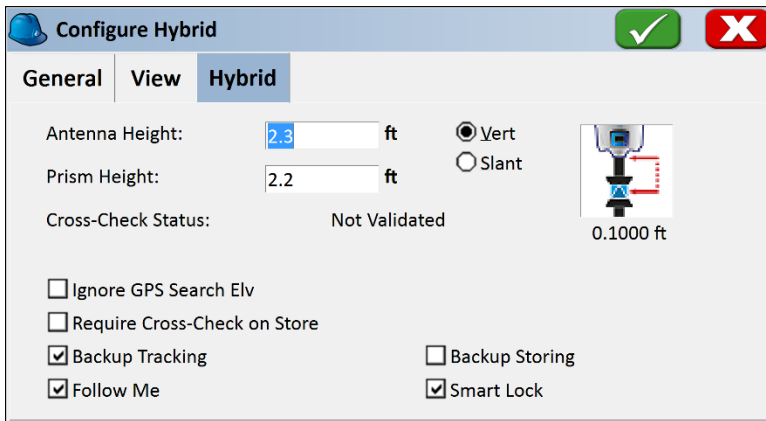

The Hybrid tab allows editing / viewing several settings.

- **Antenna / Prism Height:** The Antenna and Prism Heights can be viewed and/or edited. Updating either height elsewhere in the software will automatically adjust the other.
- **Cross-Check Status:** The Cross-Check Status is shown – this will inform if any recently compared GPS and robotic total station points have been compared successfully. The screen shot above indicates Cross-Check has not yet completed. If localization has been used, the auto localization status and/or other localization information will be visible under the Cross-Check Status.
- **Ignore GPS Search Elv:** GPS Search is always available when Hybrid+ is active. To use it, select the down - arrow to the right of the search icon from any active screen, and select 'GPS Search'.



In locations where the GPS cannot get a quality position and elevations are relatively flat, it may be useful to ignore the less accurate elevation measurement of the GPS receiver and still perform GPS searches using only the horizontal position to locate the prism. Enable 'Ignore GPS Search Elv' to do this.





- **Require Cross-Check on Store:** Enable this option to force the software to calculate a cross-check on every stored point. When enabled, this option will affect workflow based on mode.
  - **In GPS Mode:** If the robotic total station is not locked on the prism, a search will be performed.
  - **In Robotic Total Station Mode:** If the GPS is not Fixed RTK, the user will be warned.

*Note: Only the active instrument's measurements will be stored in the RW5 file.*

This option forces the software to check both instrument positions for each stored point, allowing the user to see a warning if either instrument's position is sub-optimal.

- **Backup Tracking:** When Backup Tracking is enabled, SurvCE will automatically display the backup (and inactive) instrument position on the screen when the primary (and active) instrument's position is unavailable. The backup instrument position will be displayed in red. This means if the robotic total station is active, and the E.D.M. is obstructed, the software will display the GPS position in the bottom bar as well as the GPS location triangle until the robotic total station position is restored.

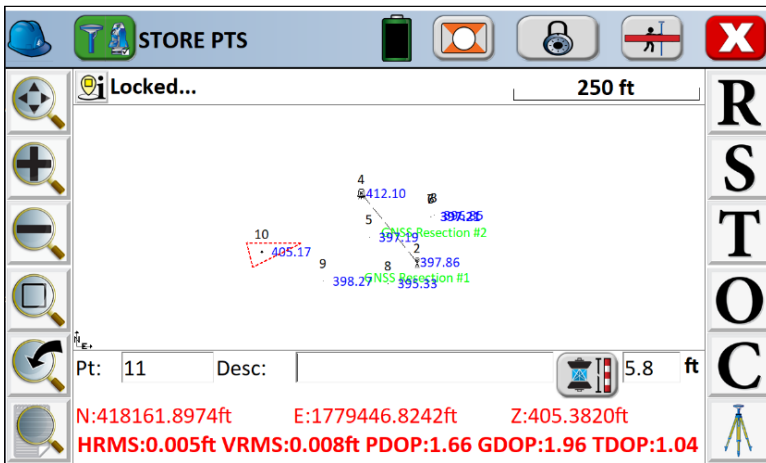

*Shown in the image above, the robotic total station is the active instrument, but is in a locked state (the E.D.M. is not firing). Since no position is available from the active instrument, and backup tracking is enabled, SurvCE is displaying the backup position of the GPS in red.*

In the Stake Points screen, the stakeout directions will continue to be issued using the backup position if the active position is lost. If the 'Follow Me' option is enabled, the robotic total station will continue to follow the prism as it moves toward the field point. If the 'Smart Lock' option is enabled, the software will detect when the prism is within close proximity to the target point and automatically lock. This ensures final directions to the point are from the active



instruments (in most cases where precise stakeout is needed, this will be the robotic total station).

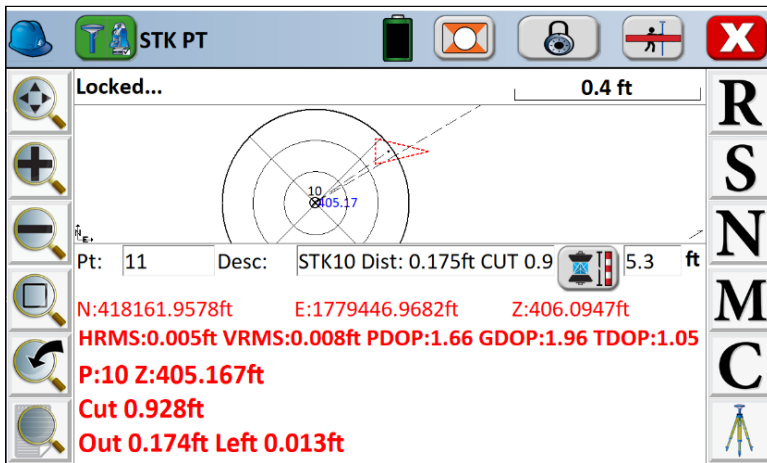

*Shown in the image above, the robotic total station is the active instrument, but it is in a locked state (the E.D.M. is not firing). Since no position is available from the active instrument, and backup tracking is enabled, SurvCE is displaying the backup stakeout directions from the GPS position in red.*

- **Follow Me:** When the 'Follow Me' option is enabled, the robotic total station will automatically 'follow' the GPS receiver as it moves, turning every few seconds to the location of the GPS so that it is always ready to take a measurement at any time. The 'Follow Me' option causes a turn to the prism, but not a lock. This is sometimes called 'GPS Tracking', as the robotic total station is following the prism not by optical tracking, but by using the location of the GPS. Pressing the standby button in the top bar will put the instrument in manual standby mode and temporarily disable the 'Follow Me' option. 'Follow Me' will resume when a position is stored or lock is reacquired.
- **Backup Storing:** When the 'Backup Storing' option is enabled, the backup position will be stored when the primary (and active) instrument's position is unavailable. For more manual control, leave this option disabled, and simply tap the quick-switch icon in the top bar to switch to the active instrument and store the position.
- **Smart Lock:** When the 'Smart Lock' option is enabled, the software will monitor the motion of the GPS. When the movement of the GPS slows (i.e. the surveyor is slowing to take a measurement), the robotic total station will rotate to the prism and optically lock on to the prism. 'Smart Lock' can operate by itself, or in conjunction with 'Follow Me'. If the software detects further movements of the GPS while attempting to lock, the Smart Lock routine will cancel automatically in the background. Pressing the standby button in the top bar will put the instrument in



manual standby mode and temporarily disable Smart Lock. Smart Lock will resume when a position is stored or lock is reacquired.

- **IMU:** Hybrid+ can take full advantage of tilt sensors on the GPS receiver by applying them to both the robotic total station and the GPS.

When IMU is enabled during Hybrid+:

- The tilt sensors of the GPS receiver can be used to adjust the measurements of the robotic total station prism. This is true even when the GPS receiver is *not* Fixed RTK.
- The digital level bubble can display in active survey screens even when the robotic total station is the active instrument.
- SurvCE can warn the user when the robotic total station measurements are outside of level tolerance.

### **Exiting Hybrid+**

Hybrid+ mode will end automatically when SurvCE is exited, or a new job is started. Alternatively, a return to normal survey mode can be made by selecting any other survey mode using the quick switch icon in the main menu.



## 5.12 Localization

This command allows you to define the project coordinate system, geoid usage, and scale factors, as well as align on a local coordinate system for GPS. Further discussions on localization are found in Tutorial 2 near the end of the manual.

### System Tab

Click **Edit Projection List** to add to the list and to create user-defined projections. The user may select a predefined or create a user-defined coordinate projection system

**Localization** [Green Checkmark] [Red X]

System | TS | GPS | Points | By Helmert

Projection: [Edit Projection List]

USA/NAD83/KY North

Projection: Lambert\_Conformal\_Conic\_2SP

Datum: NAD83

Ellipsoid: GRS 1980

Convert WGS84 to NAD83

---

**Coordinate Projection** [Green Checkmark]

Name	Source
USA/NAD83/KY North	Carlson
USA/NAD83/AL West	Carlson
USA/NAD83/AK II	Carlson
USA/NAD83/CA 6	Carlson
USA/NAD83/CO North	Carlson

Delete | Add Predefined

View | Add User Defined

- **Projection:** If you click the arrow to the right of the current projection, you can select from a list of projections that you have previously created. But to select a projection that you haven't previously used, choose **Edit Projection List**.
- **Convert WGS84 to NAD83.** Most base stations in North America broadcast NAD83 positions. Topcon Base Reference networks sometimes are configured to use WGS84. Turn this option on when a North American base station is transmitting WGS84 positions. Leave this option off for all other situations.



- **Edit Projection List:** Click this button to select a predefined projection or define a new projection.
- **Add Predefined:** If you click **Add Predefined**, you can set the country/projection to use at the top of the dialog, then choose the zone within the projection. For example, in the United States, State Plane 83 is a common projection, with various grids available covering all states. If Austria is selected, options for that country appear. Predefined coordinate systems are not editable.

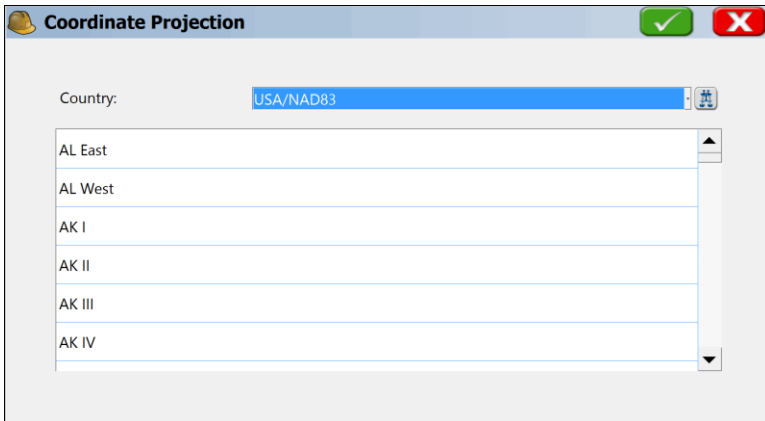

- **Country:** Some of the projections available for selection in the Country category are discussed below:

**NAD 27:** When selecting this coordinate system, you will also need to specify a state plane zone. SurvPC will use data files to perform a NADCON datum shift from WGS84 to NAD27 coordinates. By default, only data files for the continental U.S. are loaded with the software. If you are working outside this region, please load the appropriate files from your CD to the SurvStar\NADConv directory. NAD27 uses the Clarke 1866 ellipsoid.

**NAD 83:** When selecting this coordinate system, you will also need to specify a state plane zone. NAD 83 uses the GRS80 ellipsoid. If you choose the option, another NAD83 Zone selection dialog will be shown to the user. The user may select the Find my Zone or Select State options to set the NAD83 zone correctly.

**UTM:** The ellipsoid used in the Universal Transverse Mercator calculation is determined by the Datum selection. If you choose the option, “WGS 84/Automatic Zone Selection”, the zone is determined by the lat/lon values read in from the receiver. If you know your UTM zone, you can also select it. Whenever SurvPC does a reverse calculation (from UTM to WGS84) you will be prompted to enter a zone number.

**3TM (Canada):** This system is also referred to as “MTM”. It is a 3 degree zone width Transverse Mercator calculation. You may select between the Clarke 1866 ellipsoid and the WGS84 ellipsoid.



**New Zealand:** You may select between “NZGD2000” and “NZGD49”. Both use the Transverse Mercator calculation. NZGD2000 uses the GRS80 ellipsoid. NZGD49 uses the International 1924 ellipsoid. You may specify a Meridional Circuit with either datum. To select the circuit, press the Define button. You will see a pull-down list with all Meridional Circuits as well as the option to pick None.

**RGF 93 (France):** This system requires that you have the file named “Predefl.csl” in the SurvStar director. If this file is not found, please re-install SurvPC.

**NTF (France):** This system requires that you have the file named “Predefl.csl” in the SurvStar directory. If this file is not found, please re-install SurvPC. NTF is an approximation of the NTF-GR3DF97A grid transformation.

**NTF-GR3DF97A:** This system is a grid transformation that requires the files “Predefl.csl” and “gr3df97a.bin” to be in the SurvStar directory. The “Predefl.csl” file is part of the default installation. You will need to use Data Transfer to copy the “gr3df97a.bin” file from your CD to your PC.

**OSTN02 (UK):** This system is a grid transformation that requires the files “Predefl.csl”, “ostn02\_x.bin” and “ostn02\_y.bin”. The “Predefl.csl” file is part of the default installation. You will need to use Data Transfer to copy the “ostn02\_x.bin” and “ostn02\_y.bin” files from your CD to your PC.

**RD2000:** This is the RD NAP transformation for the Netherlands. This system is a grid transformation that requires the file “Predefl.csl”, “X2C.grd” and “Y2C.grd”. The “Predefl.csl” file is part of the default installation. You will need to use Data Transfer to copy the “X2C.grd” and “Y2C.grd” files from your CD to your PC.

**Denmark 34:** Used for all cadastral mapping and for most technical mapping carried out in Denmark. System 34 is a two dimensional - horizontal - coordinate system. System 34 is based on the National Geodetic Reference Network and is divided into two different zones, one covering Jutland and Fuen, and the other covering Sealand. The island of Bornholm has its own coordinate system called System 45.

- **Add User Defined:** To define a new coordinate system, go to the Localization under the EQUIP tab. You will find the **Edit Projection List** button under the SYSTEM tab. Then select the **Add User Defined** button. Enter a name for your system (e.g. PRVI for Puerto Rico/Virgin Islands), then select a projection (in the example below, Lambert\_Conformal\_Conic\_2SP) and enter the appropriate parameters. Note that all latitude and longitude values are in decimal degrees and False Northing and False Easting are always presented in meters. All entries involving degree must be in decimal degrees based on a 360 circle.

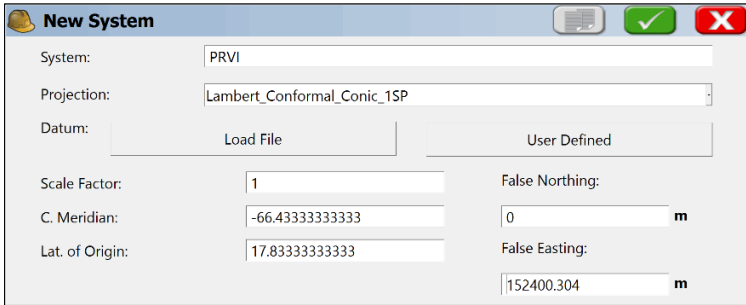

**New System**

System: PRVI

Projection: Lambert\_Conformal\_Conic\_1SP

Datum: Load File User Defined

Scale Factor: 1 False Northing: 0 m

C. Meridian: -66.433333333333 0 m

Lat. of Origin: 17.833333333333 False Easting: 152400.304 m

**User Defined:** You may select a predefined Ellipsoid or set your own parameters by typing in a new ellipsoid name and entering values for a and 1/f. The values for dX, dY, dZ, rot X, rot Y, rot Z and scale are “to WGS84”. SurvPC will support up to 10 decimal places when saving the projection scale factor.

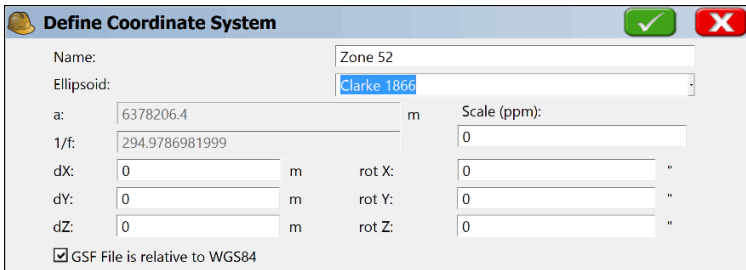

**Define Coordinate System**

Name: Zone 52

Ellipsoid: Clarke 1866

a: 6378206.4 m Scale (ppm): 0

1/f: 294.9786981999

dX: 0 m rot X: 0 "

dY: 0 m rot Y: 0 "

dZ: 0 m rot Z: 0 "

GSF File is relative to WGS84

If the values you have are “from WGS84”, simply reverse the sign of each value (positive becomes negative and vice versa). You will need to save the system to a file. You may save the system to a “.sys” file or a “.csl” file. Sys files contain only one system definition. Csl files contain multiple system definitions. Both files are ASCII text files using OpenGIS WKT (Well Known Text) format.

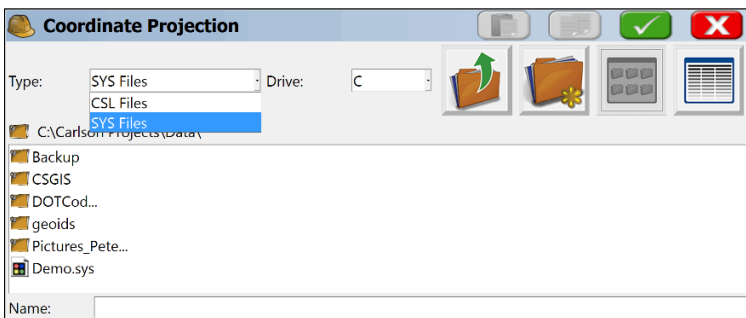

**Coordinate Projection**

Type: SYS Files Drive: C

Files: SYS Files

C:\Carlson\Projects\Data\

- Backup
- CSGIS
- DOTCod...
- geoids
- Pictures\_Pete...
- Demo.sys

Name:



**Load File:** To load a user-defined coordinate system from a file, Click under the Edit Projection List button under the SYSTEM tab in Localization. Select Add User Defined and then Load File. Change the File Type at the top to “.sys” or “.csl” depending on the type of file you are loading. A “.sys” file will be associated with each job. You can load the projection last used on a survey job by loading its “.sys” file. Select your file and hit OK. If you have selected a “.csl” file, you will be asked to choose from a list of system definitions found in the file. For the “.csl” type, you may verify that the details of your system have been loaded correctly by clicking the edit option.

## TS Tab

The TS tab is where you specify the total station scale and adjustment options.

The screenshot shows the 'Localization' window with the 'TS' tab selected. The window has a title bar with a green checkmark and a red 'X' button. Below the title bar are tabs for 'System', 'TS', 'GPS', 'Points', and 'By Helmert'. The 'TS' tab is active. The main area contains several options:

- Curvature & Refraction
- Sea Level Correction
- Use Ground to Grid: 1.000000000000 (with a calculator icon to the right)
- Automatic scale to grid

Below this is a sub-window titled 'TS Ground To Grid' with its own title bar and buttons. It contains the following fields:

- Method: Average Points (with a dropdown arrow and a  $\Sigma/n$  icon)
- N: [empty field]
- E: [empty field]
- Z: [empty field]
- Grid Factor: 1.000000000000
- Height Factor: 1.000000000000
- Combined Factor: 1.000000000000

- **Curvature and Refraction:** This option applies only to total station configurations and will be unavailable when your instrument is configured to any GPS option. This factor causes an adjustment in distance measurement. Effects are negligible except over long distances. It is recommended that this toggle be enabled, except in those cases where the instrument factors in curvature and refraction.
- **Sea Level Correction:** If the sea level correction toggle is enabled (Use Ground to Grid is clicked off), the horizontal distance at the source point's elevation is reduced to the sea level chord using the mean height of the vector. Typically, this value is negligible unless measuring very long distance.
- **Use Ground to Grid (Scale Factor):** If clicked on (as above), then you can automatically calculate the Ground to Grid factor. For most applications, the Ground to Grid Scale Factor for total station work should be set to 1.0. This uses the actual measurements from the total station for all distances. However to convert total station ground measurements to match GPS measurements, the





ground to grid scale factor can be computed (or hand-entered) by clicking the "Calculate" icon . This leads to the dialog at right (above). A local coordinate and average height can be entered or recalled from the list of points or from the map screen. This will compute the grid factor (from the projection) as well as the elevation factor to produce the combined grid/elevation factor that reduces ground distances to grid. Therefore, for total stations, the scale factor acts as a multiplier. All distance measurements taken by a total station will be multiplied by the scale factor. Because there are two potential uses of the scale factor (to adjust GPS measurements and to adjust total station measurements), two distinct scale factors are stored and recalled for any job, one for total stations located on the TS tab and one for GPS located on the GPS tab.

- Average Icon:** The summation  or "averaging" icon at the top of the dialog can be used to get an average height and coordinate position from a range of points when average points as a method is selected. Here is an example where 5 points were used to create an "average" combined factor. This feature recognizes the different elevation impacts of metric versus English units. Be sure that the selected points have correct, non-zero elevations, or scroll right to the V On column and turn Vertical off for purposes of averaging.

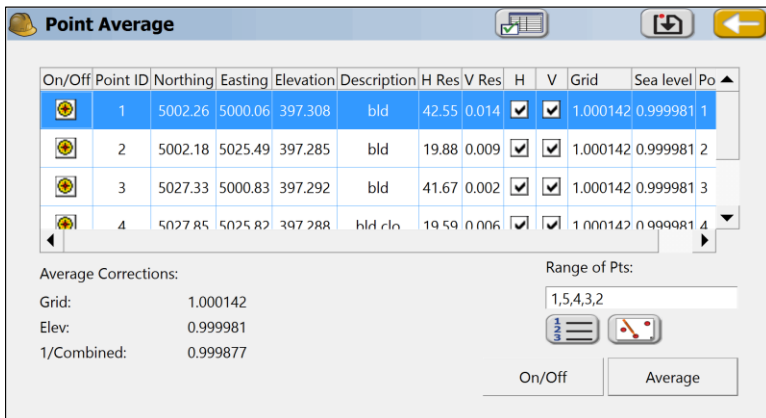

On/Off	Point ID	Northing	Easting	Elevation	Description	H Res	V Res	H	V	Grid	Sea level	Po
	1	5002.26	5000.06	397.308	bld	42.55	0.014	<input checked="" type="checkbox"/>	<input checked="" type="checkbox"/>	1.000142	0.999981	1
	2	5002.18	5025.49	397.285	bld	19.88	0.009	<input checked="" type="checkbox"/>	<input checked="" type="checkbox"/>	1.000142	0.999981	2
	3	5027.33	5000.83	397.292	bld	41.67	0.002	<input checked="" type="checkbox"/>	<input checked="" type="checkbox"/>	1.000142	0.999981	3
	4	5027.85	5025.82	397.288	bld	19.59	0.006	<input checked="" type="checkbox"/>	<input checked="" type="checkbox"/>	1.000142	0.999981	4

Average Corrections:

Grid: 1.000142  
 Elev: 0.999981  
 1/Combined: 0.999877

Range of Pts: 1,5,4,3,2

On/Off Average

- Calculate:** With Calculate turned on within the "TS Ground to Grid" dialog (at right), the Grid Factor is automatically multiplied by the Sea Level Factor to produce the Combined Factor. With Calculate turned off, you must directly type in the desired Ground to Grid Factor.

*Note: The grid projection selected will even impact adjustment of total station traverses and sideshots. Although the grid projection (e.g. KY North, NAD 83) is typically only associated with GPS, the projection selected will impact adjustment of raw traverses. In the command File, Raw Data, when Process No Adjust or any adjustment routine is selected (e.g. Compass Rule), the option to "Reduce to Grid Coordinates" can be selected. This will compute the combined scale factor at each endpoint of a traverse or sideshot, and then take the average combined scale factor and apply it to the measurement. Similarly, curvature and refraction can be applied as well. In this way, traverses from one known grid coordinate to another will achieve more accurate closures. It is not uncommon for traverses of considerable length and change in elevation to*



improve in closure from, for example, 1:10,000 to 1:100,000 with the application of both options. So, the use of projections applies not only to GPS but to total station raw data processing.

**Process Raw File** [✓] [✗]

Total Station | Proj. | Redundancies | Other

Reduce to Grid Coordinates

Scale: 1,00000000 ft

Apply Curvature Refraction

Starting Point: 1

Ending Point: 31

## GPS Tab

The GPS tab is where you define the Localization methods, geoid file, and GPS scale factor.

**Localization** [✓] [✗]

System | TS | **GPS** | Points | By Helmert

Base Translation by Rover Readings

Localization Method

Multi Point Method: Plane Similarity

One Point Azimuth: State Plane Grid

Geoid File: None

Geoid Interpolation Method: Quadratic

Use Grid to Ground: 1.000000000000 [T] [G]

---

**Localization** [✓] [✗]

System | TS | **GPS** | Points | By Helmert

Base Translation by Rover Readings

Localization Method

Multi Point Method: Plane Similarity

One Point Azimuth: State Plane Grid

Geoid File: None

Geoid Interpolation Method: Quadratic

Use Grid to Ground:



**Figure 2: No Localization File (Upper Image),  
Multi-Point Localization File (Lower Image)**



- **Multi-Point Method (Transformation Types):** The transformation can be by plane similarity, rigid body, or seven-parameter Helmert methods. Plane Similarity and Rigid Body both use a best-fit least-squares transformation. The difference is that the rigid body method does a transformation with a translation and rotation, without scale. The plane similarity does a rotation, translation and scale. These two methods only apply when two or more points are held horizontally in the points tab. The Helmert method requires the user to enter the seven parameters on the By Helmert tab.

The screenshot shows a dialog box titled "Localization" with a green checkmark and a red X icon in the top right corner. The dialog has five tabs: "System", "TS", "GPS", "Points", and "By Helmert". The "By Helmert" tab is selected. The dialog contains the following fields and buttons:

System	TS	GPS	Points	By Helmert
dX:	0	m	rot X:	0
dY:	0	m	rot Y:	0
dZ:	0	m	rot Z:	0
Scale (ppm):	0			
Calculate from Points				
Output to Text File				

- **One Point Azimuth (North Type):** This option applies to the rotation when using one-point localization. For this alignment method, the grid coordinate is translated to the local coordinate. Then the rotation can use either grid north or geodetic north.
- **Use Grid to Ground (Scale Factor for GPS):** The Read GPS and Calculation options do not appear for multi-point localizations. In that case, the scale factor is fixed by the localization itself. When only 1 point is used for localization (for a translation), or no points are used in the localization file (position is derived from the reference station GPS), then you have the option to set a grid to ground scale factor. Icons allow you to "Read from GPS"  to auto-calculate the Grid to Ground factor or more formally calculate the Grid to Ground factor using the Calculate Icon . For most applications, the Grid to Ground factor (scale factor) should be set to 1.0 to work on the grid coordinate system using GPS. The combined scale factor represents the "combined" grid/elevation factor that reduces ground distances to grid. Therefore, for GPS, the scale factor would be the reciprocal of the standard combined scale factor, taking you from grid to ground. The example below presents the options that appear when **Calculate** is selected. A coordinate is used to obtain the grid factor, and an average elevation is used to obtain the sea level factor. The combined factor is then computed. Since this combined factor is "ground to grid", the reciprocal is taken to obtain the "grid to



ground" scale factor. Since the scaling must be based on a "scale point", it is necessary to enter the scale point in the lower portion of the dialog shown below. The scale point can be entered, you can take a GPS reading, or it can be set to the single point in the Localization file.

**GPS Grid To Ground Scale**

Method:

N: -816606.4143ft    E: -1623041.3077ft    Z: 397.320ft

Grid Factor:

Height Factor:

1/Combined:

Scale Point

Point Id:                    N: -816606.414                    ft    E: -1623041.308                    ft

set by Average Points                   

---

**Point Average**

On/Off	Point ID	Northing	Easting	Elevation	Description	H Res	V Res	H	V	Grid	Sea L
<input checked="" type="checkbox"/>	1	-816650.41	-1623141.21	397.331	bld	109.16	0.011	<input checked="" type="checkbox"/>	<input checked="" type="checkbox"/>	1.007139	0.995
<input checked="" type="checkbox"/>	2	-816644.51	-1623116.44	397.308	bld	84.24	0.012	<input checked="" type="checkbox"/>	<input checked="" type="checkbox"/>	1.007139	0.995
<input checked="" type="checkbox"/>	3	-816625.84	-1623146.36	397.316	bld	106.83	0.005	<input checked="" type="checkbox"/>	<input checked="" type="checkbox"/>	1.007138	0.995
<input checked="" type="checkbox"/>	4	-816619.46	-1623122.16	397.311	bld	81.90	0.009	<input checked="" type="checkbox"/>	<input checked="" type="checkbox"/>	1.007138	0.995

Average Corrections:

Grid: 1.007138

Elev: 0.999981

1/Combined: 0.992931

Range of Pts:

Within the Calculate option, using the method Read GPS obtains the coordinates to be used for scaling and for the scale point. Alternately, you can enter the coordinates, pick them from a list, or select from the map. In GPS, the Scale Factor (1/Combined) is applied to the distance between the coordinate and a base point. The coordinate is then set by starting from the base point and moving in the direction to the coordinate for the adjusted distance.

You can click the "Summation" icon at the top of the dialog and obtain the combined factor from an averaged selection of points. The combined factor, always "Ground to Grid", will then be inverted and displayed as 1/Combined to represent "Grid to Ground". In the form of 1/Combined, it acts as a multiplier to scale all GPS measurements from the Scale Point.



- **Geoid Separation File:** This option will incorporate the geoid undulation in determining the orthometric elevation of the measurement. The definition of the geoid model as currently adopted by the National Geodetic Survey is the equipotential surface of the Earth's gravity field which best fits, in a least squares sense, global mean sea level. Orthometric elevation measurements are used in survey calculations. In order to convert ellipsoid heights ( $H_e$ ) as measured by GPS into orthometric elevations ( $E_o$ ), you must provide for a correction between the GPS-measured ellipsoid (reference ellipsoid) and a constant level gravitational surface, the geoid. This correction is the geoid undulation ( $U_g$ ). SurvPC has preinstalled the US and Canadian geoids. Use XPort or SurvCOM to download the Geoid Separation File. This option only has significant impact with one-point or no-point (reference station-based) alignments. The zip file containing the Geoid Files (GSF, Geoid99 or EGM) is found on the SurvPC installation CD, and a portion of any such file can be specified (by size and center point) for downloading to the data collector using Carlson X-Port or Carlson SurvCom. SurvPC allows binary \*.grd geoids and standard \*.gsf geoids. Geoid files will be backed up in the backup folder. If geoid files are lost, they will be automatically restored from backup.

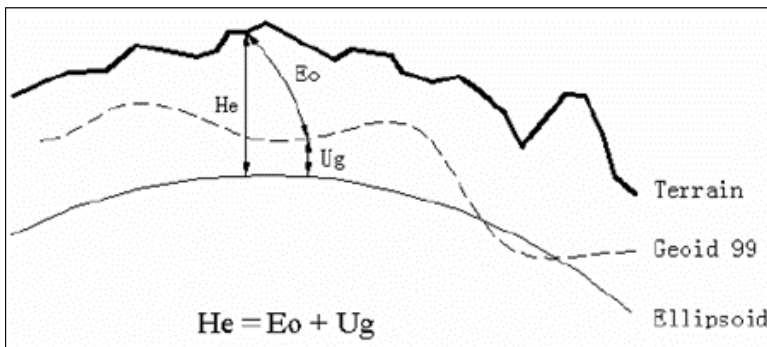

- **Geoid Interpolation Method:** Three methods are provided: Quadratic, Bilinear and Bi Cubic Spline. The default setting is Quadratic.

### How to Use Geoid Files with Carlson SurvPC

*The US and Canadian Geoid files are part of the Carlson SurvPC 6.0 Install*

1. Download and/or install either Carlson X-Port or SurvCOM to the desktop computer.
2. Download and/or install "CarlsonGeoidGrids.exe" to a location on your desktop computer (Typically installed to the "...\Program Files\Carlson X-Port" directory).
3. Run Carlson SurvPC and select **Data Transfer** from the FILE tab.
4. From within the **Data Transfer** dialog, select the **Carlson Civil/Carlson Survey Transfer** option.



5. Launch either Carlson X-Port or SurvCOM from your desktop computer. If you are using Carlson X-Port, select **Carlson SurvPC** from the **Tools** menu to launch SurvCOM.
6. Select the **Geoid** icon located at the bottom of the **SurvCOM** dialog.
7. From within the Set **Geoid Area** dialog, verify the path to the geoid files is set to the installed location of these files as defined in step 2 of this document (Typically "...Program Files\Carlson X-Port\").
8. Select the desired geoid model to extract an area from.
9. Key in the approximate latitude and longitude of the center of the area.
10. Define the grid size for the area you want the model to cover (Supported sizes are 50-250 miles, 80-400 kilometers and 1-5 degrees, however, keep the size 100 miles or smaller for better performance).
11. Name the geoid model with any name that you want (e.g. "geoid"). You may want to name this file with a logical name for the location of the area for future reference (e.g. "geoid-LA").
12. Select the **OK** button to automatically transfer the file to the "...\Survstar\" directory of the PC.
13. Go to the FILE tab and select **Job Settings**, then choose the GPS tab.
14. Select the **Geoid Separation File** button and choose the geoid file you created and transferred with SurvCOM.
15. You have now completed the definition and selection of the geoid file. Select **OK** to exit the **Job Settings** dialog.

### Points Tab

This tab is where the user adds pairs of positions to create a localization.

Localization

System TS GPS **Points** By Helmert

Pt ID	Northing(ft)	Easting(ft)	Elevation(ft)	H Res(ft)	V Res(ft)	H On	V On
1	5002.2616	5000.0593	397.3076	0.000	0.000	Y	Y

Scale:1.000000  2pt Rotate Only

Avg HRes:0.0000 Avg VRes:0.0000

Add	Delete	Edit	On/Off
Load	View	Monitor	Save

- **View:** The local coordinates are shown in the POINTS tab by default. Pressing View will switch the view to show the geodetic, Lat/Lon coordinates.
- **Scale:** The Scale Factor, shown in the Localization dialog when two or more localization points are used, is a multiplier and represents "grid to ground". When configured to GPS in release 1.50.004 or higher of SurvPC, any GPS localization scale factor is displayed within the UNITS tab of Job Settings in inverse form to represent "ground to grid".



- **Add:** Enter the alignment or localization points by coordinate values or by entering a point number. If you choose the point number method, you can enter a point number or select them from the point list. If you choose the From List method, you can access points in the Control File, if a Control File is active (See Job Settings, Options). You can average as many readings as you like when you add points, and view the range and residuals. It is recommended that you use the point number option and carefully hand-enter your local grid system coordinates first, using either List Points, option Add, or Keyboard Input. Entry of coordinates “on-the-fly”, in the field, provides opportunity for error. Once you click OK in the coordinate dialog, you will have three options for establishing the GPS position for the named local point.

**Local Point** [Green Checkmark] [Red X]

Please enter local coordinate values. You may use a point ID from the current or control job.

Point From File:  [Dropdown] [Search]

Local Northing:  ft

Local Easting:  ft

Local Elevation:  ft

**Add Method 1 – Read GPS:** This allows you to collect measurements from the GPS receiver and average as many readings as you choose. Once the readings are complete, the software will present a dialog that displays the range and residuals of average readings.

**Add Method 2--Enter Local Latitude/Longitude:** This allows you to hand-enter known geodetic coordinates for the local position. The elevation should be the ellipsoid elevation in the current job units if a geoid model is not applied. If a geoid model is applied, then the elevation should be the orthometric elevation in the current job units. This method allows manual entry of a localization file without occupying points in the field. Note that you do not enter the decimal point for decimal seconds.

If you use manual entry of a localization data set, it is important that you either utilize an existing base GPS receiver with the fixed antenna location that was used to survey the original geodetic positions, or that you set up your base on a known GPS position measured previously using that localization data set. Good survey practice would include checking into known positions to verify the quality of your hand-entered GPS localization and verifying low residuals in the Localization screen. With all data pairs used for both horizontal and vertical control (none turned off), the resolutions for this data set will appear.



**Add Method 3 - Point from Raw File:** This allows you to use a point from the raw data file that has been previously collected via GPS. This is just like Read from GPS except you are recalling a point previously measured and stored in the raw file. For this to work, you must have the base antenna in the same position as when the original raw file was collected, or you need to set your base antenna over a known coordinate from the original survey, and enter those original coordinates and the new base antenna height within the command Configure Base.

- **Delete:** Allows you to delete the selected item from the list. Note that it is not necessary to delete a localization point if you simply want to avoid using it. You can disable both the horizontal and vertical component of the point, but keep it available for use later.
- **Edit:** Allows you to edit the selected item in the list. It will display the northing, easting and elevation of the localization point, which can be changed.
- **On/Off:** Allows you to remove the horizontal or vertical components of your localization points. This is a frequently used feature that enables the use of one point for vertical control only (turn off its horizontal component) and other points for horizontal control (turn off their vertical, if appropriate). Points with no known elevation (0 for example), would obviously be used only for horizontal control, as shown in this example.

The screenshot shows the 'Localization' window with the 'Points' tab selected. The table below contains one data row:

Pt ID	Northing(ft)	Easting(ft)	Elevation(ft)	H Res(ft)	V Res(ft)	H On	V On
1	5002.2616	5000.0593	397.3076	0.000	0.000	Y	Y

Below the table, the scale is set to 1.000000 and the checkbox '2pt Rotate Only' is unchecked. Statistics show 'Avg HRes:0.0000' and 'Avg VRes:0.0000'. At the bottom, there are buttons for 'Add', 'Delete', 'Edit', 'On/Off', 'Load', 'View', 'Monitor', and 'Save'.

*Note that in this example, it takes three horizontal control points, active "H On = Y" to get horizontal residual results, and four vertical control points, active "V On = Y" to get vertical residual results. You can employ trial and error to remove different points from consideration both vertically and horizontally and watch the residuals of the remaining control points improve or degrade. In this way, if you have four or more total control points, you can determine the best combination to use as horizontal and vertical control.*

- **Load:** This allows you to load any localization file for modifying or for the purpose of associating it to the current job. Note that the **OK** button must be used if the intention is to associate the loaded file to the current job.
- **Monitor:** Goes to the standard Monitor screen. This is particularly useful to verify the quality of your satellite coverage and your fixed or float status. You





always want the best possible fixed status when conducting a rover-based localization.

- **Save:** Allows you to save the control points in a file.
- **2 pt Rotate Only:** Allows you to use the second point in the localization file for direction but not for scaling. In this case, any scale factor set on the UNITS tab in **Job Settings** would be active.
- **OK:** Pressing **OK** will temporarily recall the current Localization as you work. If you change the Localization file, Save, then Cancel, the original Localization file will still be active. Pressing **OK** is what makes it active, and current. In this case, you would need to Load the new Localization file and press **OK** to make it active. You can choose to **Add** localization points midway on a job, and not actually use them by pressing **Save**, then **Cancel**. Then when the job is complete, you can recall the Localization file with all the old and added localization points, go to **Process Raw File**, and re-calculate all surveying points according to the new Localization.

### Discussion of Localization Techniques

If you do a base localization by entering Latitude and Longitude or known coordinates on the designated coordinate system, then you do not need to add localization points. A base localization would put you on grid north and grid scale and would work for any new job where you are not trying to match existing coordinates. However, any time you are working on a project that has existing coordinates, you will most likely need to do a Localization. Even if that existing job is supposedly on state plane, UTM or another known coordinate system, the project coordinates often fail to match grid scale and grid north exactly, requiring localization. When localizing, it is advisable to use at least three points for horizontal control and four points for vertical control, in order to get a measure of residuals (or accuracy). The program will “best fit” a plane through all activated (H=On and/or V=On) control points. The residuals are how much each activated point is off of the plane surface. Because multiple elevation points may create a slightly tilted plane, some surveyors will verify that the vertical control has low residuals and is accurate using multiple vertical control points, then turn off all but one (V=Off) and use only the nearest vertical (elevation) as they progress through the job.

*Note: The Scale Factor chosen in UNITS under Job Settings will cause all GPS measurements to be adjusted by the scale factor. For GPS, scale factors can only be entered for one-point localizations (base or rover). For multi-point rover localizations, the scale factor is computed by the localization and fixed. It appears grayed out under UNITS in Job Settings. When a scale factor is used for one-point localizations, scaling occurs along the vector outward from the single localization point in the direction of the measured point. For GPS, the scale factor acts as a divisor. A scale factor of 0.9 will calculate the measured point 1/0.9 units further away from the single localization point. Therefore, it is recommended that you keep the scale factor set to 1.0. When configured to total station, the scale factor is sometimes used to go “ground to grid”. When configured to GPS, the scale factor in is sometimes used to go “grid to ground”, to better match total station scaling. The scale factor is defined as “ground to grid”. To go “ground to grid” from high elevations, for example, it would be less than 1. It would multiply total station measurements and reduce them to grid. It would divide GPS measurements and expand them to ground. If your goal is to work on the specified state plane, UTM or other grid coordinate system, and you are planning to use a one-point localization, then the scale factor should be set to 1, unless you are trying to match “ground” coordinates, where the coordinates are “true north” but not “true scale”. In all other cases, matching ground coordinates with GPS is best accomplished with a multi-point rover-based localization. The resulting “effective” scale factor multiplier will appear in the localization screen, such as the 0.999779 value shown in the last figure.*



After a change in a localization file, any points measured in the field by GPS will be converted from Lat/Long to local coordinates by using the new localization file. For this reason, it is a good idea to re-convert older GPS measurements to the same, compatible coordinate system by going to **Process Raw Data**, option **Process GPS**, within the COGO tab.

### Geoid Files

The Geoid file is loaded onto SurvPC using Carlson X-Port. You first select the area of interest, then X-Port “carves out” the geoid for that area and downloads it to SurvPC. You set the Geoid file in the EQUIP tab in the main menu and then tap **Localization**. In the Localization routine, tap the **GPS** tab and then tap the **Geoid File** button. The Geoid should be used principally with one-point localizations. Starting with a known position for the base (or using a one-point rover localization and approximate base position), the program will add or deduct the geoidal separation from the computed Z value on all measurements, and will match more closely to geoid-based surface elevations. The Geoid can also be used with multiple-point rover localizations, since the added accuracy provided by the geoidal calculation can reduce vertical residuals. This is true, however, only if the points being matched had Z values that, themselves, considered the geoid. Since you will get a best-fit plane that minimizes vertical residuals with or without use of the geoid, it is often not used with rover-based localizations.

### Changing or Updating the Localization File

There are two ways to change a localization file. One method is to edit an existing file by deleting elements, and the second is to add additional localization points. In either case, whenever a change in the “.dat” localization file is detected, you are prompted whether you would like to re-process any previously stored GPS points found in the raw file. The dialog below appears.

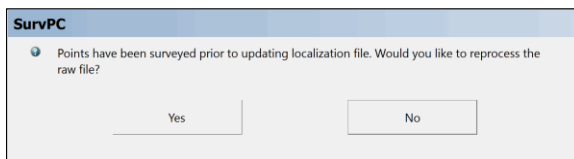

If you answer **Yes**, you will be directed to the **Process GPS** command found within **COGO, Process Raw File**.



## Recalculating Stored GPS Points

There is no requirement to survey all localization points first, unless you are doing stakeout. For simple topo or data gathering, you can set up your base, survey in one or two localization points with the rover, then gather data in **Store Points** as needed. As you move cross country and encounter another known, or unexpected, control point, you can localize on it and add it to the list. The next step would be to verify residuals, and if the results are good, you can reprocess the raw file and keep your entire survey fully updated. If the residuals are disappointing, you can choose not to include the new point in the localization file. Either remove it or turn its H and V components off. You can also choose **Process Raw File** to recalculate all GPS measurements at any time.

## Including the Base Position in the Localization File

To use the base in the localization, you should configure the base with the **Use Local Coordinates** option under **From Known Position**. Here, you configure the base by entering the local point (5000,5000,100, etc.) and start a new localization file (or use an existing one if it applies). Then, at your rover, you can add more points to the localization as necessary.

## Localization and the Raw File

If the scale for GPS is determined from the localization, a “GPS Scale” record of 1.0 and a “Localization Scale” equal to the calculated scale appearing in the Localization screen will be written to the RW5 file.

## Using the Localization File to Improve Base Localizations through Logging Static Data

The Localization File (.dat) typically applies to rover-based localizations. But if you did a **Read GPS** on your base antenna position and then took GPS shots with no rover localization and logged static data on the base in the meantime, it is possible to submit that logged information to the OPUS program and obtain an accurate base position. At this point, it is still possible to recalculate all the field shots taken earlier from the less accurate base. To do so, follow the procedure outlined below.

1. Store the Base Point (Reference Tab in the Monitor screen).
2. Add a point to the now-empty Localization File. For the local point, enter the grid system coordinate computed by OPUS or another program. For the geodetic Lat/Lon point, review the raw file and select the point you stored for the base.
3. Reprocess the raw file through the localization. All CRD points should then be relative to the new calculated (e.g. OPUS-generated) coordinate.



## 5.13 Monitor / SkyPlot (GPS)



The Monitor/Skyplot command allows you to review local position and quality of data.

- **Quality:** Under the QUALITY tab you monitor the status and number of satellites. You can also review the horizontal and vertical RMS values, as well as HDOP, VDOP, PDOP, TDOP and GDOP values. Some instruments refer to RMS values as CEP and SEP. For the CSI DGPS and the Sokkia Axis 3 receivers using OmniStar, the BER value will be shown in order to give indication of the strength of corrections received. When set to CSI DGPS, the age of corrections is also displayed. If connected to a network, the Base Selection will be shown. The number of satellites (SATS) is shown.

Monitor / Skyplot				
Quality	Position	SATView	SATInfo	Ref
Status:	FIXED(Sim)		Satellites:	14
			Local Elev:	397.3249ft
Local Northing:		4914.1163ft		03/27/2017
Local Easting:		4795.7179ft		14:24:16.0
HDOP:	2.90	VDOP:	3.80	
TDOP:	2.00	PDOP:	3.20	
GDOP:	3.77			
HRMS:	0.030ft			
VRMS:	0.039ft			

The Status is shown as either:

**AUTONOMOUS:** No radio communication between base and rover.

**DGPS:** Corrections from differential sources such as WAAS or SBAS.

**FLOAT:** Communication has been established, but ambiguities have not been resolved.

**FIXED:** Position has been resolved.



- **Position:** Under the POSITION tab you see the current position given in latitude, longitude, ellipsoid elevation, geoid separation, and orthometric elevation. You will also see the local grid coordinates here.

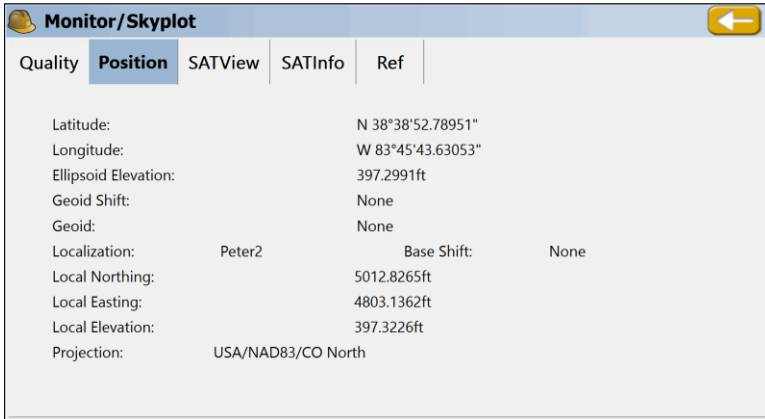

- **SATView:** Under the SATView tab, the spatial orientation of the satellite constellation is shown. You can also see if the satellite is rising or falling in the sky, by the associated arrow. Click on any satellite number to see individual satellite details, including the precise signal/noise ratio. You can also toggle satellites on and off if supported by the GPS. If a satellite is turned off, it displays with a line through it within the Signal/Noise Ratio graphs.

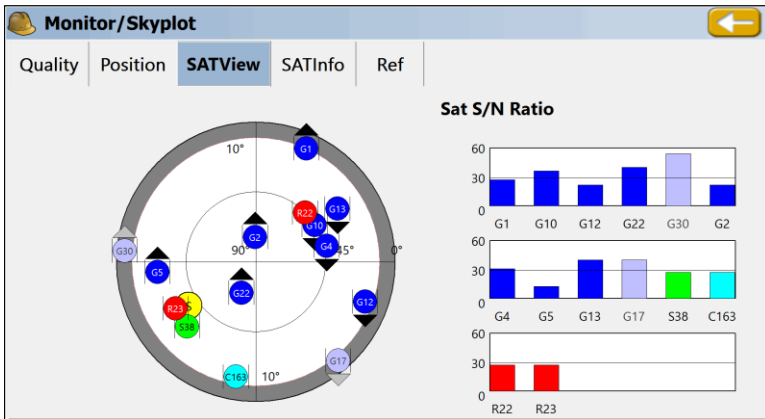



- **SATInfo:** This tab shows information on Satellites.

**PRN** is the satellite reference numbers. \* indicates satellite in use for position calculation.

**AZI:** is the satellite azimuth.

**ELV:** is the satellite elevation above the horizon, including rising (>) and falling (<) direction. The "\*" designation indicates that the satellite is used in the calculation of position.

PRN	AZI	ELV
G1*	24°	10° >
G10*	58°	45° <
G12*	110°	15° <
G4*	77°	43° <

- **Ref:** The REF tab to the right of SAT Info appears with most GPS configurations (not with GPS Simulation). The REF tab will show the base station information stored to the reference file, which is created during base configuration. The Magellan/Ashtech GPS, for example, will show the distance from rover to base. The base coordinates can also be stored by pressing the Store button. You simply enter a point number and description, and the precise base coordinates are stored in north, east and elevation, according to the localization file settings. Then the base coordinate point can be used for total station work as a setup or backsight. If a base position of 0,0,0 is detected, representing in invalid base setup, the Store button will be grayed out. If the driver does not specify the type (ARP/APC) of the reference elevation when provided by the rover, SurvPC will make the assumption that if the correction type is RTCMv3, the elevation is ARP.

Reference Station Coordinates	
Latitude:	N 42 21'41.71900"
Longitude:	W 71 09'53.46860"
Ellipsoid Hgt:	0.0000
Antenna Type:	5.250 ASH110454 (69.4mm)
Distance to Ref:	4670.6856
Northing:	2956910.0449
Easting:	746745.6866
Elevation:	21.3668
Ant Hgt:	2.000

Buttons: Store, Antenna



## 5.14 Mission Planning



SurvPC includes Mission Planning. This option is found by clicking on the helmet within the Monitor/Skyplot screen, as seen in the figure below.

*Note: Mission Planning is also available in Equip – GPS Utilities – Mission Planning as well.*

Mission Planning can help select the best times for field surveying to ensure accurate real-time kinematic (RTK) data gathering using GNSS equipment. By predicting when satellites are most available, Mission Planning reduces wait time, time to fix and the likelihood of inaccurate field measurement due to poor satellite geometry. Lack of satellites is a consideration in all GNSS surveying, including static. Mission Planning can be used to select times of maximum satellite availability to conduct field work.

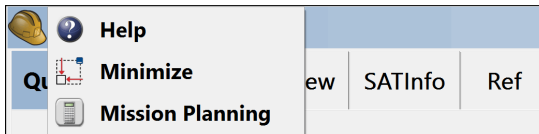

### Almanac

The almanac file contains the information of future satellite orbit positions. Select either to download the almanac file from the receiver itself or answer 'No' to the dialog to load the almanac from a previously stored '.alm' file.

In the example below, an almanac was acquired using a Trimble planning file 'current.alm'

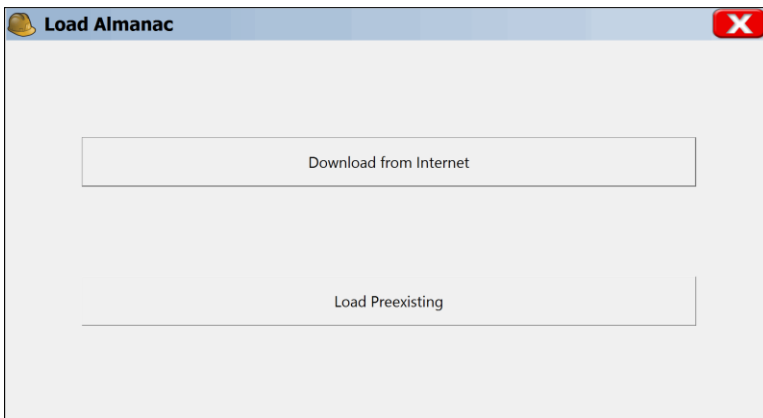

Once the preferred almanac file is loaded, the user will be presented with the Mission Planning screen. Options, or tabs, available to the user are Settings, Obstructions, Availability, and Skyplot.

Each option will be further described below.



- **Settings Tab**

The screenshot shows the 'Settings' tab of the Mission Planning software. It contains several input fields and checkboxes. The fields are: Lat: N 38°38'54", Lon: W 83°45'43", Elev Mask: 10, HAE: 397.307 ft, Start Date: 3/28/2017, Start Time: 00:00 Local, Time Span: 4h, and Time Granularity: 10m. There are four checkboxes: GPS, GLO, BDS, and GAL, all of which are checked.

In the Settings tab, the user can select the latitude and longitude of the specified location of interest (default position is the current user's position solution). The Elevation Mask, HAE, Start Date, Start Time, Time Span, Time Granularity, and satellite constellations can all be specified by the user.

- **Obstructions Tab**

The screenshot shows the 'Obstructions' tab of the Mission Planning software. It features a circular sky plot on the left and a table of obstructions on the right. The sky plot has a mask of 10.00° and shows a shaded area representing an obstruction. The table has columns for Azimuth (AZ) and Elevation (ELEV).

AZ	ELEV
1°	10°
268°	10°
270°	45°

Future satellite availability will depend on how open the sky view for signal reception will be. Obstructions play a large part in satellite signal reception and is included in the Mission Planning software package. If you have a high building or a ridge blocking satellite signal reception to your Northwest, this obstruction can be entered here. Obstructions can be entered manually or by clicking in the window on the left. In our example, there is a building blocking satellite signal reception, roughly in most of Quadrant 4, from an Azimuth of ~270 degrees to ~0 degrees at an elevation of ~45 degrees, enter in those values to update the Obstructions screen on the left.





- Availability Tab

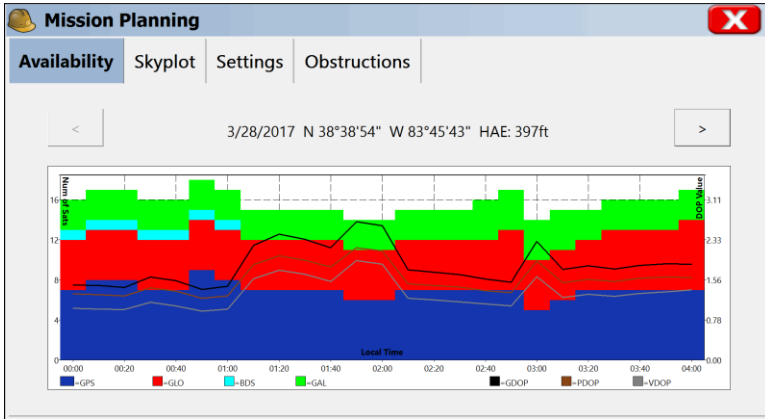

In the “Availability” tab, the vertical scale at left shows the number of satellites. The vertical scale at right shows the “Dilution of Precision” values which are graphed by 3 distinct lines for GDOP, PDOP and VDOP. The PDOP line, which is brown, is typically given the highest priority and should be less than 4 for better results. A tolerance can be set for the PDOP value reported with any measurement, and a warning would be issued prior to storing any reading above the set PDOP tolerance. This is done in the command Equip Menu, Tolerances.

For RTK surveying, where accurate readings are measured real-time in the field, it is best to have at least 5 GPS satellites available, supplemented by satellites on other constellations. If conducting a GPS-Only survey (such as under SAASM conditions), a minimum of 5 GPS satellites are required in order to fix.

Tap the right arrow key to move to the next day to review the next 24 hours of satellite availability. Use the Settings tab to specify your expected Latitude and Longitude position and to modify the duration of the view, from 24 hours to other selections like 12 hours or 6 hours. The default “granularity” of the chart in the figure above is 1/24 of the duration. So, if a 12-hour duration is used, default granularity for the bar chart is every 30 minutes. However, granularity can be revised for more narrow or wider bar chart presentation. A 10-minute granularity would lead to very narrow columns in the bar chart if covering a 24-hour period as shown above.



- Skyplot Tab

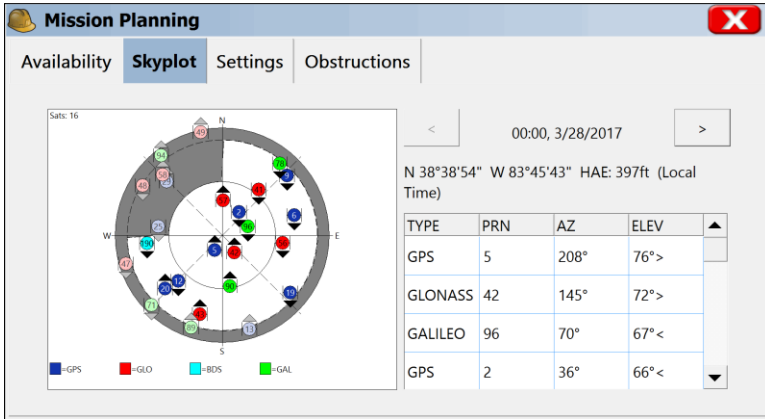

In the Skyplot tab, the user will be able to see the various satellites in view for a given time. The Time Granularity stipulated in the Settings tab allows the user to click through the Mission Planning specified time span. In the example above, the user can click right to view the satellite view in 30 minute intervals. Colors indicate both the satellite constellation (GPS = Blue, GLONASS = Red, BeiDou = Cyan, Galileo = Yellow) and tracking status. Satellites below the selected 'masking' elevation will appear lighter. The table below shows satellite status.

Satellite Constellation	Tracking	Not Tracking
GPS	Blue	Light Blue
GLONASS	Red	Light Red -or- Pink
BeiDou	Cyan	Light Gray
Galileo	Yellow	Light Yellow



## 5.15 Check Level (Total Station)



This feature is only available on instruments that provide information from electronic compensators. It allows the user to Check the level of the instrument from within the software.

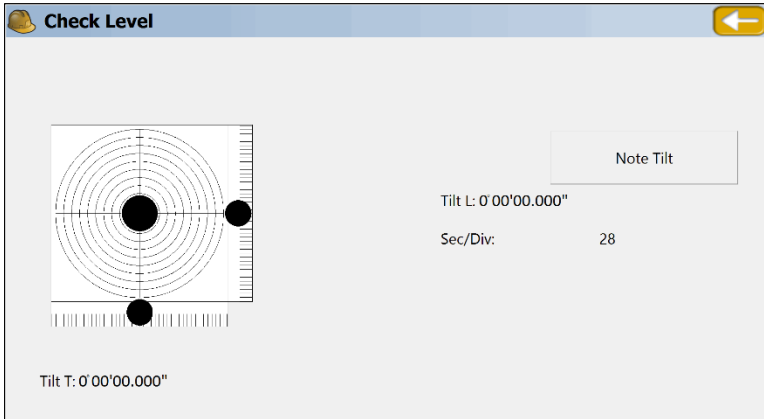

**Tilt T:** Shows the compensator value.

**Tilt L:** Shows the compensator value.

**Note Tilt:** Records values to .RW5 File



## 5.16 Tolerances



This command allows you to set operating tolerances for the collection of points. A tolerance band will show (in Red) to the user when in Live Survey Screens (Store Points / Stake Points) when the user is currently out of preferred tolerances.

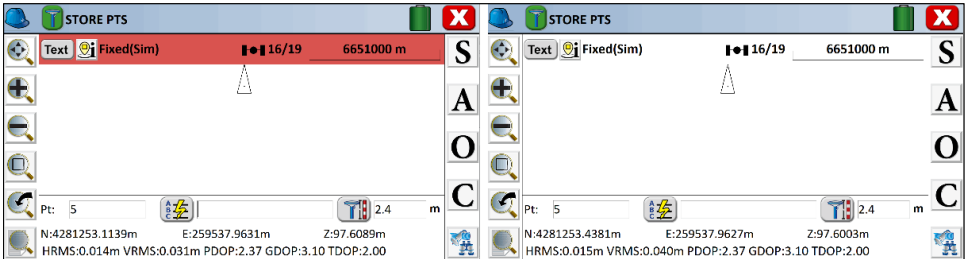



### Total Station Tolerances:

H. Obs:	<input type="text" value="0°00'30"/>	°
V. Obs:	<input type="text" value="0°00'30"/>	°
EDM Tol:	<input type="text" value="5"/>	mm
Stakeout Tol:	<input type="text" value="0.328"/>	ft
"Navigate To" Tol:	<input type="text" value="16.404"/>	ft

- **H. Obs:** This specifies the horizontal observation tolerance as an angle field. A tolerance of zero is not allowed.
- **V. Obs:** This specifies the vertical observation tolerance as an angle field. A tolerance of zero is not allowed.
- **Edm tol (mm):** EDM fixed tolerance in millimeters specifies the EDM error that is independent of the length of the line measured.
- **Stakeout Tol:** This specifies the maximum difference between the target location and actual staked point. When the staked point is beyond the tolerance, SurvPC displays a warning dialog. The Stakeout Tolerance is systematically applied to all stakeout commands. The program will respond with a warning screen such as "Stakeout is beyond the Tolerance Setting. Do you wish to continue storing?" The angle and distance tolerances are applied to multiple distance measurements (when Configure Reading specifies multiple Num Dist Readings) and when multiple angle measurements are taken in Set Collection or processed in Process Raw File.
- **"Navigate To" Tol:** This value is used when navigating to a point. Once you are near the point (the value entered), the screen will 'zoom' into your location.



## GPS Tolerances:

Tolerances  		
HRMS Tolerance:	0.050	m
VRMS Tolerance:	0.070	m
PDOP Tolerance:	3.500	
Stakeout Tolerance:	0.100	m
Proximity Radius:	1.640	m

- **CEP/H.OBS Tol:** A measurement of accuracy defined by the radius of the circle containing 50 percent of the individual measurements being made, or the radius of the circle within which there is a 50 percent probability of being located.
- **SEP/V.OBS Tol:** A measurement of accuracy defined by a sphere within which there is a 50 percent probability of locating a point or being located. SEP is the three-dimensional analogue of CEP.
- **EDM Tol:** EDM fixed tolerance in millimeters specifies the EDM error that is independent of the length of the line measured.
- **Stakeout Tol:** This specifies the maximum difference between the target location and actual staked point. When the staked point is beyond the tolerance, SurvPC displays a warning dialog.
- **Proximity Radius:** This option refers to the change from navigation mode to stakeout mode (when the target becomes a large bullseye).

*Note: CEP tolerance and SEP tolerance are only used by Trimble. All others refer to it as H.OBS and V.OBS Tolerance.*

*Note: Even if you are fixed, if you attempt to store points and your GPS tolerance values are exceeded, you will obtain a warning screen.*



## 5.17 Peripherals



A Peripheral is a device that must be used in tandem with a GPS receiver or a total station. Peripherals can all be configured from the Peripherals menu under the EQUIP tab. Lasers, Light Bars, and Depth Sounders are all supported as peripherals. If a peripheral is not currently in use, it is strongly recommended that you deactivate it, so it does not slow down other operations. Lasers such as the Leica Disto can be used for horizontal offsets and can be set to supplement the rod height for data collection “at the pole” using robotic total stations or GPS for marine or ATV surveys.

### Lasers

Currently supported lasers are Laser Atlanta, Leica Disto, Laser Impulse IP200, Laser Impulse CR400, and Sokkia Contour. If you have a different laser, contact Carlson Software to discuss adding support for it. With GPS enabled, a laser can be used to provide an offset from a GPS reading. For more information, see the GPS Offset section of the manual. With a robotic total station enabled, a laser can be used to automatically measure the rod height of each total station reading.

**Peripherals** [✓] [✗]

**Laser** | Depth Sounder | Light Bar

Active

Type: Atlanta [Comm Setup]

Auto GPS Update  Auto Laser Read

Alignment: 0°00'00" [Align Laser]

Num. Rdgs. To Avg.: 1

Laser Height: 0.000 ft  Ignore Vertical

Target Height: 0.000 ft

**Configure** [✓] [✗]

Type: Cable

Port: COM 1 [Defaults]

Baud: 9600 Parity: None

Data Bits: 8 Stop Bits: 1



To activate a laser for use with GPS, follow these steps:

1. Plug in your laser to any of your device's COM ports; make sure that it is adequately charged and turn it on.
2. Enter the **Peripherals** menu, and select the **LASER** tab, as shown above.
3. Check **Active**
4. Select the type of laser you are using.
5. Enter the height of your laser from the ground. This value will be added to the vertical offset returned by your laser. For accuracy, this value should be specified with respect to the same ground elevation that your GPS rod height was specified.
6. Directions for aligning your laser will be given in a different section. For now, leave the laser alignment value set to 0.
7. If you want GPS to be automatically updated between each laser read, enable **Auto GPS Update**. If you want the **Read Laser** button to automatically trigger the laser, enable **Auto Laser Read**.
8. Set appropriate COM port settings, by clicking on **Comm Setup**. To load the default settings for the laser you specified, select the **Default** button. However, you will still need to set your COM port number manually.
9. Click **OK** to save settings or **Cancel** to revert back to your old settings.

Activating a laser for use with a robotic total station follows a similar procedure. Attach the laser to the prism, pointing towards the ground. Every total station read will automatically trigger the laser, and the read value will be used as the rod height.

### Using the Laser

1. Once the laser has been properly set up, enter the GPS Offset method and press **Read Laser**.



2. A progress window should pop up, indicating that Carlson SurvPC is ready to read from the laser. Aim the laser and fire at a target point. Keep firing until your laser returns a valid reading, and the progress window disappears.
3. To test whether your shot was successful, verify that the values on your screen correspond to the values on your laser's internal display. Note that not all lasers return azimuth and vertical offset data, in which case this information will have to be entered manually.



## Laser Alignment

This option is only relevant to lasers with internal compasses. The purpose of this option is to allow you to compensate for any discrepancy between the laser's internal compass and the North determined by GPS. The alignment factor will be automatically added to all azimuth values returned by the laser. The alignment factor can either be entered manually or calculated using the laser and GPS. To calculate this factor using the laser, follow these steps:

1. If you don't already have two known points in your vicinity, use GPS to store two points within 50 feet of each other.
2. From the LASER tab of the Peripherals window, select **Align Laser**.

The image shows two overlapping software windows. The top window is titled 'Peripherals' and has a 'Laser' tab selected. It contains several settings: 'Active' is checked, 'Type' is set to 'Atlanta', 'Auto GPS Update' is checked, and 'Auto Laser Read' is unchecked. The 'Alignment' field is set to '0°00'00\".

The bottom window is titled 'Laser Alignment'. It has fields for 'Occupied Point' and 'Target Point', each with a list icon and a map icon. The 'Num. To Avg.' field is set to '1'. There is a 'Read Laser' button. Below these are fields for 'Alignment factor', 'Horizontal error', and 'Vertical error'. A 'Reference Angle' label is also present. A yellow arrow points from the 'Align Laser' button in the top window to the 'Occupied Point' field in the bottom window.

3. Choose an Occupied Point from your point list, and prepare to fire your laser from that point.
4. Choose a Target Point from your point list, and prepare to fire your laser at that point.
5. Click **Read Laser**, and when the "Reading Laser" progress bar appears, fire your laser at the target point from your occupied point. An azimuth reading will appear in the Laser Reading box, and two values will be calculated. The Reference Angle is the azimuth of the vector from the occupied point to the target point. The Alignment Factor is the difference between the azimuth read by the laser and the Reference Angle.
6. Press **OK**, and the Alignment Factor that was calculated will appear in the Laser Alignment box.





7. Click **OK** again to save the new alignment settings.

### **Laser-Specific Configurations**

If you're having trouble establishing communication with the laser, you may need to change certain settings on your laser's instrument panel. Here are laser-specific setup instructions for some of the lasers supported by SurvPC.

- **Laser Atlanta:** Make sure your Laser Atlanta baud-rate and message formats agree with those you specified in SurvPC. Also, make sure the laser format is set to Laser Atlanta Original (LA1KA). Consult your Laser Atlanta manual for instructions on how to do this.
- **Laser Impulse:** Make sure your Laser Impulse baud-rate and message formats agree with those you specified in SurvPC. Supported formats are IP200, and CR400. Consult your Laser Impulse manual for instructions on how to do this.
- **Leica Disto:** Make sure your Leica Disto's baud-rate agrees with those you specified in SurvPC. Consult your Laser Impulse manual for instructions.
- **Sokkia Contour:** Make sure your Sokkia Contour's baud-rate agrees with those specified in SurvPC. Consult your Sokkia Contour manual for instructions.
- **MDL LaserAce:** Using SurvPC 1.50.008 (or higher), you can use the LaserAce, but should configure your peripherals screen to Impulse (CR400). Using the MDL selection will invert the inclination. Use 9600 baud rate. Use a Topcon/Sokkia data cable (not a Nikon cable!). The laser must be configured to the same units as the job since SurvPC does not convert the measurement.



## Depth Sounders

Currently supported depth sounders are:

- Fuji PL
- Generic NMEA
- Horizon
- Hydrotrac
- Innerspace
- Navman
- Odom Digitrace
- SLD 100
- SonarMite
- SonarMite DFX

If you have a different depth sounder, contact Carlson Software to discuss adding support for it. You can use a depth sounder with GPS to map an underwater surface. When the depth sounder is enabled, SurvPC will alternate between reading from GPS and reading from the depth sounder.

*Note: If you aren't using a depth sounder, you must be sure this feature has been deactivated, or you may experience slow GPS readings.*

When active, incoming Depth readings are viewable in Monitor/Skyplot. Elevation values in the Store Point screen are automatically depth adjusted. Depth sounder records can be reprocessed in the RAW Data. Dual frequency depth sounders now allow storing dual points in Auto by Interval when 'Both' Frequencies option is selected.

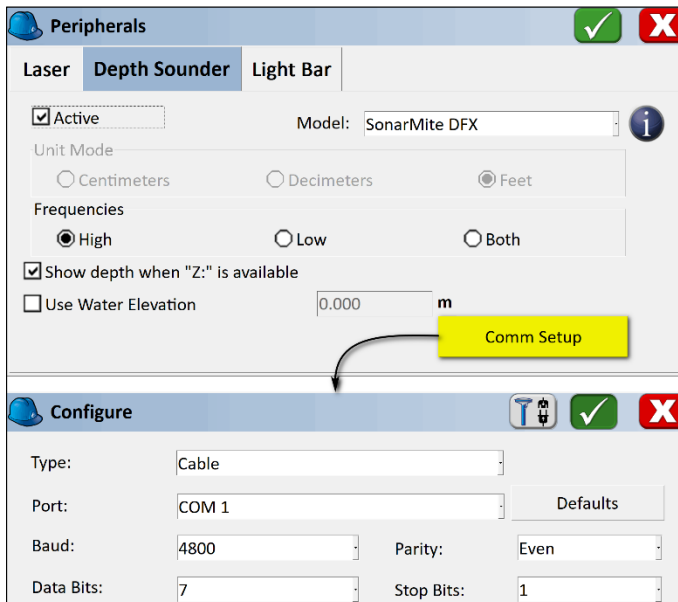

To activate the Depth Sounder, follow these steps:



1. Plug in your Depth Sounder to any of your device's unused COM ports and turn it on.
2. Enter the **Peripherals** menu, and select the DEPTH SOUNDER tab, as shown above.
3. Check **Active**
4. Select the Type of Depth Sounder you are using.
5. If the Unit Mode radios are not grayed, you will have to set the units to correspond to those output by the depth sounder.
6. Specify the Port the Depth Sounder is plugged in to.

### Light Bars

Currently supported light bars are Mikrofyn and Apache. Light bars can be used with either GPS or total stations to provide prominently displayed direction arrows, when staking out a polyline/centerline, or in the Elevation Difference routine, when trying to cut or fill toward a target elevation.

The screenshot shows a software window titled "Peripherals" with three tabs: "Laser", "Depth Sounder", and "Light Bar". The "Light Bar" tab is selected. Inside the window, there is a checked checkbox labeled "Active". Below it, there are three settings: "Light Bar Model" with a dropdown menu showing "Mikrofyn", "Grading Tolerance" with a text input field containing "1", and "COM Port" with a dropdown menu showing "COM2". The window has a green checkmark icon and a red X icon in the top right corner.

To activate the light bar, follow these steps:

1. Plug in the light bar to any of your device's unused COM ports and turn it on.
2. Enter the Peripherals menu, and select the Light Bar tab, as shown above.
3. Check **Active**
4. Select the Type of light bar you are using.
5. Set the **Grading Tolerance** to the maximum permissible deviation from the target path or elevation.
6. Specify the Port the Light Bar is plugged in to.



## Output

Total Stations will output supported NMEA messages. These messages can be logged to a file or to a selected PC port.

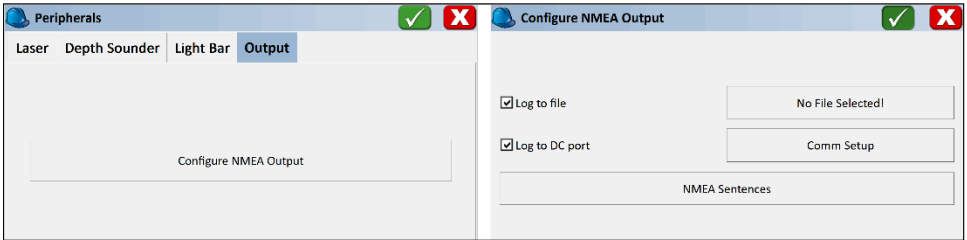



## 5.18 GPS Utilities



Every GPS manufacturer and model has a different set of GPS Utilities. The primary purpose of the Receiver Utilities is reset and/or troubleshoot the GPS receiver.

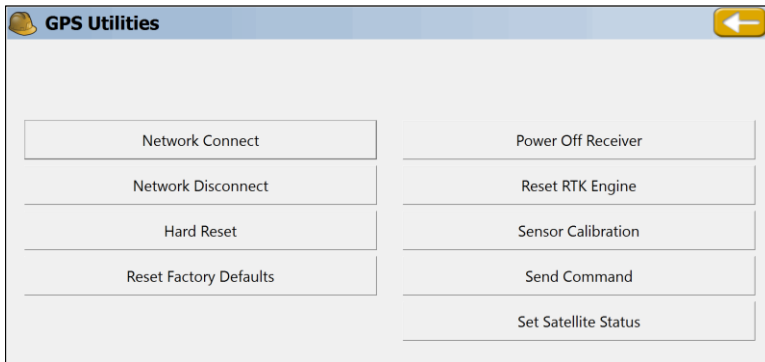

GPS Utilities Parameter	Description
Bluetooth Settings	The Bluetooth settings in SurvPC's Bluetooth Manager (discussed in Comm Setup) do not actually change anything in the receiver itself. In order to make changes to the receiver's internal Bluetooth settings, it is necessary to go into Receiver Utilities and click on Bluetooth Settings.
Check RTK	This tells the user current RTK Status
Configure RTK Device	This allows the user to configure RTK Parameters
Disable Wifi Hotspot	This allows the user to disable the Wifi Hotspot
Eject File Card	This allows the receiver to unmount the SD card from the housing (allowing for removal)
Enable Remote Control	
Enable Wifi Hotspot	This allows the user to enable the Wifi Hotspot
GSM Modem Reset	This will reset the GSM Modem, helpful with a weak signal
Hard Reset	This will initiate a Hard Reset command to the receiver
Known Point initialization	This allows the user to initialize the receiver's position, helpful in PPP configurations



---

Network Connect	This allows the user to connect to the APN, allowing for RTK correction streaming
Network Disconnect	This allows the user to disconnect from the APN, allowing for the network to disengage data streaming
OmniSTAR Status	This allows the user to see status of the tracked OmniSTAR signal
Power On / Off Receiver	This allows the user to power on / power off the receiver
QuickStart	This allows the user to utilize the receiver's quickstart capabilities
Reset Factory Defaults	This allows the user to reset the receiver's configuration to factory defaults
Reset Receiver	This allows the user to reset the receiver, usually does not erase flash memory (check with your specific receiver manufacturer for full details)
Reset RTK Engine	This allows the user to reset the RTK Engine, helpful if a dominant satellite signal becomes occluded
Seed position	This allows the user, in a PPP configuration, to set the position prior to the convergence period.
Send Command	This allows the user to send a command directly to the receiver
Sensor Calibration	Allows for receivers with IMU capabilities to be calibrated
Set Radio Parameters	This allows the user to configure the radio parameters for correction streams
Set Satellite Status	This allows the user to specify satellite constellations and particular satellite signal reception
StarFire Status	This allows the user to see status of the tracked StarFire signal
Theft Protection	This usually will setup a PIN (check with your manufacturer for further details)
Update Clock from GPS	This allows the user to set the clock from GPS signals
Upload Firmware	This allows the user to upload firmware to the receiver

---



## Sensor Calibration – One Point Test

SurvPC offers a ‘One Point Test’ utility in GPS Utilities to help users to get more accustomed to the IMU capabilities of their receiver.

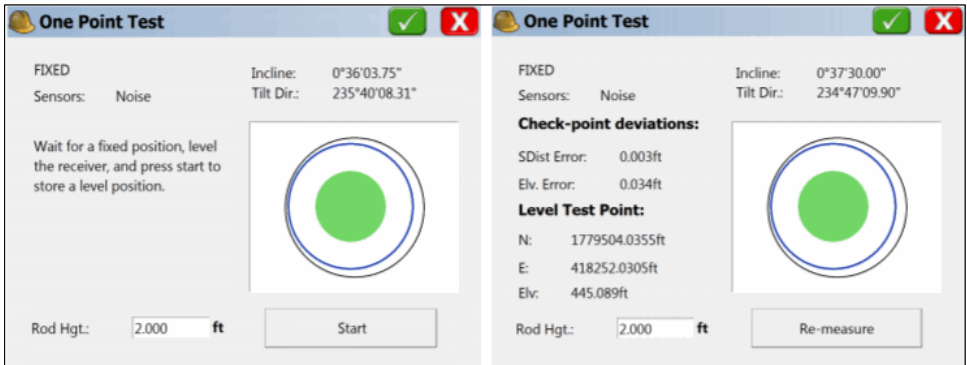

To use the feature, make sure your Rover has a FIXED solution shown in the upper left, then level the receiver and press the Start button to take a level reading. Then hold the tip of the pole in a fixed location, and practice tilting the top of the pole. The software will apply corrections based on the tilt, and the screen will display the error between the fixed location and the calculated location. Errors will be grayed out when the position is not FIXED or too much noise is preset or if measured tilt is >30 degrees. Every receiver is different, and calibration is tied to location and temperature. Using the One Point Test can help field crews understand the limitations of their receiver. Very bad results in this screen could indicate that the receiver needs to be re-calibrated.

## GPS Utility for GPS Simulation

If running GPS simulation, the starting point can be reset using the special GPS utility. Enter the new Lat/Lon for the position.

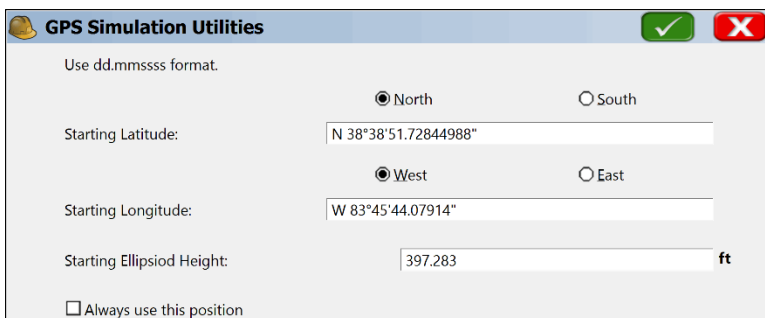



## 6 Survey

This chapter provides information on using the commands from the Survey menu.

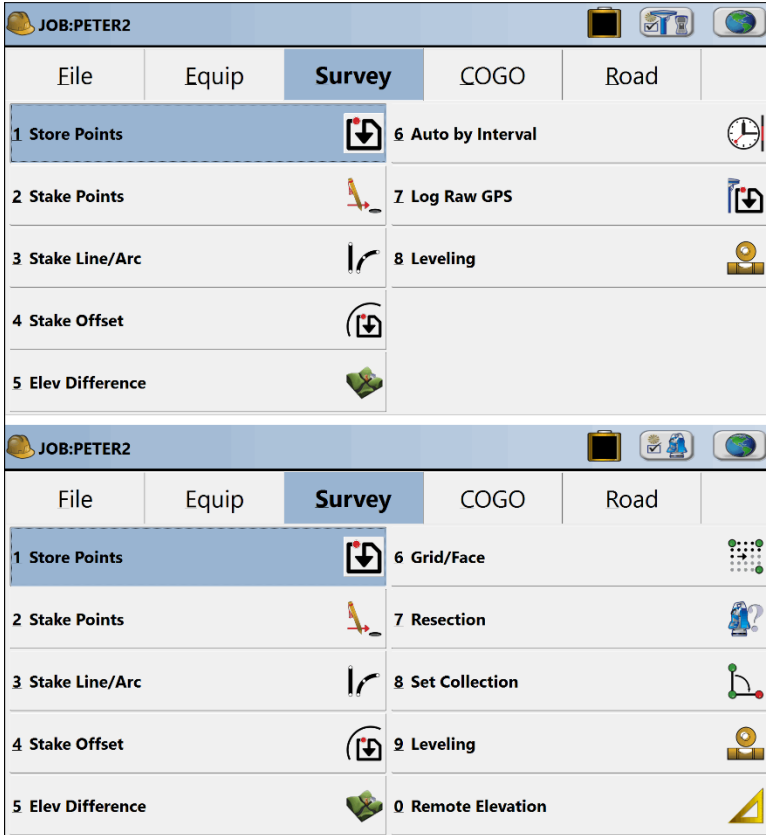





## 6.1 Orientation (Instrument Setup)



The instrument setup dialog is displayed upon entering every active survey routine, unless "Prompt for Total Station Setup" is clicked off within **Configuration**. You also go directly to the Orientation screen whenever you click the tripod icon in all survey and stakeout routines. So, if "Prompt for Total Station Setup" is clicked off, but your occupied point has changed, then within the survey routine, tap the tripod icon (lower right) to update the occupied point and other setup information. The "From Job" button will recall the occupied point, instrument height, backsight point and orientation from a previous job, which is useful when creating a new job while already set up in the field.

Field	Value	Unit
Occupy Point:	1	
Instr. Height:	2	ft
Backsight Point:	4	
Backsight N Azi:	31°36'19"	
Backsight HT:	2	ft

Use Backsight HT for Foresights

Buttons: Confirm NEZ, From Job, Backsight

When simply confirming the backsight information, if the OK button (green checkmark) is active, you can simply press Enter or click OK to move on to the active survey screen. If the OK button is grayed out, that means the program has detected a new occupied point (or the first one of the survey). Then you must click the Backsight screen and take an angle and/or distance measurement to the backsight.

When configured to robotic total stations, the **Tripod** icon takes you first to the robotics control screen for quick adjustments, and then back to more foresights. From there, you can tab to the backsight screen to access all of the backsight functions, then easily return when you are finished to the Foresight Screen.

*If the user enters a rod height or instrument height in this screen, and then presses cancel, SurvPC will prompt the user to save the entered heights.*



- **Occupy Point:** You can manually enter the occupied point ID (occupied/setup point) or click the List icon and select the point from a list of points. You can also choose the point by clicking the **Map** icon and selecting the point from the map itself by tapping a specific point. Finally, a third icon offers the ability to occupy a station and offset on a known horizontal alignment, without knowing a point number.

**Point Projection**

Pt ID: 2

Sta: -17222+71.581

Off: R 599491.001

El: 397.308 ft

Centerline

DEMO

Demo2

Peter1

Peter1Edit

C:\Carlson Projects\Data\

Select CL

Reload CL

CL: DEMO

Beg: 0+00.000

End: 3+08.327

In the Station/Offset method, you must load a horizontal alignment (centerline) file and then specify a station and offset. If you click the "store to disk" icon, it will store the station and offset and after clicking OK in this dialog, you will be prompted for a description, and the next available point will automatically be assigned. If you enter a station and offset that is equivalent to a known point, that point will populate in the Pt ID field. And if you enter a point in the Pt ID field, it will confirm to you the station and offset. In road work, this option can be used simply for confirmation of the correct station and offset for any entered point.

- **Instr. Height:** This is the height of the instrument from the center of measurement (typically middle of the lens) to the tack in the hub, or ground elevation over which the instrument is set. Units for the instrument height will be set according to the options in **Job Settings**. The units for the job are displayed (ft, ift or m). If you brought a feet and inches tape to the field, and you are set in decimal feet units, you can enter the instrument height as 63" (in which case 5.25 will be computed) or as 5.6.3.8 (5 feet 6 and 3/8", in which case 5.5313 will be computed).
- **Backsight Point:** Here you enter your backsight point ID, or pick it from a list or from the map itself, using the icons to the right. You can also click the station and offset icon, as with the occupied point. A backsight point ID is required, even if you choose to enter an azimuth or bearing only.



- **Backsight Bearing or Azimuth:** This displays the bearing or azimuth between the two entered points, when both points have coordinates. If **Angle Type**, in **Job Settings**, is set to **bearing**, then a backsight bearing will appear. If set to **azimuth**, then the backsight azimuth is shown. (Azimuth should always be used with a 400 circle/gons configuration). When both point IDs have coordinates, the backsight is fixed and predetermined and therefore the bearing/azimuth field is disabled since it cannot be altered. However, if the backsight point has no coordinates, then you must enter a backsight bearing or azimuth, which will be used to calculate the null or zero coordinate point ID.
- **Backsight Height:** This is the height in feet or meters (depending on your configuration) of the target, from ground elevation to the center of the lens for example. Even if working in English units, you can enter a 2-meter target height using 2m. This converts to 6.5617 feet automatically after you press Enter.  
*Note: The backsight target height will default to the previous backsight target height on future setups. The foresight target height is kept distinct and will default to previous foresight target heights but will not automatically match the backsight target height. If you prefer to survey by setting the prism pole to a fixed height for both backsights and foresights, be aware that you will have to put in 2 initial target heights: one for the first backsight in the backsight screen and one for the first foresight in the foresight screen, in order to get both "remembered" values established.*
- **Use Backsight Ht for Foresights:** This option will link the backsight height and the foresight height to accommodate the use of a single prism for both the backsight and foresight readings, rather than a fixed tripod at the backsight and pole for the foresight.
- **Confirm NEZ:** This option will display the full coordinates and description of both the setup and backsight points. By default, the Setup coordinates will be displayed. You can tab to the backsight coordinates. Press Enter or tap OK to exit this dialog.
- **From Job:** This will recall an occupied point, instrument height, backsight point and backsight orientation from another job. You should use this option when you are already set up, have previously taken a backsight and other measurements and wish to start a new job with the same backsight orientation and information. This is known as the "Restore Occupation" feature. Select your "source" raw file containing the last backsight used. The occupied point and backsight point will be added to the current job file automatically.
- **Backsight:** Continues to the Take Backsight screen.
- **OK or pressing Enter:** Continues straight to the **Foresight** screen. If **OK** is not highlighted and not ghosted, pressing **OK** will still go to the Foresight screen, even if Enter does not.
- **Settings Icon.** At the top of the screen, the "Settings" icon to the left of the green check will bring up the Configuration Options, and is the same as selecting Equipment, Configure.



## 6.2 Orientation (Backsight)



The backsight dialog has **Setup** and **Results** tabs showing the results of a measurement to the backsight.

**Store Points** (Single Setup) Remote Benchmark

Occupy Point: 1

Instr. Height: 2 ft

Backsight Point: 4

Backsight N Azi: 31°36'19"

Backsight HT: 2 ft

Use Backsight HT for Foresights

Confirm NEZ From Job **Backsight**

**Backsight**

Set to Zero: 0°00'00"

Setup Results

OC Point:	1	BS Point:	4
BS AZI:	31°36'19"	BS Bearing:	N31°36'19"E
Inst Hgt:	2.000ft	BS Hgt:	2.000ft

Set Angle Check Angle Check

Set Angle and Read

- **Set Angle Option List:** There are three options for setting the reference angle in backsight. They are found in the options list at the upper left of the Take BS screen:

**Set to Zero:** This is the most commonly used option. A message is sent to the instrument to set it to zero, then the backsight is taken at a zero reference angle. Angles are then typically turned to the right from zero.

**Set to BS (Backsight) Azimuth:** In this scenario, the backsight direction in the gun is set to the azimuth of the backsight. For example, if the backsight azimuth is 180 degrees, then an angle to the right of 10 degrees would read 190 degrees from



the instrument. This is useful in underground mine surveying because it ensures that the readings displayed by the total station always refer to true azimuth. Some surveyors are “azimuth” surveyors and others prefer “set zero”.

**Set To:** Allows the user to set the value.

**Use Current (Do Not Set Angle):** Uses whatever direction reading is already in the instrument.

- **Set Angle and Read:** This button will set the horizontal angle and read the distance to the backsight. The program defaults to the **Set Angle and Read** option (the large, lower button), on the assumption that in most cases, you will be taking a distance measurement to the backsight.
- **Set Angle:** This button will only set the horizontal angle. If you are just backsighting an object or plumb bob without a measurement, choose **Set Angle**. You can tap **Set Angle** on the screen or, using the keyboard, enter ALT-S.  
*Note: On most buttons, the underlined letter in the name is the hotkey which, in combination with the ALT key, will access the function of the button. On this menu, for instance, ALT-A would go to **Check Angle**.*
- **Check:** This enables the surveyor to determine whether the instrument has drifted off the point. Based on what is presented here, the surveyor may decide to reset the BS angle, or to actually re-level and re-shoot the BS point. More commonly, you would do a **Check Backsight** after taking a large set of foresights. You may want to be sure that you haven’t bumped the instrument or experienced settlement in the tripod legs.
- **Check Angle:** This button will simply read the angle currently in the instrument and compare it to the reference angle. Choose **Check Angle** to re-sight on the backsight and obtain an angular error report (no distance comparisons are made).
- **Turn to BS:** With robotic total stations, you have the option to automatically turn to the backsight. This button will turn the instrument to the previously set backsight angle so that a **Check Angle** or **Set Angle** can be performed. Once you press **OK** to go back to the foresight screen, the instrument will automatically prompt if you want to return to the previous foresight position.

Whether in a conventional or Manual Total Station configuration, pressing **Set Angle and Read** or pressing **Enter** will cause a backsight to be taken. In Manual Total Station configuration, a dialog will appear for you to manually input the angle and distance measurements.

Pressing **Enter** or **OK** completes the backsight setup and leads to the foresight screen, where shots are taken, readings are presented, and points are plotted graphically.



### **Types of Total Station Backsights - Handling Missing Information**

The SurvPC backsight procedure will allow last minute entry of the backsight coordinate values if none are found or will calculate the backsight coordinates using the azimuth and distance of the measurement. If both the Station and Backsight have coordinates (non-zero northings, eastings and elevations), the backsight azimuth is computed, and the coordinate values are not altered.

### **Known Station and Backsight Azimuth to Backsight Point of Unknown Coordinates**

In the case that the coordinates of the station are known and you shoot a backsight point of unknown coordinates, a backsight point will be calculated. Note that when a zero-coordinate backsight point is encountered, the program will prompt the user to "Enter Coordinates or Use Azimuth". This prompt appears only when the **Use Azimuth** option has been selected. If you choose only to **Set Angle**, the backsight point will not be calculated, but is still a viable entry in the raw file. Some raw file processing programs make use of this backsight point with zero coordinates as a backsight azimuth reference. It is recommended that you use distinct new point IDs for all foresight points. Don't re-use a backsight point ID that served as a "dummy" point to initiate the "set zero" backsight, unless you plan to re-use it for the same backsight again.





### 6.3 Orientation (Remote Benchmark)



This is a command for total station applications only, in which the elevation of one or more remote, but known, points are used to compute the elevation of the occupied Station. The **Remote BM** tab is the 2nd to the right in the Backsight screen. The main screen is shown below.

**Store Points** [Print] [Check] [Close]

Single Setup **Remote Benchmark**

Occupy Point: 1 Read

Instr. Height: 2.0000ft Results

Oc. Pt. Elev.: 397.33109ft Store

BM Point:  [List] [Target]

Target Hgt: 0 ft

BM Elev.:  ft Confirm NEZ

- **Read:** You have the option to transfer the elevation from a single benchmark by taking a reading on it, any number of times, in any face. You may also use multiple benchmark points, any number of times, in any face. If you turn on Direct and Reverse for Resection in Configuration, Sets tab, robotic instruments will perform a D&R automatically for remote elevation readings as well.

**Results** [Check] [Back]

Average Station Elevation: 390.0749

On BMark	BM Elevation	Calc dZ	Meas dZ	Stn Elev	Residual	Zenith	Slope Dist.	
Y	2	397.3084	-0.0226	7.2336	390.0749	0.0000	87°00'00"	100.0000

- **Results:** The readings taken on the benchmark are reported in the Results dialog. All of the readings taken will determine an average instrument point elevation.
- **Store:** Click Store to update the instrument point elevation. A store point record will be recorded to the raw data file.



## 6.4 Orientation (Advanced Occupation)



The Advanced Occupation command allows for multiple points to be used to orient the backsight, conducting a least squares analysis on all measurements taken. It is sometimes referred to as the "Multiple Backsight" command. The Advanced Occupation command will also locate the occupied point if sufficient measurements are taken, allowing for the storing or overwriting of the occupied point coordinates. The appearance of this option in the backsight screen is itself dependent on turning on the "Show Advanced Backsight" option within Configuration. This leads to a third "tab" option within the Store Points, Stake Points and other commands involving backsights, called "Occupation", short for "Advanced Occupation".

The screenshot displays two windows from a surveying software application. The top window is titled "Configure" and has three tabs: "General", "View", and "Sets". The "General" tab is active, showing a list of checkboxes: "Use Unique IDs for Linework" (unchecked), "Show Continuous Total Station Angles" (unchecked), "Show Advanced Backsight" (checked), "Always Display Average Statistics" (checked), "Show Slope Info in STK Points" (unchecked), "Visual Alert in STK for GPS not Fixed" (unchecked), and "Force All Features to be Selectable" (unchecked). Below the list are input fields for "No. of Readings to Avg" (set to 1), "TS:" (set to 1), "GPS:" (set to 1), and "Enter/Store Icon - TS:" (set to "Read & Store"). The bottom window is titled "Store Points" and has three tabs: "Single Setup", "Remote BM", and "Occupation". The "Single Setup" tab is active, showing input fields for "Occupy Point:" (1), "Instr. Height:" (2 ft), "Backsight Point:" (4), "Backsight N Azi:" (31°36'19"), and "Backsight HT:" (2 ft). There is a checkbox for "Use Backsight HT for Foresights" which is unchecked. At the bottom are three buttons: "Confirm NEZ", "From Job", and "Backsight".

Although standard backsight procedure may be to take one or more readings to a single backsight, the Advanced Occupation command allows multiple readings to be taken for the backsight, to points identified in advance, leading to a "best fit" backsight orientation computed by least squares methods. Consider the graphic below, showing a





proposed occupied point (tripod) and three known point IDs as originally surveyed and precisely located based on a due North backsight.

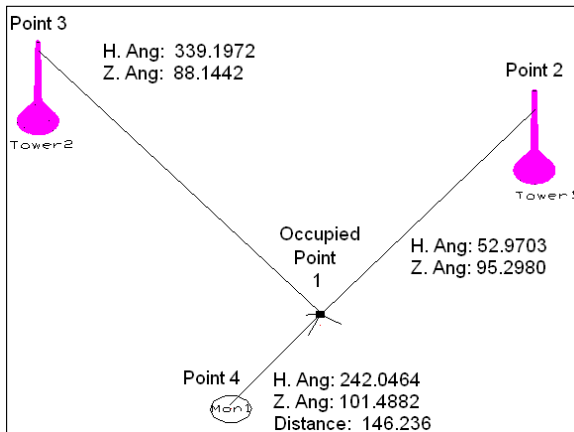

Although it is sufficient to backsight to point 4, from known occupied point 1, taking additional measurements to point 2 and point 3 can lead to an "averaged" backsight and best fit orientation. Furthermore, if point 1 is not known, the position can be determined by the least squares calculations within Advanced Occupation, similar to a resection. Even if point 1 is known, if the calculated position is saved and not overwritten, then a redundant position for point 1 can be stored to the raw file, leading to more precise calculation of point 1 by Network Least Squares methods using office software, such as Carlson SurvNet.

In the above example, points 2 and points 3 can be considered to be towers and sighted for angle only measurements, while the measurement to point 4 would include both angle and distance. Furthermore, the data for these points will be recalled from a control file, so that they can be re-used on multiple jobs. And in this example, the angles will be recorded in gons/grads, or the "400 circle", with distances in metric. In the new file (Ville2.crd), a control file which we will call RadioTower.crd is referenced within Job Settings, Options tab. Note that it is not necessary to extract the backsight points from a control file. However, in developed areas with known control points, it is a useful technique to store control points to a distinct file so they can be easily recalled in all new jobs. The elevations on the radio tower points represent only the vertical positions originally measured and can be ignored when used in Advanced Occupation (or in Resection). The radio tower points will be used only for their north and east coordinates.



**Pts:3 <= 4**

Point ID	Northing(ft)	Easting(ft)	Elevation(ft)	Description	Point ID
2	2734379.45	808827.41	251.083	Radio1	2
3	2734374.23	808350.89	291.067	Radio2	3
4	2734041.32	808526.18	224.493	MON1	4

Edit      Add      Find      Delete

**Job Settings**

New Job   System   Format   **Options**   Stake

Use Control File  
Select File      C:\Carlson Projects\Data\RadioTowers.crd

Time Stamp Each Point  
 Store GPS Accuracy in Raw File  
 Store GPS Vectors in Raw File when available  
 Use Code Table for Descriptions  
 Recall Job Road Files  
 Auto Load Map  
 Auto Save Map  
 Recall World Image

The Advanced Occupation command can even be run from a file containing no coordinates, assuming backsight points can be referenced from a control file. Begin by selecting the command Store Points in the Survey Menu, establish point 1 as the occupied point, 2 as the backsight and enter the correct target heights (0 for the radiotower point 2). Then click to "Occupation". The first screen appears below:

**Store Points**

Single Setup   Remote BM   **Occupation**

Occupy:      1      [Menu]      [Backsight]      [Occupation]

Inst. Height:      1.4      ft      Desc:      OccPt      [Menu]

Use Known E/N       Use Known Elev  
N:      None      Z:      None  
E:      None

Use Backsight HT for Foresights

Configure      Observations



If the occupied point is not known, as in this case, then N, E, Z values appear as None. If the point is known, then the N, E, Z values appear with their coordinates, and you must decide whether to "Use Known E/N" and "Use Known Elev" before proceeding. The next step is to click the Observations button. Note that if a previous list of targets was created, you will be prompted to re-use the target list. In any case, you proceed to the following screen(s):

**Add Target** [Green Checkmark] [Red X]

Pt. No: 3 [Menu] [Red Arrow] [Green Arrow]

Target Height: 2 ft Desc: Radio2 [Menu]

Use Known E/N  Use Known Elev

N: 2734374.23000ft Z: 291.06700ft

E: 808350.89000ft

HA  ZE  SD Target: Leica 360 [Menu]

On/Off	No	Horizontal Angle	Zenith Angle	Slope Dist.	Set	D/R	Target Type
	1	New Reading	New Reading	New Reading	New Value	New Value	Prism

**Add Target** [Green Checkmark] [Red X]

Pt. No: 4 [Menu] [Red Arrow] [Green Arrow]

Target Height: 2 ft Desc: MON1 [Menu]

Use Known E/N  Use Known Elev

N: 2734041.32000ft Z: 224.49300ft

E: 808526.18000ft

HA  ZE  SD Target: Leica 360 [Menu]

On/Off	No	Horizontal Angle	Zenith Angle	Slope Dist.	Set	D/R	Target Type
	1	New Reading	New Reading	New Reading	New Value	New Value	Prism

Entering point 2 as a target leads to presentation of the coordinates for 2. Since this is an "angle-only" measurement, turn off the slope distance "SD" option and turn off the "Use Known Elev" option. The "Zenith Angle" option is also irrelevant but can be left on or off. The goal of Observations is to load in advance all targets that will be used for the multiple backsight measurement. So if in this case, our goal is to backsight control points 2, 3 and 4, we would select those point IDs. Note that if the current job contains no points 2, 3 and 4, then you can simply enter them as targets, and the program will automatically find them in the control file where they don't exist in the current job. However, if the current job contains points 2, 3 and 4, you would need to use the "From List" icon to the immediate right of the Target prompt and then select the "Control" file



option at the top of the List Points dialog as shown below. This ensures the selection of point 2 from the control file.

Point ID	Northing(ft)	Easting(ft)	Elevation(ft)	Description	Point ID
2	2734379.45	808827.41	251.083	Radio1	2
3	2734374.23	808350.89	291.067	Radio2	3
4	2734041.32	808526.18	224.493	MON1	4

Edit Add Find Delete

The process of loading, in advance, all targets to be used is then repeated for points 3 and 4. Additional points are added by tapping the "Add" button shown below:

On/Off	Target	HA	H Res(s)	Norm	ZE	V Res(ft)	Norm	SD	D Res(ft)	Norm	N/E	Z	HT	Desc	Ta
	3	0/(0)			0/(0)			0/(0)			<input checked="" type="checkbox"/>	<input checked="" type="checkbox"/>	2.0000	Radio2	3

Add New Target or Press Measure.

Add Edit Up Down Solve Measure

In this example, we would add points 3 and 4. Note that for point 4, a target height of 2 meters will be used, and the slope distance reading and elevation of point 4 will also be used in the calculation.

On/Off	No	Horizontal Angle	Zenith Angle	Slope Dist.	Set	D/R	Target Type
	1	New Reading	New Reading	New Reading	New Value	New Value	Prism



**Add Target** ✓ ✕

Pt. No:  ☰ 🗑️ ↻

Target Height:  **ft** Desc:  ☰

Use Known E/N  Use Known Elev

N: 2734041.32000ft Z: 224.49300ft

E: 808526.18000ft

HA  ZE  SD Target:

On/Off	No	Horizontal Angle	Zenith Angle	Slope Dist.	Set	D/R	Target Type
<input checked="" type="checkbox"/>	1	New Reading	New Reading	New Reading	New Value	New Value	Prism

When distance measurements are involved, the prism offset can be entered distinctly for each measurement.

Set	D/R	Target Type	Prism Offset	No
New Value	New Value	Prism	0.00mm	1

When the entire list of targets has been entered, you then select the target to measure first (e.g. point ID 2) and then tap "Measure".

**At: 2** ☰ ✓ ← ✕

On/Off	Target	HA	H Res(s)	Norm	ZE	V Res(ft)	Norm	SD	D Res(ft)	Norm	N/E	Z	HT	Desc	Ta
<input checked="" type="checkbox"/>	2	0/(0)			0/(0)			0/(0)			<input checked="" type="checkbox"/>	<input checked="" type="checkbox"/>	2.0000	Radio1	2
<input checked="" type="checkbox"/>	3	0/(0)			0/(0)			0/(0)			<input checked="" type="checkbox"/>	<input checked="" type="checkbox"/>	2.0000	Radio2	3
<input checked="" type="checkbox"/>	4	0/(0)			0/(0)			0/(0)			<input checked="" type="checkbox"/>	<input checked="" type="checkbox"/>	2.0000	MON1	4

Add New Target or Press Measure.

You will be prompted to turn to the target in direct face and take the reading. Assuming you set zero on the instrument to the backsight to point 2, the following measurements may be entered:



Manual Read <span style="float: right;">✓ ✕</span>	
> Angle Right:	0°00'00"
> Zenith Angle:	95°29'30"
Slope Distance:	0 ft
<b>Complete</b>	
Measurement complete. Do you want to complete a set to the rest of your points?	
<input type="button" value="Yes"/>	<input type="button" value="No"/>

After the first measurement is taken, you are asked if you wish to complete the set to the rest of the points. Click Yes. Then you can take readings to the remaining points, as shown below:

Manual Read <span style="float: right;">✓ ✕</span>	
> Angle Right:	286°22'30"
> Zenith Angle:	88°13'54"
Slope Distance:	120 ft
<b>Manual Read <span style="float: right;">✓ ✕</span></b>	
> Angle Right:	189°07'57"
> Zenith Angle:	101°48'49"
Slope Distance:	146.235 ft

**Figure 3: Measurement to Pt 3 (Upper Image) and Pt 4 (Lower Image)**

When all direct measurements are taken, you will be asked to continue the measurements in reverse face. If you do not wish to do both direct and reverse, you answer N and then continue. The program will announce, "Set Complete". You will return to the list of targets and can then click the green check mark to continue:

Here, you will either be led to the results screen showing the successful calculation, or it will report, "Unable to retrieve solution results". In the case above, the computed results are shown below by clicking Solve:



**Complete**

Complete set to reverse face?

**Complete**

Set Complete

Set to:

Occupation | Adjusted | Measured

Height(ft)	Orientation	95% confidence
1.4	-43°54'08"	11346.7186

Backsight 3 Stations: 2,3,4  
Station: 1 Known.

N(ft)	E(ft)	Z(ft)

Set to:

Occupation | Adjusted | Measured

5000	5000	10	Published
2734350.732	808826.558	285.9	Solved
SemiMajor	SemiMinor	StdDev	
732.3115	737.2141	0.512	95% Confi

9 Observations 4 unknowns.

Note that an added feature of the Advanced Occupation routine is the calculation of the occupied point coordinates. In this example, the original point coordinates for point 1 are: N 2734186.7757, E 808615.8663, Z 228.511. The degrees of freedom is the difference between the number of observations and the number of unknowns. The degrees of freedom increase if more redundant measurements are taken, such as reverse readings or multiple distance readings, and 20+ degrees of freedom would indicate strong statistical confidence. When the OK (green check) button is clicked, you have the option to save the occupied point, in which case you can overwrite the current occupied point, save to a new point ID, or save to the raw file only. Then you continue into the Store Points command or other commands and can take new measurements.

If you have taken both direct and reverse readings, the report includes data on the collimation of the instrument, provided that the collimation option is turned on within the settings option within Advanced Occupation. The Settings option includes the following settings:

**At: 2**

On/Off	Target	HA	H Res(s)	Norm	ZE	V Res(ft)	Norm	SD	D Res(ft)	Norm	N/E	Z	HT	Desc	Ta
	2	1/(1)			1/(1)			1/(1)			<input checked="" type="checkbox"/>	<input checked="" type="checkbox"/>	2.0000	Radio1	2
	3	1/(1)			1/(1)			1/(1)			<input checked="" type="checkbox"/>	<input checked="" type="checkbox"/>	2.0000	Radio2	3
	4	1/(1)			1/(1)			1/(1)			<input checked="" type="checkbox"/>	<input checked="" type="checkbox"/>	2.0000	MON1	4

Add New Target or Press Measure.



**Settings**

**Solution**

Instrumental Errors:

- Collimation
- Zero Index

Physical Constant:

- Refraction Coefficient

**Sets Order**

- BD-BD/BR-BR
- BD-BR/BD-BR

**Measurement Accuracy**

Horizontal Circle: 1 s

Vertical Circle: 1 s

Distance: 1 mm

- **Instrumental Errors: Collimation:** Leads to a report on the collimation of the total station instrument provided that both direct and reverse measurements are taken to the same foresights.
- **Instrumental Errors: Zero Index:** This, when enabled, will allow the Zero Index errors computed and displayed in the Solution report.
- **Physical Constant: Refraction Coefficient:** This option should be selected only if the instrument itself does not automatically apply refraction correction in the reported readings.
- **Sets Order:** The two choices are to take ALL backsight direct readings first followed by all backsight reverse readings (BD-BD/BR-BR) or to be prompted for the reverse reading following each backsight direct measurement (BD-BR/BD-BR).
- **Measurement Accuracy: Horizontal Circle:** Estimation of accuracy is used in least squares calculation.
- **Measurement Accuracy: Vertical Circle:** Estimation of accuracy is used in least squares calculation.
- **Measurement Accuracy: Distance:** Estimation of accuracy is used in least squares calculation.





Prism Offsets can be changed for each total station measurement taken that includes a distance reading. When set to an actual field instrument, the Target dropdown appears.

**Add Target**

Pt. No: 2

Target Height: 2 ft Desc: Radio1

Use Known E/N  Use Known Elev

N: 2734379.45000ft Z: 251.08300ft

E: 808827.41000ft

HA  ZE  SD Target: Reflectorless

On/Off	No	Horizontal Angle	Zenith Angle	Slope Dist.	Set	D/R	Target Type
	1	New Reading	New Reading	New Reading	New Value	New Value	Prism

**Add Target**

Pt. No: 2

Target Height: 2 ft Desc: Radio1

Use Known E/N  Use Known Elev

N: 2734379.45000ft Z: 251.08300ft

E: 808827.41000ft

HA  ZE  SD Target: Reflectorless

Reflectorless  
Leica 360  
Leica Mini 360  
Leica 0mm  
Leica Circle  
Leica Mini  
RefTape  
-30mm  
-40mm

On/Off	No	Horizontal Angle	Zenith Angle	Slope Dist.	Set	D/R	Target Type
	1	New Reading	New Reading	New Reading	New Value	New Value	Prism

If measuring angle-only readings to objects such as radio towers and church steeples, you can stay in prism mode but just click off the SD (slope distance) component.



Click Target Settings and you can set the prism offset from a list of options. Target types are shown in the dropdown.

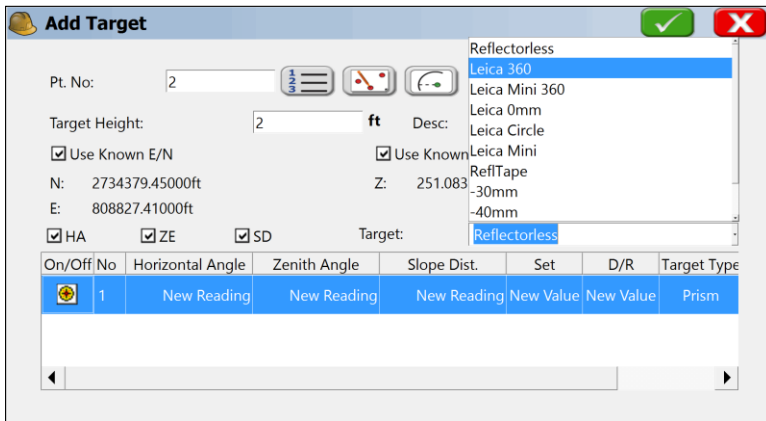

After cycling through all targets and being prompted for reverse readings (optional), you are returned to the target list. If you highlight a target and click Measure again, you are in effect launching another set of readings.

After completing a set, if you click Measure for measurements, you can accumulate multiple readings which can vary from target to target, depending on whether you choose to skip certain target readings, do direct only, etc. Each direct and reverse measurement counts as a reading. You can turn all readings to a target on or off and by clicking Edit, you can turn any individual reading to a target on or off, as shown below:

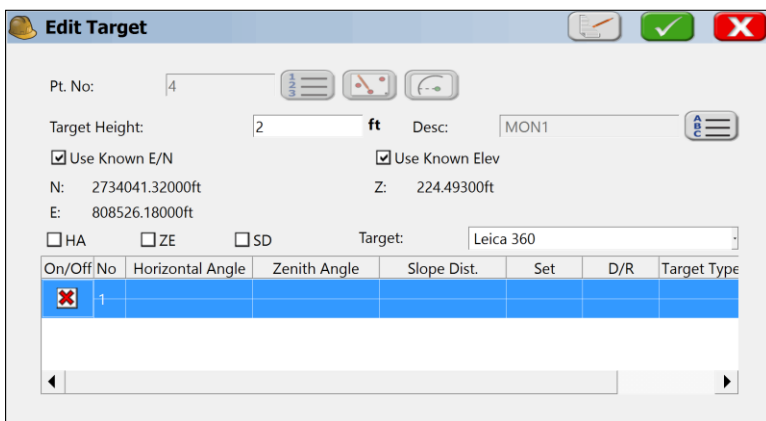



When the process is complete and you exit Advanced Occupation, the program adjusts the backsight orientation with the following prompt, after which it announces "Operation Complete. Angle Set."

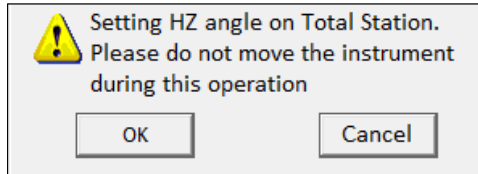

For any reading, within the Edit option, you can delete aspects of the reading. If you want to delete the entire entry in the list of targets (for example, you want to delete target 4 from the list), then select 4 and click Edit, which brings you to the screen in the lower left, then click the eraser icon at the top of the screen and click on "All" (lower right).

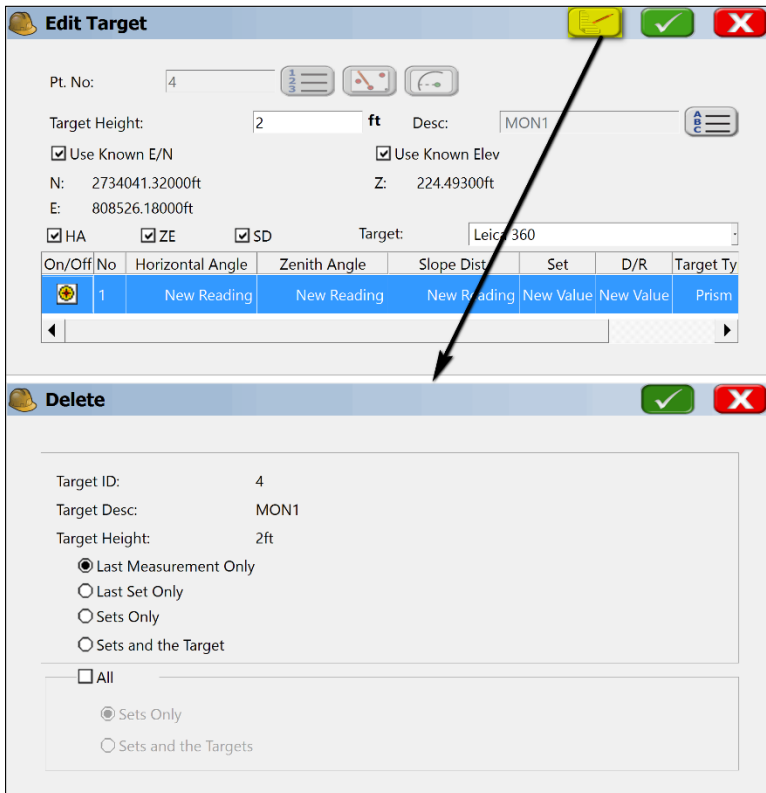



For robotic total stations, the instrument will turn automatically to the direct and reverse positions for the selected targets, provided that within Configure, Sets tab, the "Auto Turn/Auto Read" and "Robotic Set" options are selected as shown below:

The screenshot shows the 'Configure' dialog box with the 'Sets' tab selected. The 'Auto Turn' and 'Auto Read' options are checked. The 'Set Order' is 'BD-FD/FR-BR' and 'No. of Sets' is '1'.

Option	Checked
Stakeout (Read D&R)	<input type="checkbox"/>
Reverse Face - Angles Only	<input type="checkbox"/>
Auto Turn	<input checked="" type="checkbox"/>
Auto Read	<input checked="" type="checkbox"/>
Calculate Reciprocals	<input type="checkbox"/>

Set Collection Routine Options

Option	Checked
Review Readings	<input type="checkbox"/>
Review Sets	<input checked="" type="checkbox"/>
Store Raw Data for Duplicate Points	<input type="checkbox"/>

Set Order:  No. of Sets:



## 6.5 Orientation (Robotics)



The term “Robotics” applies to Geodimeter, Trimble 5600, Leica, Sokkia and Topcon robotic instruments. The Robotics tab has some variations per equipment type.

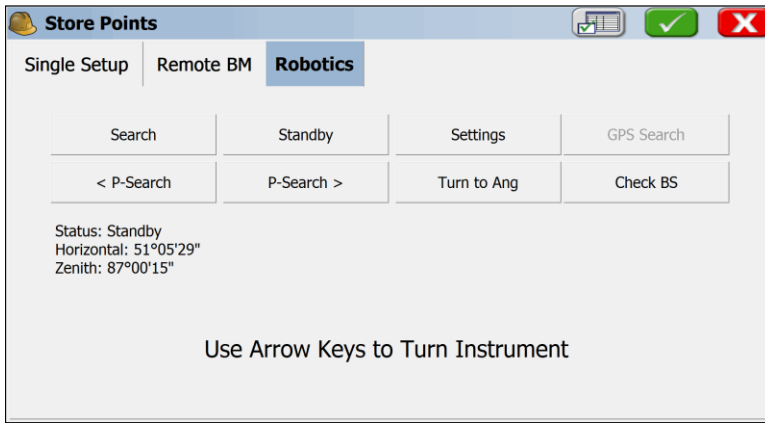

### Arrow Keys for Joystick

ALT-J will take you directly to the robotics dialog from elsewhere in the program. The arrow-key motion is sometimes referred to as the Joystick Speed.

**Leica:** Tapping once in the direction you want (e.g. up) causes the instrument to move slowly, two taps medium, and 3 taps fast speed. Tapping the other direction (e.g. down) stops the movement.

**Geodimeter/Trimble:** Press the arrow key once. After a small delay, the instrument will move an incremental amount. Do not rush too many presses as they all will be completed.

**Topcon:** Holding down the arrow keys allows you to move the base instrument up and down, left and right. When you release the key, the motion stops.

- **Search:** This button will initiate a search to look for the prism or reflector. For Leica, Search initiates an ATR search. Pressing the **Search** or **Quick-Lock** buttons will lock the instrument to the prism and put the instrument back into tracking mode.
- **PowerSearch:** For Leica, the **PowerSearch** option will conduct a fast search, typically less than 10 seconds. **PowerSearch** will find the prism regardless of the original direction the instrument is pointing.



- **QuickLock:** Topcon has an additional search option called Quick-Lock which appears when configured for Topcon 800/8000 Remote using RC2. A **Quick-Lock** search will find the prism in less than 15 seconds.
- **Standby:** This button takes the instrument out of tracking mode. This is useful, for example, in allowing the user to set the prism pole down to drive a stake.
- **Turn to Angle:** This button opens an additional dialog that prompts you for the angle to turn (which can be entered, picked from the Map, or point-based). See the figure below. You can turn to a known point number or to an entered horizontal and zenith angle using **Turn Angle**. When enabled, the **Search After Turn** option, searches and locks on a prism after turning the angle (potentially changing slightly the computed angle). Change Face reverses the face. The lower three buttons (**Turn Left 90**, **Turn 180** and **Turn Right 90**) are common angle turns and minimize user entry when needed.

- **Settings:** This button leads to a series of settings screens that allow you to dial in the speed of motion, range of motion, and other factors governing arrow-key driven movement and automatic searching.
- **Check BS (Backsight):** This button will engage the instrument to automatically check the backsight and lead the user to the Backsight screen with Setup and Results tabs. The Setup tab reflects the setup used and the Results tab reflect the most recent backsight check.

	Setup	Results			
			Angle:	Dist:	Elv(Z)(m):
Calculated:			338°23'36"	7.796	10.000
Measured:			338°23'37"	7.796	10.000
Delta:			0 00'09"	0.000	0.000



## 6.6 Store Points (TS)



This command is designed for total stations and manual entry. It is the principal data collection routine with total stations. **Store Points** interacts with numerous settings, including the feature codes that will draw line work. All settings in **Configure Reading** will impact **Store Points**, including the Number of Distance Readings, Average Direct & Reverse, Hgt/Desc Prompt on Save, Angle Only in Reverse Face and Function of Enter Key. See File, Feature Code List, for discussion of drawing linework, symbols, Line Details and Point Details (option to re-measure existing points).

### Foresights

The **Foresight** screen is entered automatically after exiting the **Backsight** screen. In the backsight screen, if the green checkmark ("OK") is active, you can go directly to the Foresight screen by pressing Enter or clicking the icon itself. And if you turn off "Prompt for Total Station Setup" within **Configure**, you go directly to the foresight screen if there is already a valid backsight. There are two major types of Foresight Screens: (1) Standard Total Station, (2) Robotic Total Station. See the Store Points (GPS) section of this manual for more information on GPS. Only total station setups will be discussed here.

**Store Points**

Single Setup Remote BM Occupation

Occupancy Point: 1

Instr. Height: 1.4 ft

Backsight Point: 4

Backsight N Azi: 0°00'00"

Backsight HT: 2 ft

Use Backsight HT for Foresights

Confirm NEZ From Job Backsight

**Backsight**

Set to Zero 0°00'00"

Setup	Results		
OC Point:	2	BS Point:	4
BS AZI:	221°41'49"	BS Bearing:	S41°41'49"W
Inst Hgt:	1.400ft	BS Hgt:	2.000ft

Set Angle Check Angle Check

Set Angle and Read



## Restore Occupation (from Previous Job)

The backsight can also be used from a previous job, simply click on 'From Job' to set the backsight. A Restore Occupation screen will be presented to the user to ensure the correct job is selected.

The image shows two screenshots from the 'Store Points' software interface. The top screenshot is the 'Single Setup' screen, which has tabs for 'Remote BM' and 'Occupation'. The 'Occupation' tab is active, showing fields for 'Occupy Point' (1), 'Instr. Height' (1.4 ft), 'Backsight Point' (4), 'Backsight N Azi' (0°00'00"), and 'Backsight HT' (2 ft). There is a checkbox for 'Use Backsight HT for Foresights' which is unchecked. At the bottom of this screen are three buttons: 'Confirm NEZ', 'From Job' (highlighted in yellow), and 'Backsight'. An arrow points from the 'From Job' button to the second screenshot. The second screenshot is the 'Restore Occupation' screen, which contains a warning message: 'Please ensure that the instrument position, circle orientation, and instrument height have not changed since the previous setup.' Below this are fields for 'Source' (C:\Carlson Projects\Data\RadioTowers.rw5) and 'Destination' (C:\Carlson Projects\Data\Demo2.rw5), with a 'Change Source' button. At the bottom, there is a 'Source Orientation' field containing the text 'No setup information found in source file.'





## Standard Total Station Foresight Screen

Store Points (standard sideshots and traverses) can be run in either full graphics mode or full text mode. The Text screen is accessed by tapping the helmet in the upper left and selecting Text. To go back to graphics, click the helmet and select Graph. Graphic backgrounds can include linework that you create yourself using commands such as PL and 2DP and O2 (offset) in the Map view. Graphics can also include drawings that you import from DXF using the command IDXf (“in” DXF) found in the Map view of SurvPC. When you exit SurvPC, this linework can be configured to “save on exit” and stay associated with your point file. Note that linework drawn by feature codes or IDXf is on layers which can be “frozen” (hidden) or “thawed” (shown) by the Layer command under **View** in the **Map** screen.

**STORE PTS**

Pt: **11** OP Pt: 2 BS Pt: 4  
HI: 1.4000ft HT: 2.0000ft  
4.7 ft BS Azi: 221°41'49"

AR:12°00'00" N:2734320.2443ft  
ZA:90°00'00" E:808746.8204ft  
SD:100.0000ft Z:247.7830ft

Desc:

CONFIGURE	TRAVERSE	READ
BS/SET	OFFSET	STORE

**STORE PTS**

Pt: **11**  
4.7 ft  
> Category: ALL  
Desc: **EP**

CONC	CREEK	DECK	DEFAULT	DH
DITCH	DL	DMH	DR	DRV
EBOX	EDSTONE	EDWATER	EOG	<b>EP</b>



Enter saves the measurement immediately. If you do a Read, you can review the data within the Text view. If you re-enter the rod height, it re-calculates the Z elevation of the measured point. As you enter the description, a pulldown appears of your Feature Code List or previously entered descriptions. As each letter is entered, such as "e" for edge of pavement, every description beginning with "e" or "E" appears, enabling quick selections. Some users prefer the text screen to take readings because of the larger buttons and text size. The program remains in the Text mode until Graphic mode is chosen again. Graphics mode is selected either by tapping the Helmet and selecting "Graph" or by clicking the graphic icon (1+EP) at the top of the Text screen. Graphic mode is default.

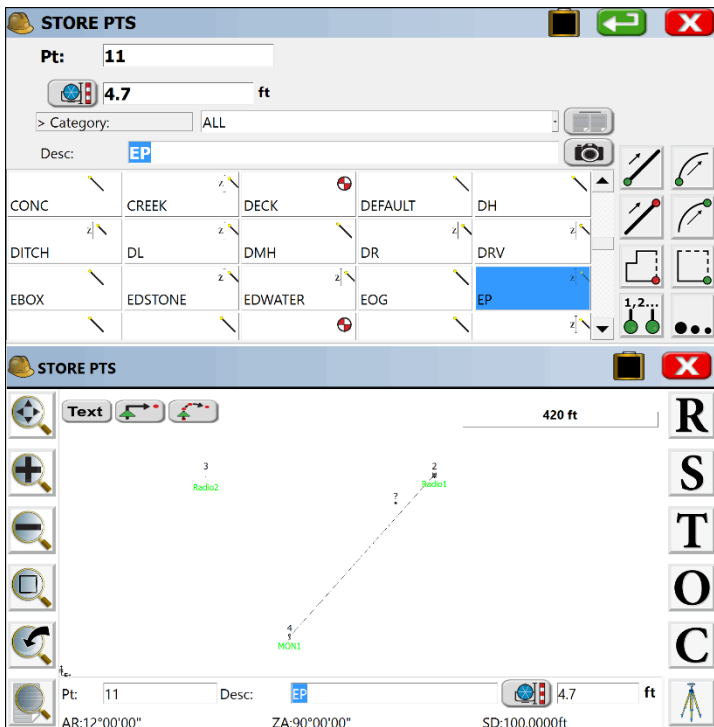

Unless the rod **hgt/description** prompt is enabled, the **Store Points** screen is designed to “quick-store” points, where the user is expected to enter, ahead of time, the correct description and rod heights in the edit boxes shown at the bottom of the dialog.

*Note: SurvPC is designed to produce a 1 keystroke point store, by pressing Enter. If you experience more prompts storing a point, it is because you have certain settings active that cause additional prompts. These settings include 2 options within Configure (Prompt for Height and Description, Prompt for Point Notes), Store FCL Only within Feature Codes, Special Codes, Settings (will prompt if description does not match a feature code), the use of GIS attributes as set in Feature Codes, or the use of "Read or Store" rather than "Read and Store" within Configure. "Read or Store" will turn the first Enter into Read (to review the shot) and the second Enter into Store. Set to "Read and Store" with no Prompt for Height/Description, points are typically stored as fast as you press Enter.*



- **One-Button Measurement with Field Code:** To reduce keystrokes to a logical minimum, there is a way to store points and select distinct descriptions with a single tap of the screen. This is the 1-button feature that can be found within Configuration, View Tab, when selected from the Store Points, Stake Points or other active survey screens. (It is not found in View when selecting Equip-Configuration). To use this feature, select "One Touch (Topo)" as shown below, but also, within the General tab of Configure, turn on both of the following options: "Use Groups of Codes/Desc" and "Show Codes/Desc as Buttons".

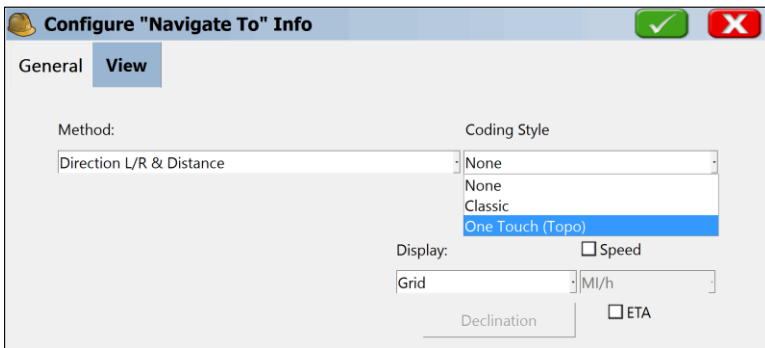
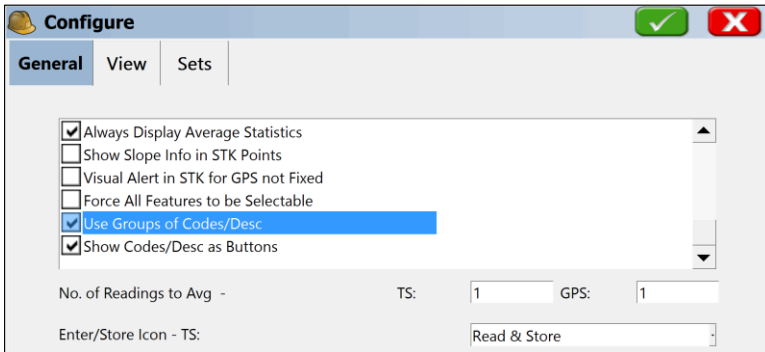

Then when taking a measurement, a screen of icons appears for each description code in the Feature Code List, and by clicking on the icon, you can both take the measurement and select the description, limiting the number of taps to one. With Height/Description Prompt turned off, taps can be limited to the single selection of the desired feature code icon. Only if you need to end line or start or curve would a second tap be necessary. Start by selecting the description list using the "List with Lightning Bolt" icon highlighted below. Then select the desired code, or enter a new code creating a new icon for future use. One tap takes the measurement and applies the correct code. If there are more than 8 codes, a scroll bar will appear to access all of the codes. Clicking the graphic icon in the upper right (1+EP) returns to the normal graphic screen used to take measurements.

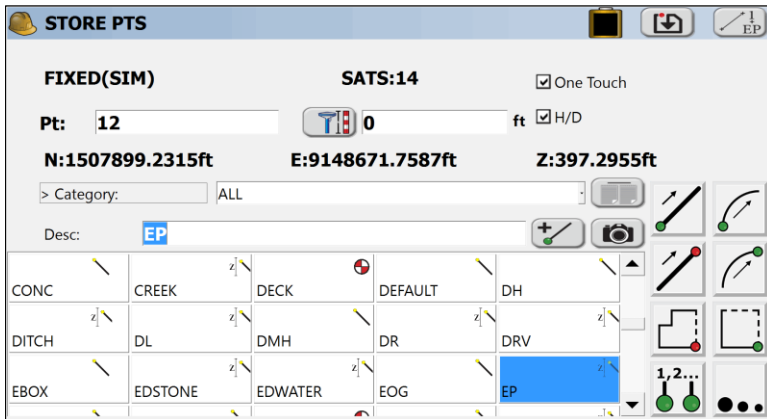
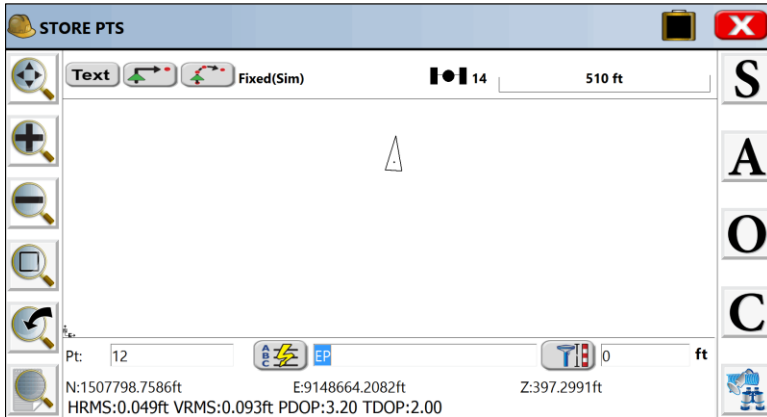

- **Sokkia-Style:** The SDR33 and earlier SDR data collectors have a convenient concept for “Store Last, Read Next”. In this method, you get your descriptions set up and take a shot. The reading is displayed at the bottom line of the screen. You examine it, satisfy yourself it is correct, move to the next point, and take another shot. This was done on the SDR collectors with the Read key, but with SurvPC, can be accomplished with Enter.
- **Normal Foresight Style:** The most typical method is the "Read and Store" procedure as set in Configure. This takes a one keystroke measurement. But you must remember to enter the height and description ahead of time, before pressing Enter. If you want an "after-shot" chance to change the height and description, turn on "Prompt for Height/Description Prompt" within Configure. The Enter key can also be used for Read First, Store Later. This is the “Read or Store” version. Your first Enter is a read, only (like pressing R or entering ALT-R). Your second





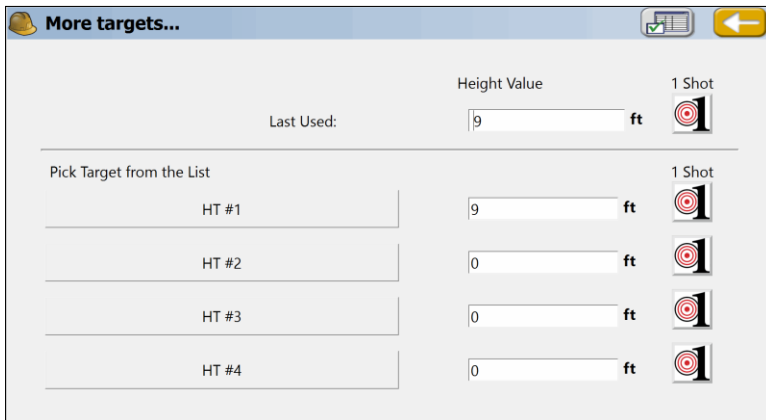

Enter is a store, which can be followed by the Hgt/Desc Prompt on save. This is the most cautious designation of the use of the Enter key for taking shots. Note below that after the read, the point is displayed with a question mark, and the raw data is displayed. It is saved only when Enter is pressed again (or S is pressed, or even Alt S—all of which store a previous Read). In the final Store Point dialog (with Rod Hgt/Desc prompt turned on), you will find the Point Description field. Along with the designated Feature Code list, all descriptions entered for the current job will accumulate in the available Point Description List, allowing the user to select the text graphically, arrow key to the desired text, or highlight and select the correct text after entering the first character in the edit box. An entry of "P" goes right to all text starting with the letter "P". Then you can select the one you want. The Enter key will continue on at this point.

### Rod Height Icon

In both graphics shown above (normal graphic screen and "One-Touch" screen), a "prism" icon  appears with special functions. First, the icon displays the type of prism used. In this case, a "classic circular glass prism" is selected. Each prism has its own distinct icon. Secondly, this icon, if tapped, allows a single 1-shot measurement at a distinct rod height and will return to the current rod height after the single shot. When tapped, the following screen appears:



More targets...		Height Value	1 Shot
Last Used:		9 ft	
Pick Target from the List			
HT #1		9 ft	
HT #2		0 ft	
HT #3		0 ft	
HT #4		0 ft	

If the pole was raised to 8.1 feet for a single measurement, you would enter 8.1 in the "Last Used" line and then click the 1-shot icon to the right. Then after the measurement is made, you would return to 6.5617 (2 meters), the "Last Used" rod height. If you have distinct positions on the prism pole that you may wish to recall, you can click the "Settings" icon at the top of the screen and enter them. For example, if the Maximum rod height was 9 feet, you can enter that height and even describe the target position as "Max Hgt". Then you can switch to this height for a series of shots by selecting it using the prism icon, or you can select it once using the 1-Shot icon and return to the "Last Used" height. Within Settings, there is even an option to "Use



Hotlist to Pick Targets", so when you click the prism icon, you actually see the Hotlist of heights and can select them quickly using the icon as shown below. This Hotlist offers quicker access to multiple, frequently used rod heights. Turn off "Use Hotlist to Pick Targets" to restore the screen option shown above, which has the convenient "1 Shot" option.

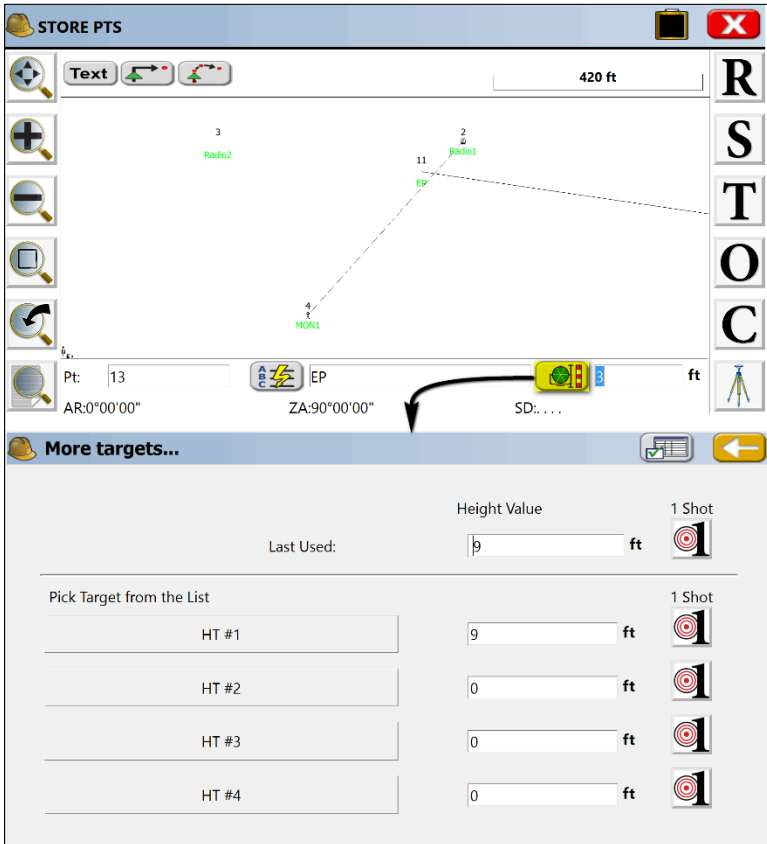



## Height/Description Prompt

When this option is turned on within **Configure (EQUIP menu)**, you obtain the full list of Feature Codes plus any descriptions you have entered that are not included in the Feature Code list. Shown below is a reflectorless shot (rod height=0) with Height/Description Prompt on.

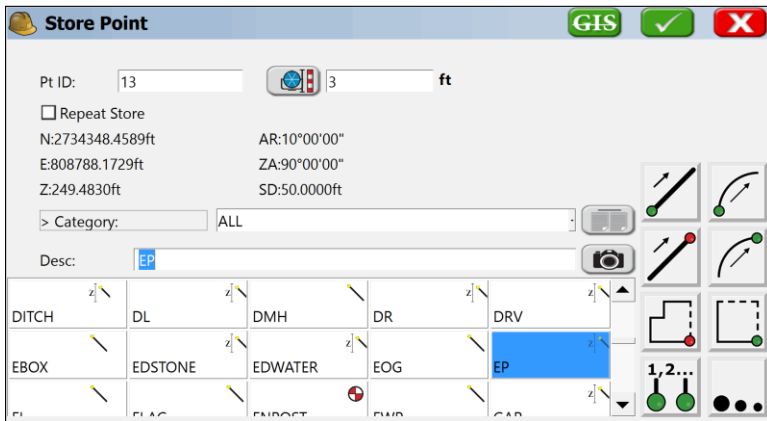

Symbols are shown as circles, and polyline features as lines. Polylines that are 3D include the "Z". As a short-cut to entering the special codes to start and stop lines, you can use the icons that appear at right. Of the 8 icons shown, going left to right starting at the top, they represent start polyline, start curve, end polyline, end curve, close polyline, close rectangle, designate specific "unfinished" active line, and "more options", leading to icons for Offset Horizontal and Offset Vertical.

## Robotic Features

The status of the robot is displayed in the upper left-center, next to TEXT and above the Map. Status modes include:

- **Tracking:** Locked onto the prism and following it (shows the "man with pole" icon). If not tracking, there is a line through the icon.
- **Locked:** Shows the "Lock" symbol, meaning the instrument is following the prism. You can be locked and following the prism but not tracking (taking distance measurements, showing position of prism on the screen).
- **Standby:** Stopped in the last position it was in and ready to resume Tracking.
- **Searching:** Looking for the prism (shows an hourglass).
- **No Data:** Brief mode between losing the prism and beginning an automatic search.

The **search/standby** and **lock** icons let you initiate a Search after a lost lock condition or go to Standby if currently locked (to drive a hub and stop the gun from moving), or go back to Lock, from Standby (after driving the hub). In reflectorless mode, you would see a line through the prism. You are locked and "tracking" real-time, meaning distance measurements are being taken.



## Continuous Reflectorless Measurement for TS

For instruments that support it, it is now possible to press the tracking icon in reflectorless mode to begin continuous reflectorless measurement.

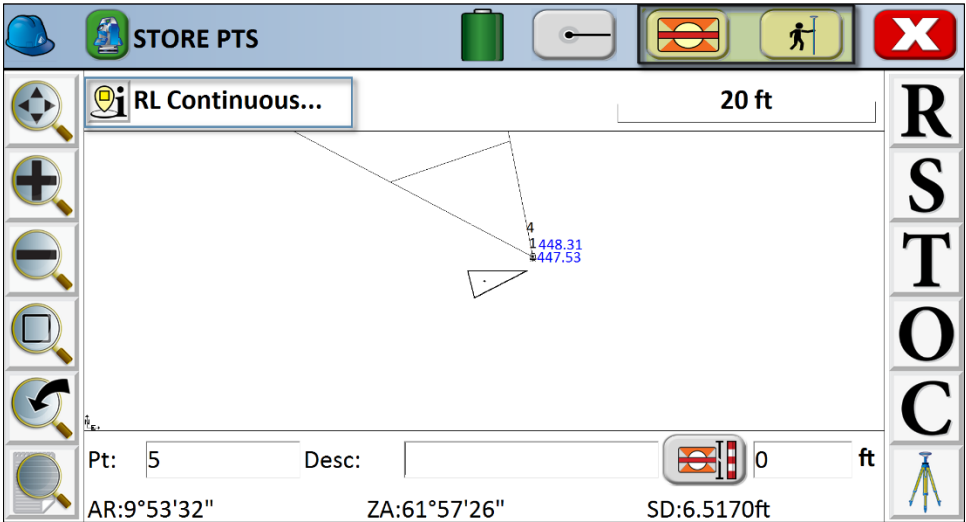

The tracking icon, takes the EDM signal on and off. With the signal on, more power is used, but you gain a lot by seeing continuous, real-time distance readings and by seeing your position on the screen, in the form of a triangle. Shots are nearly instantaneous but respond to the “fast-tracking” mode of the EDM (typically 10mm). If taken out of EDM Tracking, you lose your real-time movement on the screen, but measurements will respond to the accuracy of your Equipment Settings, which may call for standard or fine mode.

When a measurement is made and the instrument is locked on the target, tracking can occur (distance measurements), which then shows the target moving on the screen as a triangle. This uses battery, so "After Reading - RTS" is a setting, which you can choose Standby, Lock, Track, or Previous State, found within C for Configuration (when using robotic total station drivers).



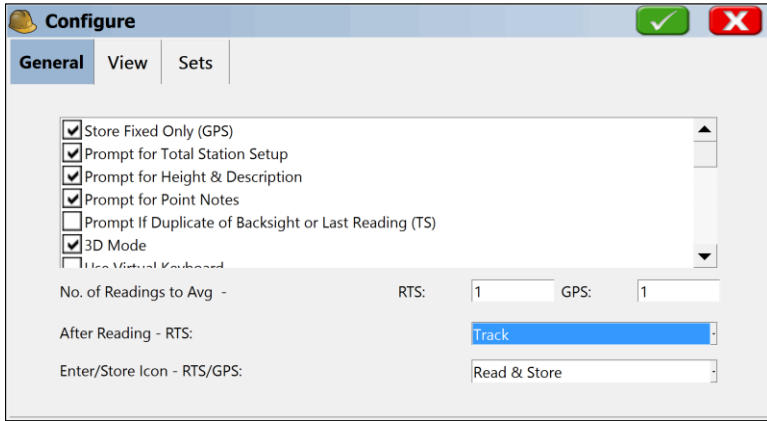

Leica robotic total station users in particular, when doing topography or as-built surveys, prefer to set "After Reading – RTS: Track", in order to save battery between measurements. Instead, they simply keep the instrument set “After Reading – RTS: Lock” or following the prism, but not tracking (taking distances).

*Note: The response to losing lock when taking foresights with robotic total stations is for the instrument to stop where it is. If you have enabled Search when Lost Lock in instrument settings, the instrument will start searching immediately on loss of lock. Alternately, when running remotely, you can use the joystick-arrow controls to move the instrument towards you and obtain lock again.*



## 6.7 Store Points (TS Offsets)



Making offset points using a total station requires tapping the O/Offset button (or entering ALT-O) within the Store Points Foresight Screen. If you are set to the

graphical icons in **Configure**, you would select the "offset to tree"  icon. This works from both the Graphic and Text screens when foresighting. There is no distinct total station "Offset" command—it is an offshoot (literally) of standard Store Points.

The Offset command includes the Read option to take a fresh measurement, to which the offset options then apply. Most users select O for Offset to do both the new measurement and the offset entries. However, you also have the option to apply the offset entries to the last measurement taken in Store Points. For this second alternate approach, you use the normal Store Points command to do R for Read or S for Store (or Enter to take the measurement) and then use the O for Offset command to use the last measurement (as displayed) and apply the offset options and click Store. In this second approach, if you chose R for Read and took a reading, and then selected O for Offset, you can then offset that reading with the option to store or not store the initial Read measurement. If you enter the Offset command after storing a point in Store Points, the last measurement will be used (and used for the Distance in the Distance/Angle, 2-reading option), and a new point ID will be stored. Within Offset, whenever you do a fresh, new Read, you will substitute the new reading for the one previously stored in memory. If you have no previous measurement, a new Read is required within O for Offset. So, in summary, you can offset something you've already measured, or you can take a fresh measurement (typical method), using O for Offset.

The total station Offset command must be selected each time it is used.



- **Distance/Angle** (sometimes referred to as “Shoot a Big Tree”): The Distance/Angle method requires two measurements. The first measurement is the distance, followed by the prompt to read the angle. Note that the dialog, shown in the next figure, prompts you to Read Distance first.

The screenshot shows the 'Offset' dialog box with the 'Dist/Ang' tab selected. The 'Record Vertical Angle from...' section has 'Dist Reading' selected. The 'Vertical Offset:' field is empty. The 'Pt:' field contains '13' and the 'Desc:' field contains 'EP'. The 'HT:' field contains '3.00 ft'. There is a checked box for 'Prism at angle rdg.'. At the bottom, there are three buttons: 'Read Distance', 'Read Angle', and 'Store'.

In the case of shooting a large tree, where the goal is to shoot the center of the tree, you would take a shot to the middle-side of the tree, equivalent to the distance to the center of the tree. Then you would take a second shot, as prompted, to the middle of the tree, for horizontal angle only. Note that for the elevation of the shot, you can use the distance measurement or the angle measurement (second reading), and apply the vertical offset, if any, accordingly. After both measurements are taken, the results are displayed. You are then returned to the dialog to take your next offset.

- **Point (Plus/Minus)**: The Point Offset takes a shot and deducts or adds a distance relative to the line-of-sight in all three directions (L/R, In/Out, Vertically Up/Down) using the dialog shown in the next figure.

The screenshot shows the 'Offset' dialog box with the 'Point' tab selected. The 'Relative Instrument Facing Point' section has 'Out', 'Right', and 'Up' selected. The 'Value:' fields contain '1.500 ft', '1.500 ft', and '3.100 ft' respectively. The 'Pt:' field contains '13' and the 'Desc:' field contains 'EP'. The 'HT:' field contains '3.00 ft'. Below this, the 'Measured:' section shows 'AR: 15°00'00"', 'ZE: 90°00'00"', and 'SD: 55,000ft'. At the bottom, there are two buttons: 'Read' and 'Store'.



- Before the shot, tap **Read**. After the shot, when the raw data is displayed in the lower left, tap **Store**. You will remain in the command until you tap **Close**.

### Repeat Shots Using Offsets

When taking multiple measurements in traffic or other conditions where you must move away quickly, one technique is to use the Offset button in Store Points, and then the Point method. You do a Read and enter 0 for all offsets, then Store. Then change the description and tap Store again (no additional Read is necessary), and a second point with a different description (or rod height or offset) is stored. Some office software programs require distinct readings on the same point to process multiple descriptions, in which case the use of Offsets to store multiple readings with one field measurement is recommended.

The screenshot shows the 'Offset' application interface. At the top, there are icons for a globe and a back arrow. Below that are four tabs: 'Dist/Ang', 'Point', '2 Point' (which is highlighted), and 'Ang Rdgs'. The main area is titled 'Create Vector'. It contains two sections for reading prisms. The first section, 'Read Prism 1', has a dropdown menu set to 'Use 2-Prism Pole' and three input fields for North (N), East (E), and Vertical (Z) offsets, all with units in meters (m). The 'A' value is entered as 0.33 m. The second section, 'Read Prism 2', also has three input fields for N, E, and Z offsets, with 'B' entered as 2.00 m. At the bottom left, there are fields for 'Point:' (containing '6') and 'Desc:'. To the right of these fields is a small icon with 'A', 'B', and 'C' labels. On the far right, there is a 'Store' button. On the right side of the interface, there is a diagram showing a 3D vector. A red line represents the vector from point P2 to point P1. Point P1 is at the top, and point P2 is at the bottom. A horizontal line segment 'A' and a vertical line segment 'B' are shown to illustrate the components of the vector.

- **2-Point Offset:** This creates a 2-point 3D “vector”, where the offset direction, distance, and vertical offset are computed from the delta N, delta E and Delta Z of the two points that are measured or entered. If **Read Inst** is enabled, then the two points are measured in the field. If, instead, you wish to obtain the offset vector from two points, then disable **Read Inst** and enter the two point numbers. The offset entered will extend the vector from point “P2” in the direction of “P1” to “P2”. The vector offset will also impact the elevation that is calculated. This might be used to calculate a point at the top of a cliff, for example, where you stand above the cliff top, pick up two points on the slope to the cliff edge, and estimate the distance to the cliff face from the second point. The offset by two points routine will write an SS record in the RW5 file (raw file), which enables re-processing.



The screenshot shows the 'Offset' software interface with the 'Ang Rdgs' tab selected. The interface includes a top navigation bar with a yellow hard hat icon, the title 'Offset', and three icons: a globe, a left arrow, and a right arrow. Below the navigation bar are four tabs: 'Dist/Ang', 'Point', '2 Point', and 'Ang Rdgs'. The 'Ang Rdgs' tab is active. The main area contains three input fields: 'Point' with a blue cursor, 'Hgt' with the value '0.00' and a unit 'ft' dropdown, and 'Desc' with the value 'EP' and a menu icon. At the bottom right, there are two buttons: 'Read' and 'Store'.

- **Angle Readings:** This allows for angle-only measurements to be stored in the RW5 file.

The screenshot shows the 'Offset' software interface with the 'Settings' tab selected. The interface includes a top navigation bar with a yellow hard hat icon, the title 'Offset', and three icons: a globe, a left arrow, and a right arrow. Below the navigation bar are four tabs: 'Dist/Ang', 'Point', '2 Point', 'Ang Rdgs', and 'Settings'. The 'Settings' tab is active. The main area contains three sections: 'Laser Settings', 'Robotics', and a checkbox labeled 'Read target height from laser' which is checked.

- **Settings:** The Settings tab appears with robotic total stations running remotely (from the prism) and permits reading the target height from a laser and accesses the entire range of laser devices found in the **Peripherals** menu option under **Equip**.



## 6.8 Store Points (GPS)



Store Points is the principal data collection routine for GPS equipment. Store Points interacts with numerous settings, including the feature codes, and will draw line work. The Store Points screen in GPS shows the cursor moving on the screen in real-time. Measurements can be taken anytime by pressing **Enter**. The screen will pan automatically, so you are always in view as you move. Points will plot on the screen as shots are taken. See File, Feature Code List, for discussion of drawing linework, symbols, Line Details and Point Details (option to re-measure existing points).

In GPS mode, **Enter** has only one function: Read & Store. The after-shot antenna height and description prompt can be enabled in **Configure** (C or ALT-C from the Store Points screen.). If you don't have the height and description prompt turned on, then each shot is a single press of **Enter**, and you must enter antenna height, description, or point ID changes prior to pressing **Enter** and taking the shot.

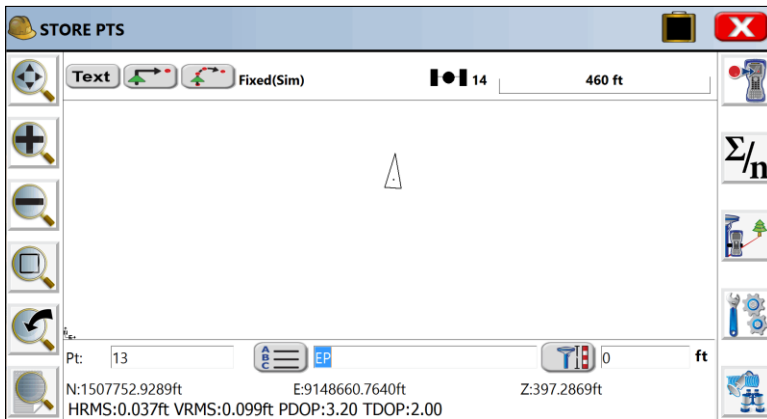

For GPS, coordinates, status (Fixed, Float, Autonomous) and HRMS and VRMS accuracy estimates are displayed at all times. The icons at the left are for zooming and panning. From top to bottom, they are: zoom extents, zoom in, zoom out, zoom window, zoom previous and point display control.



If you prefer to work in a pure text screen, without graphics, you can tap the helmet icon and select Text (or Text if that option has been selected in Job Settings). The following dialog will appear.

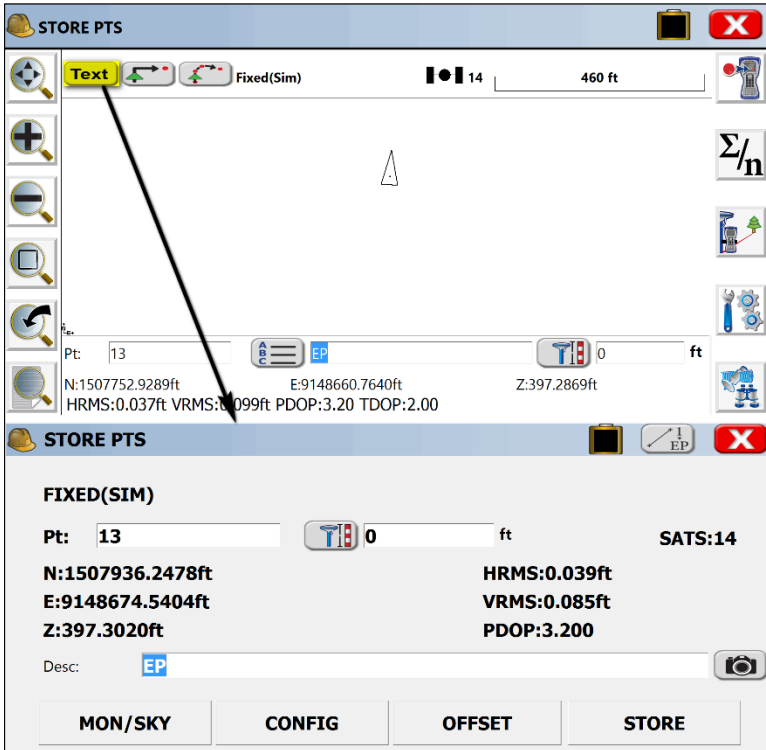

Another feature of Text mode is that when you enter a description, the program uses the full screen to display available descriptions and automatically scrolls to the descriptions that begin with the letters or numbers that have been entered. In the example below, the entry of "e" scrolls to the descriptions beginning with e (EBOX).

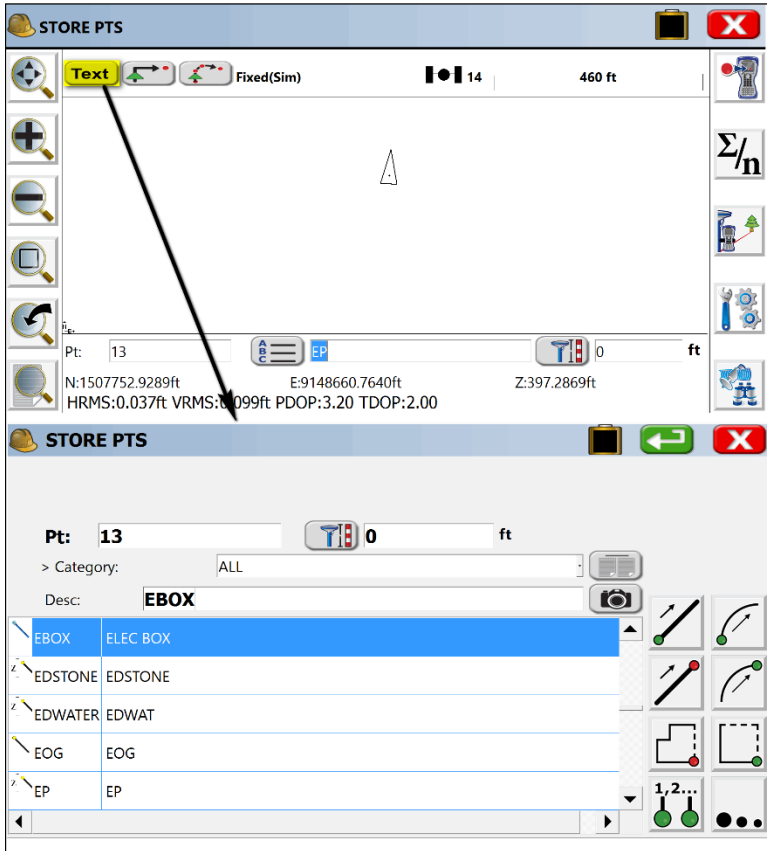

The Text screen uses a large character size for easy viewing, and limits options to Monitor/Skysplot, Configuration, Offset, and Store. You can return to the graph view by tapping the GRAPH button. You can also temporarily view your points on the screen by tapping Map, then tap Back to return to the text-based data collection screen. Note that the program will remember which screen you were in last (Graph or Text) and return to that mode of data collection automatically.





**Snaps** are available for the user by clicking on the ‘i’ icon.

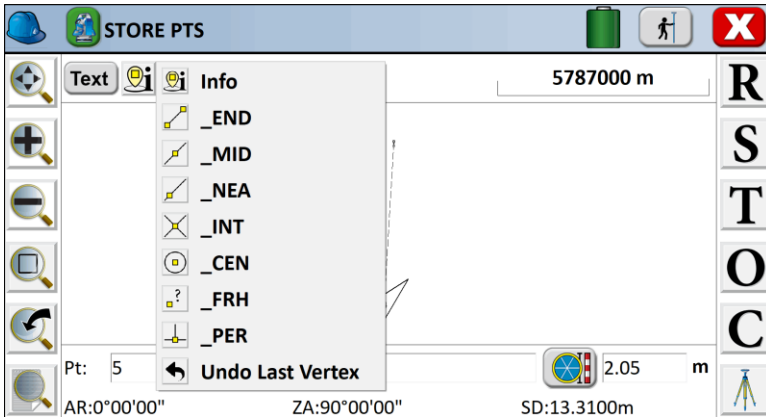

In addition to pressing **Enter**, Points can be Stored by selecting this icon (ALT-S). If a point is stored using a point ID that has already been used, the user will be presented the Point Protect screen.

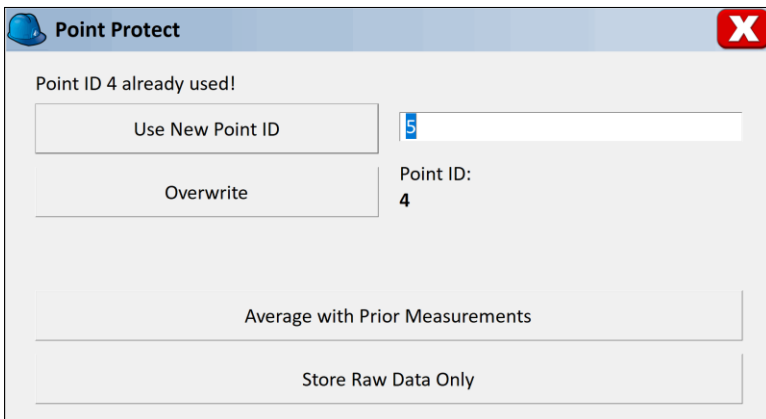

The Point Protect screen allows the user to select a new point ID or overwrite the currently saved point information for the selected point ID. The Average with Prior Measurements is selected, the software will check the distance between the new coordinates and the existing coordinates. If this distance is greater than 10cm, the user will be prompted to confirm to continue with the average. The prompt is meant to avoid averaging to the wrong point.



## Average

With GPS, since shots tend to cluster around the true point location, it may be preferred to **Average** 10 or more GPS readings when taking measurements. You will be prompted for how many readings to take (up to 999). Taking 100 readings is also a way to gauge how fast your GPS equipment takes measurements. If 100 readings are taken in 20 seconds, you are reading at 5 per second, or 5 hertz (hz). After the readings are taken, a display appears showing the range and standard deviation of the readings. If IMU is enabled and calibrated, the average position will adjust for the tilt of the pole and average calculated ground coordinates.

SurvPC will include a line in the RW5 file to report the min, max, and average latency when using the average routine.

**Average GPS** [Checkmark] [X]

Number of Epochs

Time in minutes

Ignore invalid readings

Always Display Average Statistics

Beep on rejected rdgs  Log Avg. Observations

Repeat every  mins. for  hrs.

SATS:16/17 Status:FIXED(Sim)  
HRMS:0.018m VRMS:0.033m

Configure | Tolerances | Monitor/Skyplot

**Average GPS**

Taking Reading #4 of 10  
4 Valid readings recorded.

SD.North: 0.0313 SD.Elev: 0.0008  
SD.East: 0.0177

SATS:14 STATUS:FIXED(Sim)  
HRMS:0.044ft VRMS:0.112ft

Stop Averaging and Store | Cancel Averaging



**Average Results** ✓ ✗

Valid Readings:	10/10	
Fixed:	10/10	
	Average	StdDev
North:	1508733.038ft	0.0404ft
East:	9148734.447ft	0.0250ft
Elev:	397.284ft	0.0008ft
	Min	Max



### Offsets

This icon leads to **Offset** reading screens with options for keyed-in offsets as well as offsets taken by laser devices. These devices can measure distance only or distance and azimuth (ALT-O). See [Store Points \(GPS Offsets\)](#) for more details.

**Distance/Angle** 🌐 ←

Laser **Offset** Results Method

Horz Offset:  ft

Offset Azimuth:  °

Vertical Offset:  ft

AZ Reference  
 North  
 Pt

Read GPS Store

N: 1508766.4699ft      E: 9148736.9214ft      Z: 397.290ft  
HRMS: 0.049ft      VRMS: 0.083ft      FIXED(Sim)



## Configure

This icon will take you to the **Configure** dialog, also found on the EQUIP tab. From this dialog, you can set the number of readings to average, specify to only store fixed readings, and turn on or off the Hgt/Desc prompt on Save (ALT-C).

The screenshot shows the 'Configure' dialog box with the 'General' tab selected. The dialog has a title bar with a yellow icon, the text 'Configure', and green checkmark and red X buttons. Below the title bar are two tabs: 'General' (selected) and 'View'. The main area contains a list of checkboxes: 'Store Fixed Only (GPS)' (checked), 'Prompt for Total Station Setup' (checked), 'Prompt for Height & Description' (checked), 'Prompt for Point Notes' (checked), 'Prompt If Duplicate of Backsight or Last Reading (TS)' (unchecked), '3D Mode' (checked), and 'Use Virtual Keyboard' (unchecked). Below the list are two input fields: 'No. of Readings to Avg -' with 'TS:' and 'GPS:' labels, both containing the value '1'. At the bottom are two dropdown menus: 'Enter/Store Icon - TS:' and 'Enter/Store Icon - RTS/GPS:', both set to 'Read & Store'.

The screenshot shows the 'Configure' dialog box with the 'View' tab selected. The dialog has a title bar with a yellow icon, the text 'Configure', and green checkmark and red X buttons. Below the title bar are two tabs: 'General' and 'View' (selected). The main area contains two dropdown menus: 'Method:' set to 'Direction L/R & Distance' and 'Coding Style' set to 'Classic'. Below these are two more dropdown menus: 'Display:' set to 'Grid' and 'Speed' (unchecked), and 'Declination' (unchecked) and 'ETA' (unchecked).



## Monitor/SkyPlot

This icon will take you to the Monitor/SkyPlot screen for GPS status, coordinates and Lat/Long display (ALT-D).

Quality	Position	SATView	SATInfo	Ref
Status:	FIXED(Sim)		Satellites:	14
			Local Elev.:	397.3109ft
Local Northing:		1507682.4216ft		03/28/2017
Local Easting:		9148655.4652ft		12:45:31.4
HDOP:	2.90	VDOP:	3.80	
TDOP:	2.00	PDOP:	3.20	
GDOP:	3.77			
HRMS:	0.030ft			
VRMS:	0.042ft			

## Height/Description Prompt and Camera Feature

Within Configure, you can turn on the Height/Description Prompt which provides an extra screen after the point measurement to verify all data such as antenna height and description, with the full list of selected feature codes available to choose from, as well as icons for special codes such as Start Curve, End Curve, Close, etc. If the PC has a camera feature, the camera option is also specifically available in the Height/Description Prompt screen. So, to utilize the camera option, there are two prerequisites: (1) The PC itself must have a built-in camera feature accessible by SurvPC, and (2) Prompt for Height & Description must be turned on.

General	View
<input checked="" type="checkbox"/> Store Fixed Only (GPS)	
<input checked="" type="checkbox"/> Prompt for Total Station Setup	
<input checked="" type="checkbox"/> Prompt for Height & Description	
<input checked="" type="checkbox"/> Prompt for Point Notes	
<input type="checkbox"/> Prompt If Duplicate of Backsight or Last Reading (TS)	
<input checked="" type="checkbox"/> 3D Mode	
<input type="checkbox"/> Use Virtual Keyboard	
No. of Readings to Avg -	TS: 1 GPS: 1
Enter/Store Icon - TS:	Read & Store
Enter/Store Icon - RTS/GPS:	Read & Store

The use of the camera feature within Store Points (GPS) is described below. Photographs in SurvPC can be associated, as GIS data, with the measured point and description. Within Store Point, in the Height/Description Prompt screen below, a camera icon appears next to the Description edit box, if properly configured.

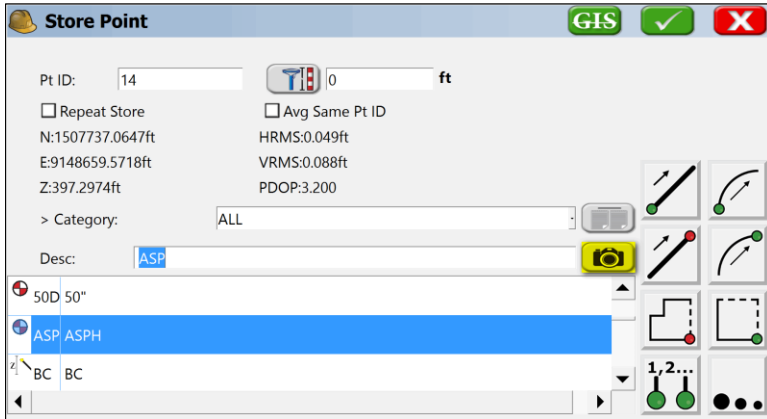

To add photographs to a point (e.g. point 1194) or line, click the camera button.

### **Photograph Gallery**

In SurvPC multiple photographs can be associated with a point or line. In the Photograph Gallery a photograph can be captured or selected.

### **Take a Picture**

To take a picture click the Capture button to launch the camera program. This will use the camera on the PC.

### **Select a Picture**

Browse existing photographs by clicking on the Select button. These photographs will be copied to the job Photograph folder and linked to the point.

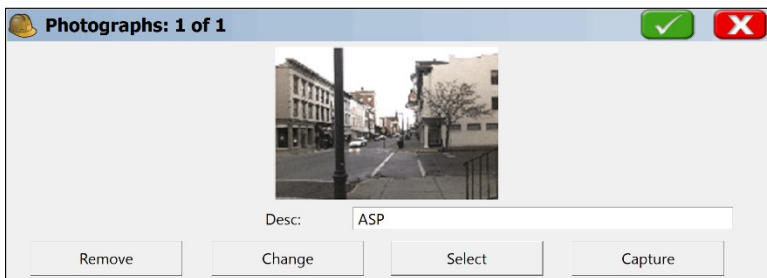

### **Capture Leads to Camera Program in Windows**

To display your camera options and features pick the menu button. The camera options shown are for a Microsoft Surface PC. These will vary by make and model of PC.

To close and save the photograph click OK on the screen or press OK on the PC.



## 6.9 Store Points (GPS Offsets)



The GPS Offset command allows you to calculate and store points by specifying an offset from a GPS position. Offsets can either be entered manually or read automatically from a laser. There are three GPS offset methods: Distance/Angle, Intersection, and Two Point. The current method can be set from the Method tab.

The screenshot shows the 'Distance/Angle' method selection screen. The title bar reads 'Distance/Angle' with a globe icon and a back arrow. Below the title bar are four tabs: 'Laser', 'Offset', 'Results', and 'Method'. The 'Method' tab is selected and highlighted. Underneath the tabs are three buttons: 'Distance/Angle', 'Intersect', and '2 Point'.

### Distance/Angle Offset

In the Distance/Angle method, offsets can be specified manually by choosing the OFFSET tab, or with a laser, by choosing the LASER tab.

- **Manual Offset:** Under the OFFSET tab, offsets are specified by entering azimuth, vertical, and horizontal distance offset values as show below. The azimuth can either be specified with respect to north, or with respect to a specified point. Current GPS coordinates are shown at the bottom and can be updated via the **Read GPS** button. When all necessary data has been entered, you'll be able to store by tapping **Store**, or preview the point you're storing by selecting **Map**, or **Results**.

The screenshot shows the 'Offset' tab selected in the 'Distance/Angle' method screen. The title bar is the same. The tabs are 'Laser', 'Offset', 'Results', and 'Method', with 'Offset' highlighted. The main area contains three input fields: 'Horz Offset:' with a text box and 'ft' unit, 'Offset Azimuth:' with a text box and '°' unit, and 'Vertical Offset:' with a text box and 'ft' unit. To the right of these fields is an 'AZ Reference' section with two radio buttons: 'North' (selected) and 'Pt'. Below the input fields are two buttons: 'Read GPS' and 'Store'. At the bottom of the screen, the current GPS coordinates are displayed: N: 1508502.0682ft, E: 9148717.0566ft, Z: 397.296ft, HRMS: 0.045ft, VRMS: 0.100ft, and FIXED(Sim).



- **Laser Offset:** For more accurate offsets, lasers can be used for either the distance (with direction and vertical offset entered by the user) or for both distance and direction (where the laser gun includes compass directions). The Leica Disto, for example, provides distance only. The Laser Atlanta provides both distance and direction. Laser measurements are popular on construction sites and mine sites where it is dangerous to stand beneath highwalls and unstable rock conditions. Readings are taken from a safe location to the rock or dirt face. They are also useful for utility pole surveying and other forms of “windshield” surveys. The laser devices are often mounted on the pole beneath the GPS antenna. Special poles are available that offset around the lasers, allowing them to mount vertically, in-line with the center of the pole. If the antenna height is 2.5 meters, and the laser is mounted 0.7 meters below the antenna and 1.8 meters above the ground, you would enter 1.8 as the laser height. Laser types and laser height are set by clicking **Settings** in the LASER tab within **Offset**. This takes you to the same screen as can be found from the main menu on the EQUIP tab, under Peripherals. Under the LASER tab, offsets are read automatically from the laser attached to the serial port. Upon triggering the laser, you will see the reading displayed in terms of five parameters: Horizontal Offset, Vertical Offset, Slope Offset, Azimuth, and Zenith Angle, as shown below. The azimuth can either be specified with respect to north, or with respect to a specified point. Current GPS coordinates are shown at the bottom, and can be updated with the **Read GPS** button, or you can choose to have the GPS position read automatically before each point store by choosing Settings and enabling **Auto GPS Update**. When all necessary data has been entered, you’ll be able to store by clicking Store, or preview the point you’re storing by clicking **Map** or **Results**. Before you can begin using the Laser offset feature, you must configure the laser, either by clicking **Settings**, or by selecting **Peripherals** from SurvPC’s main menu. Under the peripherals menu, you will have to activate your laser, select your laser type, and choose a COM port. It is also recommended that you deactivate all other peripherals except GPS while using the laser. For more details on laser setup, see the [Peripherals section](#) of this manual. Once you have activated a laser, you may click **Read Laser** to begin collecting data from the laser. In order to expedite the data collection process, the methodology for reading an offset from the laser has been optimized so that you do not need to touch your PC between shots. This option can be enabled by selecting **Multiread Laser**. If you are a first-time user, it is recommended that you disable this option. If Multiread Laser is disabled, pressing **Read Laser** will pop up a dialog asking you to trigger the laser, as shown below. From here, you can either cancel, or fire the laser to record the shot. If Multiread Laser is enabled, when you press Read Laser, a dialog will appear asking you to trigger the laser, as shown below. Each time you trigger the laser, a new shot will be collected, and if there was a previous shot, it will be automatically stored. Between shots, the laser reading and the offset-adjusted position to be stored are displayed. If Auto GPS Update is enabled during peripheral setup, a new GPS position will be read for each shot. If a bad reading is taken, you can prevent it from being stored by pressing **Reject Last Shot**. When finished, click **Exit Shot Sequence**.





**Distance/Angle**

**Laser** | Offset | Results | Method

Horz Offset:

Vertical Offset:

Azimuth:

Distance:

Zenith Angle:

Multiread Laser

AZ Reference

North

Pt

Get Point | Read Laser | Read GPS | Store

N: 1508502.068ft      E: 9148717.057ft      Z: 397.296ft  
HRMS: 0.045ft      VRMS: 0.100ft      FIXED(Sim)

- **Results:** Before storing, you can preview the data by selecting the RESULTS tab. If valid data has been entered in the LASER or OFFSET tab, the result will appear as shown below. In this window, you can also change the GPS antenna height, or specify a vertical difference for your target point. You can also specify the point ID and description for the point that will be stored.



## Offset by Intersection

Use Offset by Intersection to calculate a point based on two GPS positions and two distance offsets. The distance values can either be manually entered or input with a laser. To use a laser, you must first activate it by selecting Settings. For more information on laser setup, see the Peripherals section of this manual.

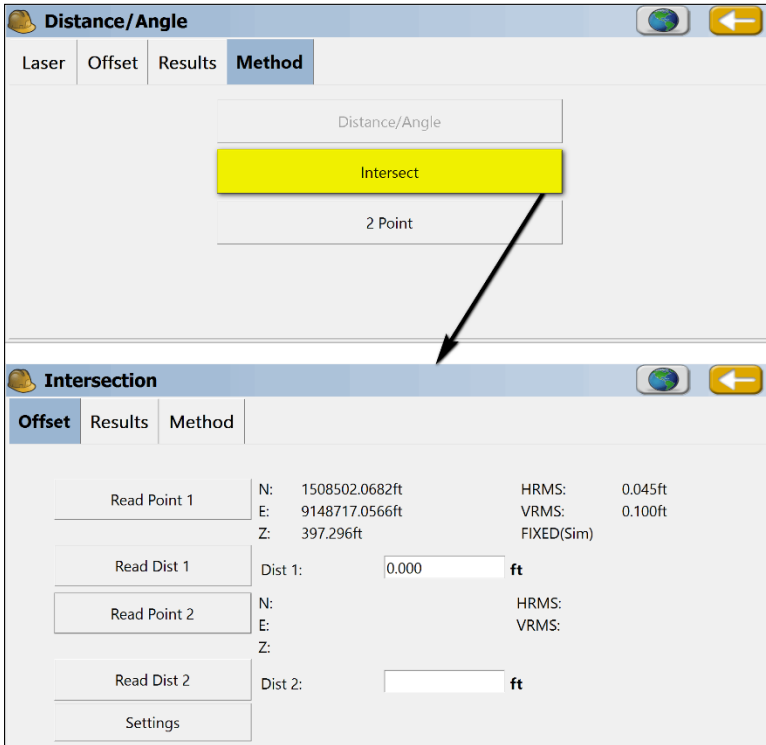

- **Offset:** Under the OFFSET tab, press **Read Point 1** to read the first point from GPS. Now enter the distance of the point to be stored, or press **Read Dist 1** to read this distance from a laser. Repeat this process for the second point. Switch to the RESULTS tab to see your solution. If your distances and GPS can't be triangulated, you may have to return to this tab to adjust the values.
- **Results:** After you have two GPS positions and two distances that form a valid triangle, click on the RESULTS tab to view the resulting point. If valid data has been entered in the OFFSET tab, the result will appear as shown below. In this window, you can adjust the GPS antenna height, or specify a vertical difference for your target point. You can also specify the point ID and description for the point that will be stored. The intersection method generates two solutions, so you will have to select which one you want by clicking the appropriate radio button.

## Offset by Two Point

Use Offset by Two Point to calculate a point based on two GPS positions and a distance from the second point. If **Straight** is selected (lower right dropdown), the distance



offset from the second point is along the 3-D vector created by the two GPS points. If **Left** or **Right** is selected, the offset is perpendicular to the 2-D vector created by the two GPS points, and the second point's elevation is used as the elevation of the resulting point. The distance offset can either be manually entered or input with a laser. To use a laser, you must first activate it by selecting **Settings**. For more information on laser setup, see the [Peripherals](#) section of this manual.

Read Point 1		N:	1508517.9323ft	HRMS:	0.043ft
HT:	6.543 ft	E:	9148718.2486ft	VRMS:	0.085ft
		Z:	390.758ft	FIXED(Sim)	
Read Point 2		N:		HRMS:	
HT:	6.543 ft	E:		VRMS:	
		Z:			
Offset:				Straight	

- **Offset:** Under the Offset tab, press **Read Point 1** to read the first point from GPS. Repeat this process for the second point. The GPS antenna height used for each GPS read can be adjusted individually by editing the HT fields. Now enter the offset of the point you would like to store, or press **Read Dist** to read it from a laser. Finally, specify the direction of your offset, and switch to the RESULTS tab to see your solution.
- **Results:** After you have two GPS positions and an offset, click on the RESULTS tab to view the resulting point. If valid data has been entered in the OFFSET tab, the result will appear. In this window, you can specify a vertical difference for your target point. You can also specify the point ID and description for the point that will be stored.





## 6.10 Stake Points



This command allows you to stakeout a selected point by guiding you to the point with a series of commands and directions. The point can be a Point ID or the endpoint, mid-point, intersect or other "snapped" point on a map (using the Map icon). Various options can be set in EQUIP, Configure, View Point to adjust how the directions are provided to best suit your needs. The Tools icon or C to Configure also will access the View Point settings. You should also review the Job Settings under FILE before staking. The dialogs are varied slightly with respect to total station or GPS equipment. Both types are documented here, illustrating the differences between the dialogs.

**Stake Points**

Point ID:   

Point by Direction  
 Obstructed Point

Azimuth:

Slope:

Northing:  ft

Easting:  ft

Elevation:  ft

> H. Distance:

Description:

*Note: While in graphics mode stakeout, if you press the down - arrow key, you can increase the plan view size and eliminate some of the text information. Pressing the up-arrow key again reveals the cut and fill.*

After selecting OK, the main stakeout window appears in MAP view. In manual total station mode, the angle to turn to and the distance to the stake point will be displayed at the bottom of the screen.



Shown below are the graphic icons, set under EQUIP, Configure, using GPS Simulator.

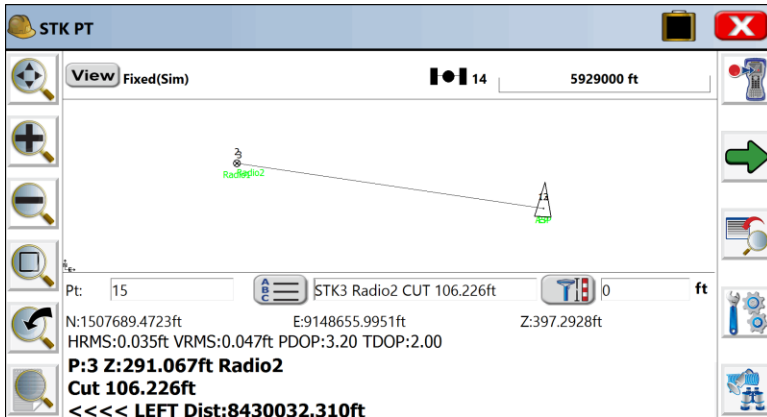

A read function is required to update the directional display information. You should see your points in the map with an icon showing your target location (the circle with the X inside).

Measurements are taken typically by pressing **Enter**. **Enter** also transitions automatically from the Stake Points entry screen to the Stk Pt measurement screens above. Point Stakeout can be conducted without touching the screen, using the Enter key and entering point IDs using the keyboard. Both screens are explained below, starting with the graphic Stk Pt screen.

- **Stake Points – Obstructed Point**

Stake Point using the Obstructed Point method allows the user to stake to a point that is in some manner not possible to survey; such as a car over a manhole. The method proceeds with the user storing a point away from the obstructed point to establish a line. Once this line is established, the user can stake a point anywhere on that line and the software will output the distance to the obstructed point. The process is as follows:

- Select Obstructed Point from the Stake Points menu.
- Select the obstructed point from the point list.
- Store a point to establish an orientation line between that point and the obstructed point.

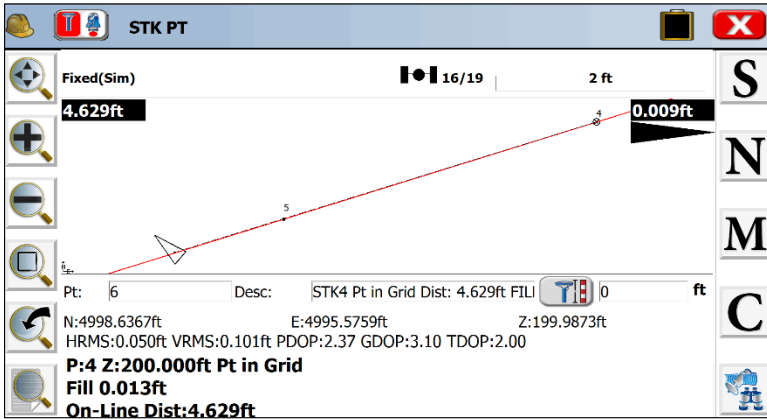

- Navigate to that line (which will turn green once within the stakeout tolerances) and store the point.

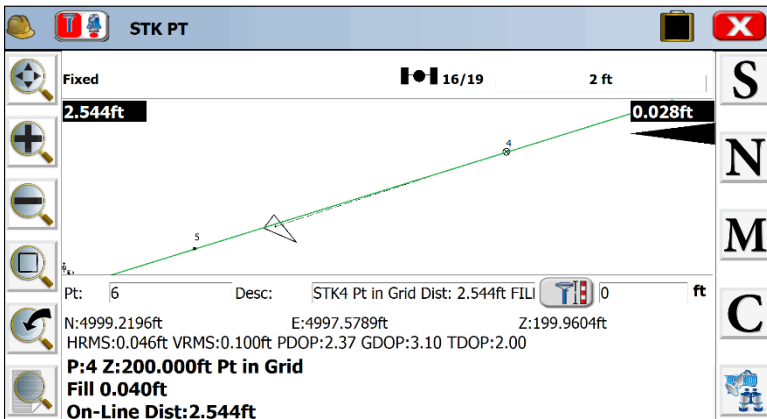

- The Obstructed Point Alignment screen will show the user the distance along that line the obstructed point can be found.



Obstructed Point Alignment			
Staked:	Northing(ft) 4983.773	Easting(ft) 5034.114	Elevation(ft) 199.982
Design:	5000.000	5000.000	200.000
Move:	On-Line	Dist:37.777ft	Fill 0.018ft
VOff 1:	<input type="text"/> ft	Elev:	<input type="text"/> ft
VOff 2:	<input type="text"/> ft	Elev:	<input type="text"/> ft
HRMS:0.038ft	VRMS:0.098ft	PDOP:2.371	
<input checked="" type="checkbox"/> Store Point	Point ID:	<input type="text" value="6"/>	
Point Description:	<input type="text" value="STK4 Pt in Grid Dist: 37.777ft"/>		

- **Total Station or Robotic Total Station running Direct:** After reading and taking the shot, the display will be updated with a distance and direction to the stakeout point. Buttons on the right from top to bottom are Read, Store, Next, Menu, Configure and Setup. Enter is treated as R for Read. Pressing S (or "Store to Collector" icon, 2nd from top right) will go to the Stakeout Report screen and allow you to write to the "cutsheet" file the cuts and fills and optionally to store the measurement as a new point ID.

STK PT	
<b>View</b> Turn: 47°40'32"	380 ft
Pt: <input type="text" value="15"/>	<input type="text" value="3"/> ft
AR: ...	ZA: ...
<b>P:3 Z:291.067ft Radio2</b>	
<b>Turn to AR: 47°40'32"</b>	
<b>Move Out 476.549ft</b>	

- **GPS or Robotic Total Station with Tracking On:** Your current position is read immediately (no Read button needed). R takes a fresh reading. If you press **R** for **Read** or **S** for **Store**, you will go to the **Stakeout Report** Screen. **Enter** is treated as **R** for **Read** and takes a fresh reading, then proceeds to the **Stakeout Report** screen. If you are outside of accuracy tolerance, you will be warned and asked if you wish to proceed. In the **Stakeout Report** screen, you can save your cut and fill data to a cutsheet file and optionally store a new point ID based on the fresh measurement taken. If you click off tracking, then the angle to turn for staking is



displayed, same as with regular total stations running direct. With robotic total stations, if you are locked on and tracking, you will see instantaneous instructions on directions to move to the point, meaning that you do not need to take a reading to locate the point. Just move to the point based on the instructions. If the screen is not updating, it is recommended to turn off lock and then re-acquire lock by tapping the lock icon twice, verifying that tracking also is on. Then the instructions to move will stream in real-time.

- **Robotic and Motorized Total Stations, "Turn to Point":** In Total Station, Search Tab (Equip menu, or accessible through the tripod icon or C for Configure), you can turn on "Turn to Horizontal" in Stakeout. If this is turned on, the instrument will turn to the target point automatically. If "Turn to Vertical" is also on, and the correct target height is entered, the instrument will turn to both the horizontal and vertical position of the target. Do not use "Turn to Vertical" if the elevation of the target point is 0 or not accurate.
- **Point ID:** This is the point which you are staking. You can enter it in here and hit the **Enter** key to view the elevation, northing and easting before selecting **OK**. If you want to stake out a range of points, you can enter in the points in the following format: 3-10,2,15-20. This would stake out the points from 3-10 sequentially, then point 2, then 15 through 20 sequentially. N for Next would move to the next point in the list. If you are using a control file in total station mode, and you enter a point number which also is present in the current job file, it will choose the control file point if **Control File Has Priority** is enabled in the stakeout section of **Job Settings**. If you enter a point number that is not in the control file, but is in the current job's coordinate file, then that point will be used. You can also select the points to stakeout from a list by selecting the **List** icon. If you select the List option, you can select the points for stakeout from the active job file or the control file. To do this, you must toggle between the files using the **Job** and **Control** toggles at the top of the dialog. You can select a range of points by selecting the first point to stake then pressing the shift key and selecting the last point to stake. All points between the two selected points will be staked in sequential order. You can also add to the selection of points to be staked by pressing and holding the **CTRL** button and individually selecting the points to be staked. The final way to select an individual point to be staked is by selecting the **Map** icon and tapping on the point to be staked. Using the **Map** icon, you can also select points to stake from linework on the screen, using the endpoint, intersect and other "snaps".
- **Add to List, Pick from List:** When you select, or enter multiple points, they appear in the Point ID dialog window. You can then pick **Add to List** and create a list of these points in the order they were selected. When you Add to List, the Point ID dialog is cleared, and you can select more points, place them in the dialog and click Add to List again. Then you can stake any of them using **Pick from List**, where the points appear as shown below:





Point Details						
Point ID	Northing(ft)	Easting(ft)	Elevation(ft)	Description	Point ID	
2	2734379.45	808827.41	251.083	Radio1	2	
3	2734374.23	808350.89	291.067	Radio2	3	
4	2734041.32	808526.18	224.493	MON1	4	
11	2734320.24	808746.82	247.783	EP	11	
12	1508193.60	9148693.88	397.308	EP	12	
13	1508733.04	9148734.45	397.284	ASP	13	
14	1507737.06	9148659.57	397.297	ASP	14	
15	2734350.34	808793.09	249.483	STK3 Radio2 FILL 41.584ft	15	

- **Source:** When you press **Enter** after selecting the point (or points), the program will display the source of the points, either as Current Job or Control File. The display of the source is important for verification. You may discover, for example, that someone has turned on **Control File Points have Priority** in the stakeout settings, and this is a way to catch the mistake.
- **Northing, Easting, Elevation:** You must have a northing, easting and elevation entered for the point you are staking out. If you type in the point number of an existing point and hit **OK**, these values will appear automatically. The description of existing points is displayed at the bottom of the dialog.
- **Point by Direction:** In addition to staking a point ID or entered coordinate, you can stake a point defined by a direction and distance, and even slope, from the entered point coordinate. This allows you to stake points without calculating point numbers or point IDs for the target point. Simply enter the bearing/azimuth, horizontal distance and also slope, if applicable. If the distance entry is not known but must be computed, the calculator is accessible from the distance dialog box by hitting the ? button. Shown below is a stakeout of a point calculated.

The screenshot shows the STK PT software interface. At the top, it says "STK PT" with a clipboard icon and a red 'X' icon. Below that is a "View" section showing a turn of 195°21'05" and a distance of 690 ft. The main area is a diagram showing a point labeled "11" with a distance of 150 ft to a point labeled "3". A dashed line connects point "11" to a point labeled "4". Below the diagram is a control panel with fields for "Pt: 16", "AR: ...", "ZA: ...", and "SD: ...". At the bottom, it displays "P:2 Z:251.083ft Radio1", "Turn to AR: 195°21'05\"", and "Move Out 100.000ft". The interface includes various navigation and tool icons on the left and right sides.



## N for Next (Increment Up or Down)

On some projects, you may find that it is more convenient to stakeout points in descending order.

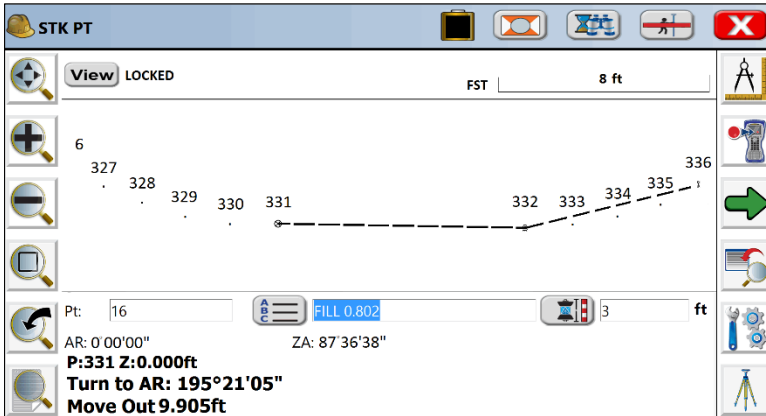

This can be accomplished by going to File, Job Settings, Stake tab, and switching to increment in descending order. If Increment ID Down is set, then N for Next would go to point ID 330, then to 329, etc.

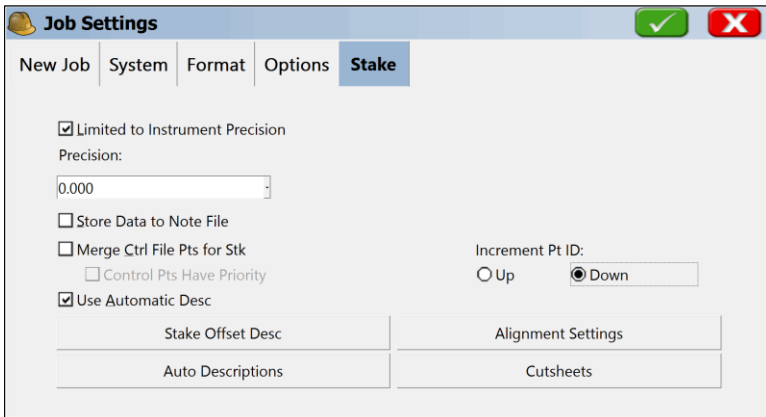



## View Pt

Depending on your settings in the **View Pt** tab of **Configure** (in the **EQUIP** tab), the direction to stake will either be Right/Left Distance, Azimuth and Distance, or North/South East/West Distances. The cut or fill is the elevation difference between the point read and the point being staked. Normally, you take a shot simply by pressing **Enter**. After a total station shot is taken, you will see your “In-Out” distance to the target point. For total station stakeout, the direction of the reference is shown by a little arrow in the lower right of the screen.

**Configure Stakeout Info**

General **View** Sets

Method: In-Out & Left-Right to Ref

Collapsed Report:   
Navigate Data   
Measurements   
Navigate Data   
None

Ref. Object: Instrument

Move Relative To: Ref. Object

Use CL for Ref. Object (when applicable)

Proximity STK(Pts)

## Stakeout Report Dialog

Selecting **S** to **Store** will display the Stakeout Report. You can turn off the **Store Point** option, and just reference the Stakeout Report screen for information. If the tolerance distance is exceeded for staking out, you will be notified and asked if you want to continue storing. (Stakeout Tolerances are set under Tolerances in the **EQUIP** menu).

**Stakeout Report**

	Northing(ft)	Easting(ft)	Elevation(ft)
Staked:	2734380.092	808822.451	249.483
Design:	2734379.450	808827.410	251.083

Move: In 5.000ft Right 0.000ft Fill 1.600ft

VOff 1:  ft Elev:  ft

VOff 2:  ft Elev:  ft

ZA:90°00'00" AR:8°00'00" SD:5.0000ft

Store Point Point ID: 16

Set GIS

STK2\_Radio1\_FILL\_1.600ft

The coordinates for the Stake Point and the Target Point are displayed. The delta North, East and the elevation difference (Cut/Fill) are also displayed. The vertical



offset input boxes allow for elevation calculations based on the input vertical offset values. The vertical offsets can be entered in inches in English units in two forms (10" using the inch designator, or 0.10.3.8 for 0 feet 10 and 3/8ths inches). The second form requires 3 decimals to be used.

If **Store Carlson Cutsheet Data** in Note File has been enabled, the vertical offset(s) specified will be recorded in the .not file for the job. If under **Set Cutsheet Format** in the Stakeout section of Job Settings, a Set Pt Cutsheet Format has been established with a named file for storage, then cut and fill data will be saved to a cutsheet ASCII file. If using GPS, the HRMS, VRMS, and PDOP values are also displayed. Fields for Point number and point description input are also displayed. If, for example, you choose not to store a staked point, but only report the design point, design elevation, surveyed elevation and the cut and fill, you could produce a simple cutsheet report as shown below. One vertical offset per shot was recorded (-10"). The cutsheet can be reviewed from within the active stakeout screen using Alt V. You can also click on the helmet and go to View Data to see the cutsheet report, while actively staking out, and you will be returned to the stakeout screen. Cutsheet data is always stored to the raw file, so if you forgot to store the cutsheet information, you could create a new point cutsheet file and select "Cutsheets from Raw File".

DesignPt	DesignEL	StakeEL	Cut
2	843.31	846.39	3.08
2 -0.83	842.48	846.39	3.91
13	842.47	846.39	3.92
13 -0.83	841.64	846.39	4.75
15	842.43	846.39	3.96
15 -0.83	841.60	846.39	4.79

Pressing **OK** (which optionally will Store Point if enabled) will return to the Stakeout Points dialog to select the next point for staking. If the Use Control File option is set under the Job Settings, you have the option of staking control file points. If you enter in a point number to store that is the same as a point number in the control file, the point in the control file will remain unchanged. It will only modify the point in the current coordinate file. If the point being stored is the same as one in the current job file, the **Point Protect** dialog box appears stating that the point you chose is already used. The next available point number is listed with the option to overwrite the current point or use the new number.

### Review of Stake Points Graphic Screen (Robotic Total Stations)

The Stake Points screens below illustrates many options available to the user when using a robotic total station.

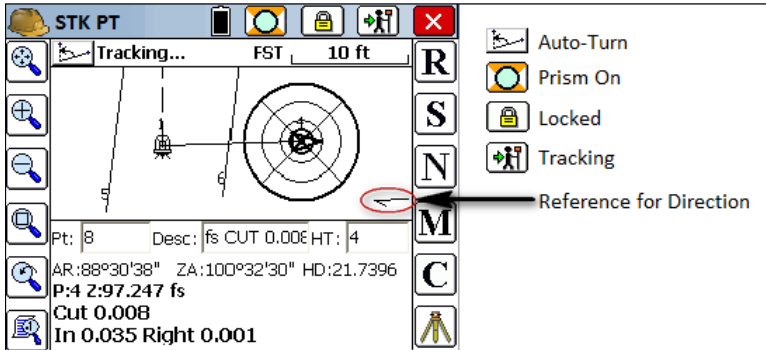

- **Auto Turn:** This option only appears if you are configured for a robotic total station with Turn to Horizontal set on in Search. Search can be accessed using the Tripod Icon (lower right) and selecting the Robotic tab, leading to Search or by clicking Total Station within Configuration and selecting the Search tab. Even C for Configure gives access to Search. Clicking Auto-Turn will turn the instrument to sight on the target point. If Turn to Vertical is also on, the instrument will sight the vertical position correctly, based on the target height. Do not use Turn to Vertical if the elevation of the target point is inaccurate or zero. Note that with Turn to Horizontal on, the instrument will do the turn automatically in stakeout. You only need to click Auto Turn if you want to force a new turn to the target if the instrument has been moved off the target.
- **Prism vs Reflectorless:** For total stations with reflectorless capability, a prism icon is displayed at the top of the screen which allows the user to toggle between prism and reflectorless mode.
- **Locked vs Search:** For robotic total stations, the lock and search (binoculars) icon is used to display the status of the instrument. When the lock is shown, the instrument is locked onto the target. If you press the lock icon, it will switch to Search mode. For Tracking to occur (distance measurements leading to known target position shown by triangle), the instrument must be locked. If the binoculars are shown, the instrument is in Search mode, and pressing the Search icon (binoculars) will start the search process, with the window of the search determined in Settings. When the prism is found after a search, it returns to lock mode.
- **Tracking:** Tracking is available with robotic total stations and indicates that distance measurements are being taken to the target. Tracking on leads to known position of the target, which then appears as a triangle. Tracking will use more battery life on the instrument. If turned off, the tracking off icon appears as a rodman with a line through it. With tracking off but lock on, the direction of the instrument typically appears as a line or beam radiating from the instrument position. In all stakeout routines, with tracking on and active, instantaneous, real-time instructions to move to the point are provided.



- **Reference Line for Direction:** The Left and Right instructions for direction to move are provided in reference to either a point or the instrument as set in View Point. This reference direction is shown in the lower right of the screen.

### Staking by Graphic "Pick Point" Selection

One of the interesting features of SurvPC point stakeout is the ability to stake to points on line elements without the creation of point numbers. You can just stake to the graphics using the "from Map" selection icon:  In this way, any drawing is a fertile field of available stakeout points, and complicated intersections involving spiral curves and other elements can be staked simply by using commands like Offset followed by snapping to intersections. Consider the example below:

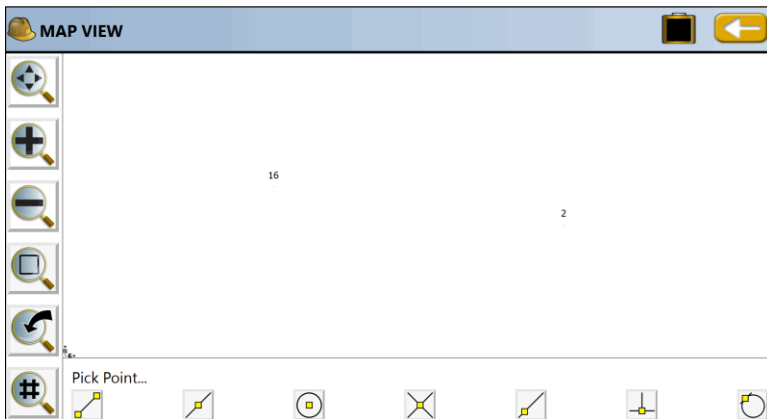

The road section from 234+00 to 236+00 is in a spiral curve and the goal is to intersect the right-of-way of the road, which is at a 50' offset from the centerline, with an original property line running NW to SE. Rather than use complicated coordinate geometry, the Map screen can be used to select Draw, Offset and create a 50' offset line of the road, shown above. Then within Stake Points, where point 17 is the occupied point and 18 is the backsight point, the point to stake can be selected using the  Map icon, and then the intersect snap (highlighted in gray above) can be used to find the intersect of the spiral curve to the property line. Note that the snap to the right of the intersect is the "nearest" snap--it picks up any point you pick on the linework, not necessarily at an endpoint or intersect point. Upon clicking the orange return arrow at the top right, the target point is computed. No target Point ID is created or is necessary. You can simply "stake to the drawing".

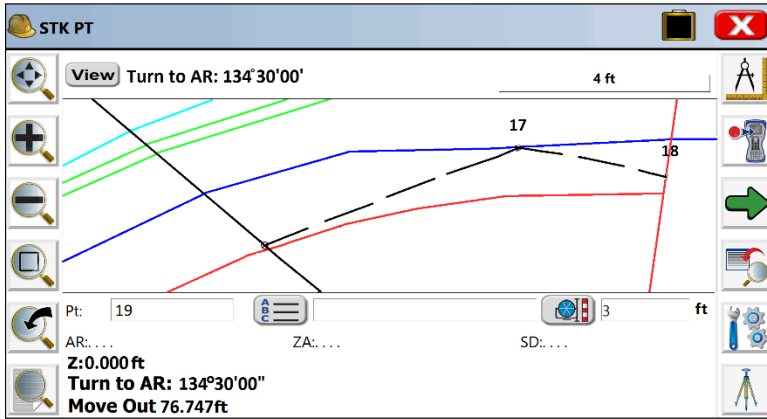

Using the graphic screen selection of points, you also have the ability to see the last point picked. So, if you are selecting a series of tightly-spaced "endpoints" of lines, using the endpoint snap, you can see your last point, and pick the next one, by reference.

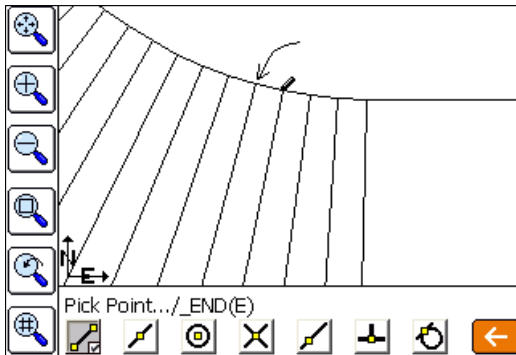

The last point selected is shown by a pencil, so if you are staking endpoints right-to-left, you select the next point shown illustrated here by an arrow. The previous "snap" used, such as "endpoint snap" highlighted above, is the default, allowing you to pick the next point immediately. If you don't pick a new point but instead click on the orange arrow, the program will default to the highlighted point (indicated by the pencil), and you will be re-staking the last point selected. So this option allows you to re-stake the last point and also reference the last point when staking another.

*Note: The graphics screen will show text such as stationing (e.g. 235+00) or lot numbers if the text is first converted to polylines before being imported as a DXF or DWG file. Carlson Survey, for example, has a command called "Text to Polylines" that can be used to convert standard text into polylines for presentation within SurvPC and other programs.*



## Using the Helmet Options

While in Stakeout, and without leaving the command, the Helmet can be used to access various reports and even conduct basic editing. When the Helmet (in the upper left) is clicked, the dropdown menu of "quick access" options appears:

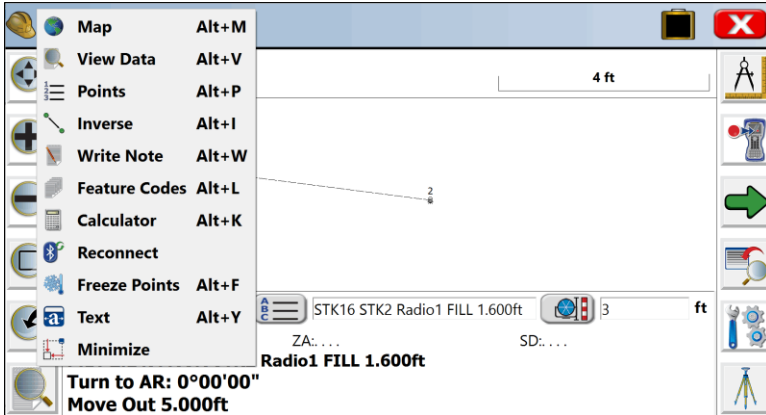

Some of the more useful commands to access, at any time, are Inverse (obtain 2D and 3D distance between points), View Data (review the cut and fill "cutsheets" and review and edit the raw file), Points (review the coordinates in the job file, delete and edit as desired) and Freeze Points (to freeze the point numbers and reduce clutter on the screen). The Calculator can be accessed to compute angles between points (triangle solution, pick 3 points), to compute math expressions and to convert between Lat/Long and grid coordinates, among other things. The "Reconnect" option is a quick way to reestablish the Bluetooth connection to the instrument.





### Graphics Screen Expansion: Normal (None), Navigate Data, Measurements

One of the special options available in Stakeout is the ability to maximize the graphics screen using the down - arrow to enlarge the graphics (reduce the lines of text instructions) and the up - arrow to return to normal graphics. Since the text instructions for stakeout are minimized in expanded graphic mode, you can control what content is provided in the one-line instruction by the setting in Viewpoint (Viewpoint tab within C for Configure, see discussion above). When the "Maximized Map" is set to None, then for total stations in direct mode, the instructions are the angle right to turn (top of screen) and the one-line display shows only the new point number and target/rod height. The screen at right is referred to as the "Maximized Map".

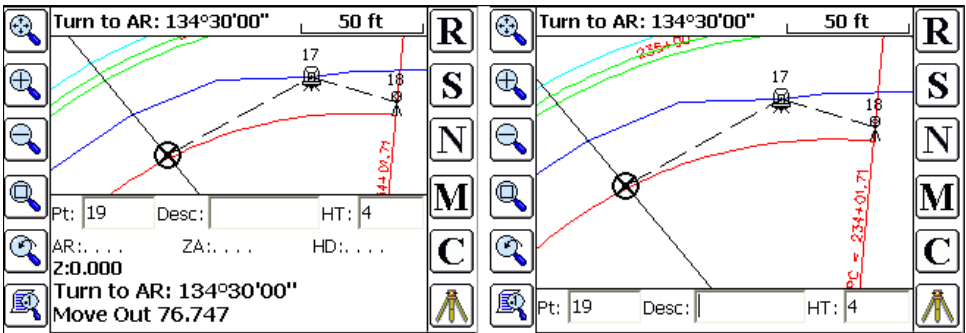

For robotic total stations in tracking mode and for GPS, the "None" setting in ViewPt, Maximized Map shows only the target and the lower line at right. In this case, the "Navigate Data" setting is beneficial. This adds an extra instruction line. Shown below is Stakeout with Navigate Data set for Maximized Map within ViewPt, running a robotic total station in tracking mode.

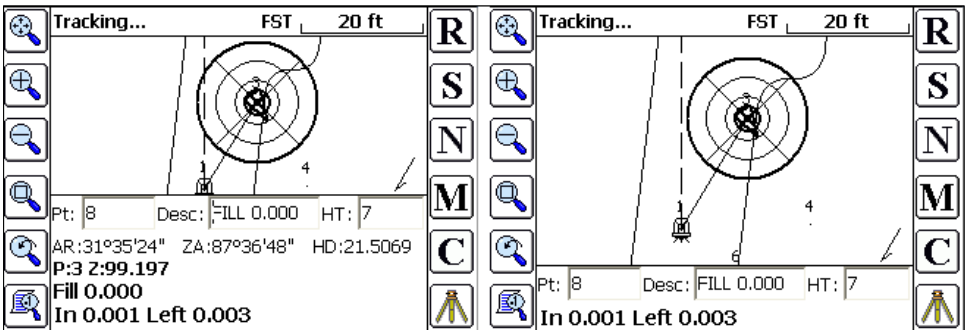



There is a third mode for the Maximized Map which is called "Measurements". With this mode set, and running a robotic total station, the larger map appears as shown below, with the current measurement data presented on a second line.

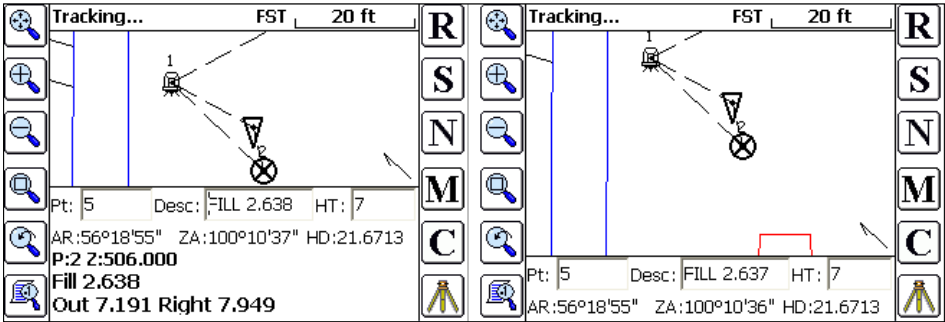

The expansion of the graphic screen in stakeout can be accomplished two ways: (1) press the down - arrow to expand, up - arrow to return to normal (at left) and (2) place your finger or stylus in the first line, near the "Desc" and pull - down and repeat the process and pull up the screen. (For restoring the full screen, the up - arrow is the easiest method).

### Stakeout Points using the Text Screen Mode

Some surveyors prefer a text screen for stakeout with no graphics and large, bold text characters. Using the Helmet, as described above, you can select "View" or enter Alt Y and go to Text mode for stakeout. The program then goes to a different display mode with larger text for improved readability, as shown here:

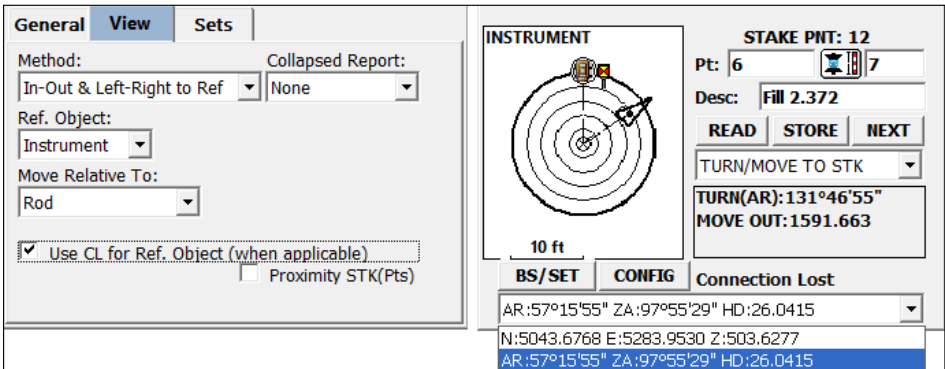



The instructions given are controlled by the settings in Configure, View Pt tab. In this case, the instructions are In-Out, Left-Right facing the instrument from the perspective of the rod or prism. This would be a typical configuration for running as a one-man crew working from the rod and facing a robotic total station. In the "bullseye" diagram, the target point is the center of the bullseye, the instrument is shown relative to the target point (which is at the top of the circle if due North) and the backsight is shown as a square target relative to the instrument. Your position is shown as a triangle, with tracking on (or with GPS). As you look at the instrument, you need to go Left to the center of the circle and back up or go Out. You can report the measurement or the actual coordinate based on the setting at the bottom of the screen, and your instructions can be set dynamically, within the stakeout screen, without needing to return to Configuration, by using the pulldown options in the middle right of the screen (current setting is In-Out, Left-Right). Your goal in Text mode is to get to the middle of the circle.

Another feature of Text mode is that when you enter a description, the program uses the full screen to display available descriptions and automatically scrolls to the descriptions that begin with the letters or numbers that have been entered. In the example below, the entry of "e" scrolls to the descriptions beginning with e (EBOX).

The screenshot shows a surveying software interface. At the top, it displays "View Form: 262°24'51" and a distance of "110 ft". Below this is a "View Pt" tab with a bullseye diagram. The diagram shows a central point, a square target, and a triangle representing the instrument. To the right of the diagram is a "STAKE PNT: 398" section with fields for "Pt: 1042", "Desc: Ave", and buttons for "READ", "STORE", and "NEXT". Below these are fields for "I/O,L/R TO STK", "IN: 69.861 ft", "RIGHT: 47.923 ft", and "FILL: 6.015 ft". At the bottom of the diagram area are "BS/SET" and "CONFIG" buttons, and a dropdown menu showing "AR: 3°00'00" ZA: 90°00'00" SD: 50.0000ft".

Below the diagram area is a table with columns for Northing, Easting, and Elevation. The table contains data for "Staked" and "Design" points. Below the table are fields for "Move: In 69.86 ft Right 47.923 ft Fill 6.015 ft", "VOff 1", "Elev:", "VOff 2", "Elev:", "ZA: 90°00'00" AR: 3°00'00" SD: 50.0000", a "Store Point" checkbox, "Point ID: 1042", and a "Point Description" field containing "STK398 Ave CUT 1.398".

At the bottom right is a list of descriptions. The "Desc:" field contains "eBOX". The list includes: DECK, DEFAULT, DH, DITCH, DL, DMH, DR, DRV, and EBOX (highlighted in blue). To the right of the list are several icons for editing and deleting items.

Click the one you want and then press Enter on the keyboard to return to Stakeout.





## 6.11 Stake Line / Arc

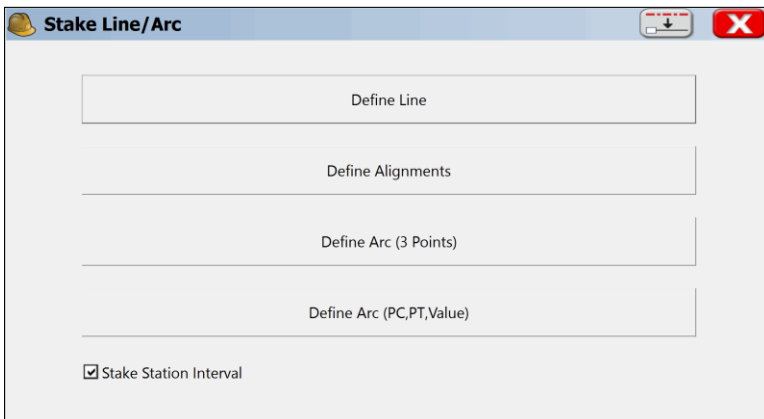

This command opens a secondary dialog where you can choose between Define Line (single line, no curves), Define Alignments, Define Arc (3 points), and Define Arc (PC, PT, Value). If within the Configure option, "Prompt for Total Station Setup" is clicked on for total station work, the Stake Line/Arc command will go first to the backsight screen. When taking the backsight, note that with Leica "ATR", or Sokkia "Search on Read" or Topcon "Auto Aim" clicked on, you can be sighting your backsight slightly off the prism, and the instrument will read and lock to the crosshairs. This can save time on dialing in precisely to the center of the crosshairs, both for backsights and for foresights. This can accelerate the work especially when doing repeated stakeout measurements.

**Stake Station Interval:** The Stake Station Interval option, when clicked on, leads to a dialog that includes the station and offset to stake and the interval to increment. It allows the staking of particular locations on an alignment. When Stake Station Interval is clicked off, the program reports the station and offset of measured points and for your current position (GPS and robotic total stations), and does not prompt for a target station, offset and interval. It leads to fewer screens and does not include the "Point on Line" and "Point on Arc" options, which appear specifically in the Stake Station Interval dialogs.



**Reference Centerline:**  The middle icon on the top line leads to global settings that allow a master centerline (horizontal alignment) to be designated for reference, while you stake out a separate alignment for L and R instructions. For example, if you are staking a curb or right-of-way, you could designate the main road centerline as the "master centerline" and the curb or right-of-way alignment as the target alignment for stakeout. If you "Use Reference CL for Station and Offset", then you obtain reports of



the station and offset of your position relative to the master (reference) centerline. Other options include referencing only the station or only the offset of the master centerline. And if you click on "Use Reference CL to Display Directions", then your instructions to move in the field lead you to the target alignment but reference the master centerline. In the screens below, you select the name of the master centerline. You can also designate whether curves are based on "railroad" definition or standard road definition. Note that even the appearance of this option is controlled by Job Settings, Stake Tab, Alignment Settings, option "Allow Reference Centerline". If off, the Reference Centerline icon itself does not appear.

The image shows two overlapping dialog boxes from a software application. The top dialog is titled "Settings" and has a "Road" tab selected under the "Alignment" section. It contains several checkboxes: "Combine Station Equations" (unchecked), "Apply Station Equations" (checked), "Offset Gap Type: Fillet" (checked), "Allow Reference Centerline" (checked), "Remove Sta Eq when Loading SCT file" (unchecked), and "Remove Sta Eq when Loading PRO file" (unchecked). Below these is a "Limit Sta. Range:" section with input fields for "0+00.000" and "3+08.327" followed by "ft". There is also a "Use Station and Offset List" checkbox and a "File:" label. Two buttons, "Select File" and "Edit File", are on the right. The bottom dialog is titled "Reference Centerline" and shows a "Centerline" dropdown menu with "C:\Carlson Projects\Data\DEMO.cl" selected. Below this, it says "Centerline: 0+00.000 to 3+08.327". It has checkboxes for "RR" (unchecked), "Use Reference Centerline" (checked), "Use Reference CL to Display Current:" (checked, with a dropdown menu showing "Station and Offset"), "Apply Values to Auto Description" (unchecked), and "Use Reference CL to Display Directions (Stakeout Only)" (checked).

## Define Line

This command allows you to stakeout to a line between two points by guiding you to the point with a series of commands and directions. It is also specifically the option to use for staking a "Point-On-Line" such as when marking a property line. A Reference Alignment can also be used (see discussion of Reference Alignment within the Define Alignments option below).

This option is for setting out points along a line including the cut or fill, or for staking out points relative to the line. One application, for example, would be staking a pipe between two known points (inlet and outlet), where offset stakes can be set with cut/fill noted. Station Store might even be used to calculate, in advance, the inlet and outlet points based on a known station, offset and elevation. For all staking, there are configuration settings that govern the type of instructions you receive in stakeout. You



should review the settings in the **Stake** tab under **Job Settings**, as well as the **Configure** option within **Equip** before staking. The dialogs are varied slightly with respect to total station or GPS equipment. Both types are documented here, illustrating the differences between the dialogs.

Stakeout by Define Line also has a **Point On Line** tab that enables, in total station mode, staking of the intersect with the specified line on the current line-of-sight. This is often used to set stakes or flagging along a property line by sighting gaps in tree lines. The surveyor finds a gap in the line, takes a reading to the prism and is advised how far to Move In or Move Out to stake the line at the current line-of-sight. The Point on Line tab also includes the standard perpendicular method, where any measurement is used to compute the direction and distance to move to go to the point on the line perpendicular to the measured point. For GPS configurations, Point On Line offers only the Perpendicular method.

First Point ID: (from Current Job)	3	[List]	[Map]
Second Point ID:	14	[List]	[Map]
North Azimuth:	98°22'00"	Use Points	
Slope:	0.00%		
Method	<input checked="" type="radio"/> 2 Point <input type="radio"/> Azimuth		
Start Sta:	0+00.000		
End:	84300+28.923	Confirm NEZ	

The Define Line dialog gives you the following options:

- **First Point ID:** This is the starting point of the line. You can enter the point here by point ID. The first button brings up the list points dialog where you can select the starting point of the line from a list. The button directly to the right allows you to choose your point from the map instead. If you pick a point from the map in a crowded area of points, you will be directed to the list points dialog to select the desired point among those near to your chosen position.
- **Second Point ID:** Pressing Enter from the first point moves the cursor to the second point. This is the ending point on the line that is only available for entry if Method is set as Two Point for defining the line. The procedure for selecting this point is the same as for the first point.
- **Azimuth:** This option will be available for input only if Method is set to Azimuth. If Method is set to Two Point, then the Azimuth is inactive, but still displays the azimuth or bearing between the two points of the line. The Azimuth method will prompt for bearing if Angle Type is set to bearing in the Format section of Job Settings.



- **Slope (%):** Just like the Azimuth, this option will be available for input only if Method is set to Azimuth. If Method is set to Two Point, then the slope is inactive, but still displays the slope between the two points of the line.
- **Method:** This option lets you choose how to define your line. The available options are by two points, or one point and an azimuth and slope.
- **Start Station:** This option defaults to 0 within Stakeout Line, but can be changed to any starting station.
- **Confirm NEZ:** Selecting this button brings up the Confirm NEZ dialog box. This screen displays each point as a tab at the top of the screen. Listed is the point number, Northing, Easting, Elevation and Description of the point(s) selected for the line. After you confirm the points, selecting the back arrow will take you back to the line definition screen. Pressing Enter after Confirm NEZ automatically continues to the next screen.

If "Stake Station Interval" is off in the opening dialog to Stake Line/Arc, then you would go directly to the measurement screen as shown below. If using GPS or robotic total stations, your current station and offset is shown immediately, real-time.

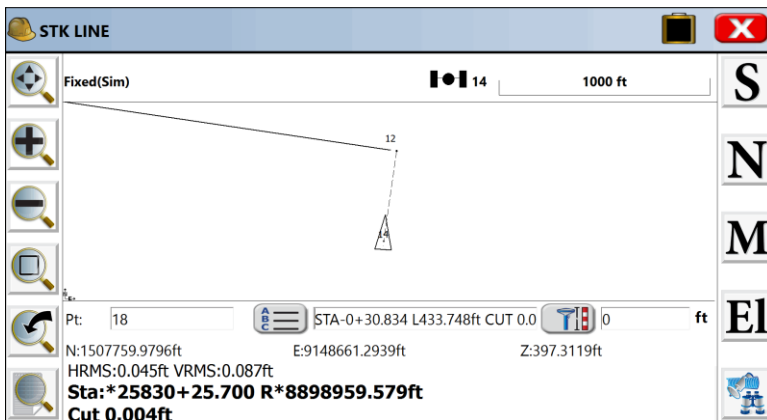

Figure 4: Stake Station Interval Off

For standard total stations, a measurement must be taken (Enter key or R for Read) to see the Station, Offset and Cut or Fill. Dashed lines are drawn from the instrument to the backsight, to the current point being measured, and perpendicular to the defined line. The icons on the top line indicate battery status, prisms being used, the instrument status on the target prism, and tracking readings occurring (so the position of the prism can be computed - the triangle). If you choose "Stake Station Interval" (set in opening screen) when using Stake Line, then you will be prompted for the station to stake, as shown below:

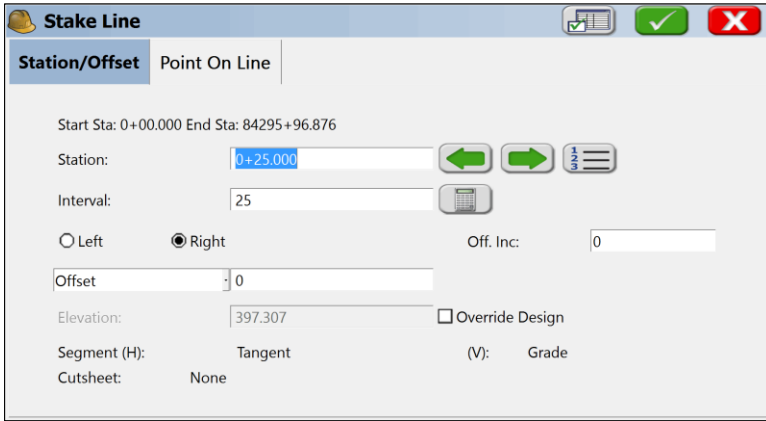

Figure 5: Stake Station Interval On

Clicking OK (green checkmark) proceeds to the stakeout screen. The settings button on the top of the screen, left of the green checkmark, will let you stakeout the precise end of the alignment (in addition to even stations), extend the alignment and do many other special features such as load a list of targeted stations and offsets to stakeout along the alignment. In the graphic stakeout screen, you will be advised to move to the target point based on the Viewpoint settings under Equipment, Configure, View tab. It is recommended to click on "Use CL for Reference Object (when applicable)" when the horizontal alignment is clearly visible or known in the field. Otherwise, you could use the instrument as reference for total station work, moving in or left and right as you face the instrument. Here, the reference is the alignment itself, and you are advised to move out towards the alignment and Forward along the alignment.

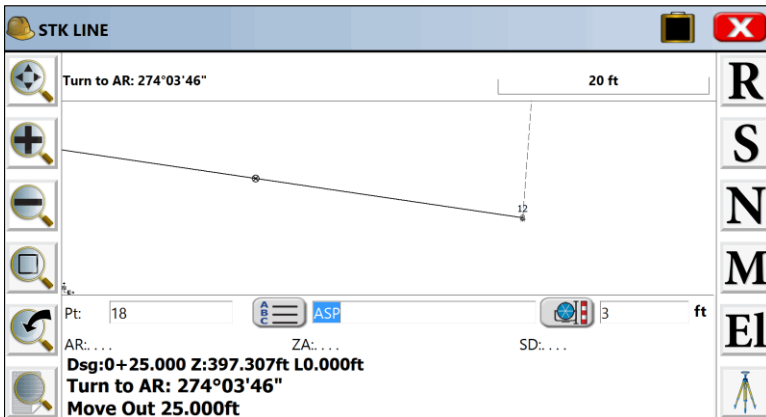

Figure 6: Stake Station Interval On





## Define Alignments (Horizontal)

Stakeout Centerline only requires a horizontal alignment, but you have the option to specify a vertical alignment which will lead to cut and fill results as well. Additionally, you can specify a reference alignment. This feature allows you to stake the offset off of one alignment (e.g. curb) and report the station of a reference alignment (e.g. centerline).

**Define Alignments** [✓] [✗]

**Horizontal** | Vertical

1 Centerline File

2 Select Polyline      4 Preview      5 Edit

3 Define Point List      6 Save As

Centerline: C:\Carlson Projects\Data\DEMO.cl

Start Station: 0+00.000 ft

Ending Station: 3+08.327ft

Cutsheet: None

- **Centerline File:** Select a centerline file defined in the Roads Menu or uploaded and converted to “.cl” format.
- **Select Polyline:** Select a polyline on the screen to define the alignment.

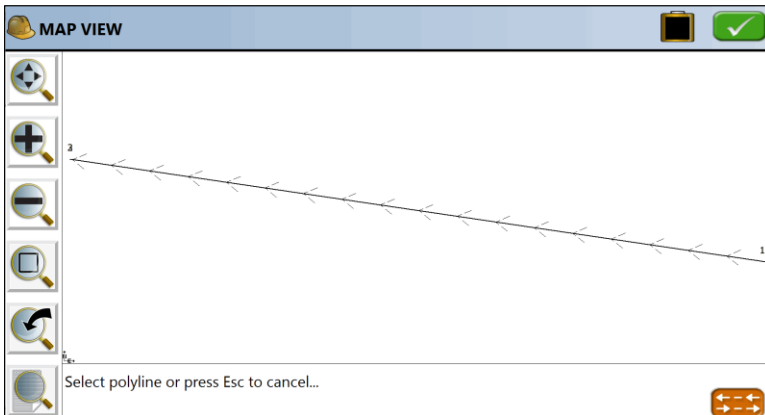

 **Reverse Alignment Direction:** After selection of a polyline, you can use the "Reverse" icon to reverse the direction of the alignment, ensuring that it increments the stationing in the desired direction. This feature is found throughout the software where horizontal alignments are selected from the screen. In the case of File-based or Point-based alignments, the direction is defined by the file or point order itself. This option is



available within Stake Offset, Point Projection, Station Store, Store Sections, Stake Slope and Stake Road.

- **Define Point List:** Enter a sequence of points to define the alignment.
- **Preview:** Displays the alignment graphically, highlighted as a bold line.
- **Edit:** Use this to edit the selected alignment.
- **Save As:** If an alignment was defined by points or a polyline, you can optionally save it as a centerline file.
- **Start Station:** Enter the starting station unless it was pre-determined by a centerline file.
- **End Station:** This shows the ending station of the selected alignment.

### Defining Alignment (Vertical)

This is optional in this command. If your goal is to ignore elevations and you are auto-recalling roading files, the Vertical Alignment will be used and cut/fill will appear unless you turn off Apply Vertical Alignment.

**Define Alignments**

Horizontal **Vertical**

1 Profile File

2 Select Polyline

3 Define Point List

5 Preview

6 Edit

7 Save As

Profile: C:\Carlson Projects\Data\DEMO.pro

Start Station: 0+00.000 ft

Ending Station: 3+08.000ft

Apply Vertical Alignment

- **Profile File:** Select a profile file defined in the Roads Menu or uploaded and converted to “.pro” format.
- **Select Polyline:** Select a 3D polyline on the screen to define the profile.
- **Define Point List:** Enter a sequence of points that have elevations to define the profile.
- **Preview:** Displays the profile graphically.
- **Edit:** Use this to quickly edit the selected profile.
- **Save As:** If the profile was defined by points or a polyline, you can optionally save it as a profile file.
- **Start Station:** Enter the starting station unless it was pre-determined by a profile file.
- **End Station:** This shows the ending station of the selected alignment.
- **Apply Vertical Alignment:** Toggles on/off the vertical alignment for 2D or 3D staking.



Note: For file names to be recalled, *Recall Job Road Files* needs to be enabled within *Job Settings, Options*.

Shown below is an example of what will you see when you tap **Preview** in either tab. Notice that the centerline is shown, along with any existing point numbers in the vicinity.

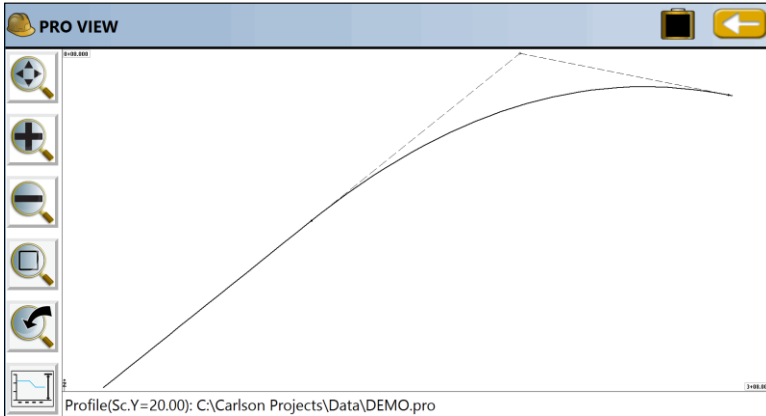

With Stake Station Interval On, the alignment selection screen continues into the Station/Offset screen where you select your station and offset to stake out. Using Define Alignments, the Point on Line option becomes Point on CL in the screen that follows. With both horizontal and vertical alignments defined, the final stakeout screen (e.g. station 375) includes cut and fill values. Shown below is an example in GPS mode. The centerline was picked from the screen (Select Polyline) and the vertical alignment was selected from a file.

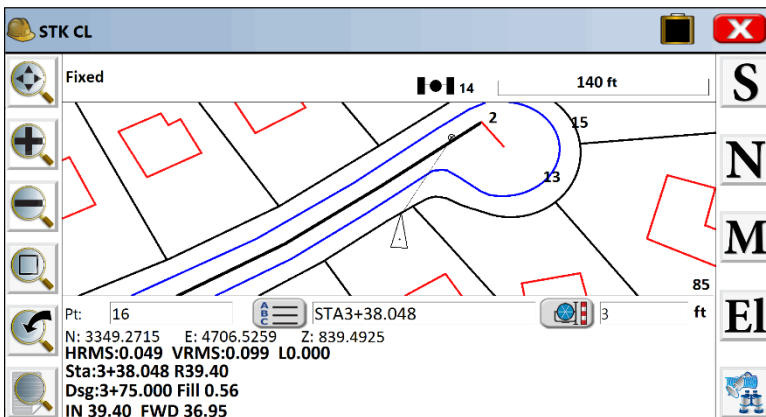

Figure 7: Stake Station Interval On



### Reference Centerline Example

If a Master Centerline or "Reference Alignment" is used and Stake Station Interval is Off, and "Use Reference Centerline to Display Station and Offset" is on, you will obtain the cut/fill from the target alignment. Note the Station and Offset, shown with the "\*" symbol, from the Reference Centerline:

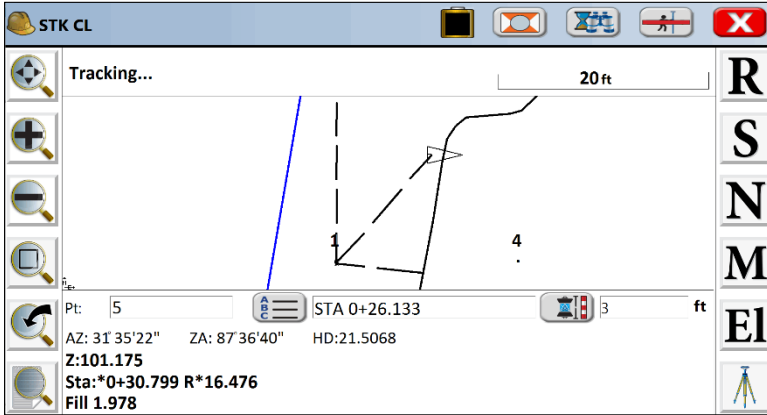

Figure 8: Stake Station Interval Off

However, with Stake Station Interval On, and in addition, "Use Reference CL to Display Directions" on, the same position shown above is displayed with both current position and instructions to move provided in relation to the Reference Alignment.

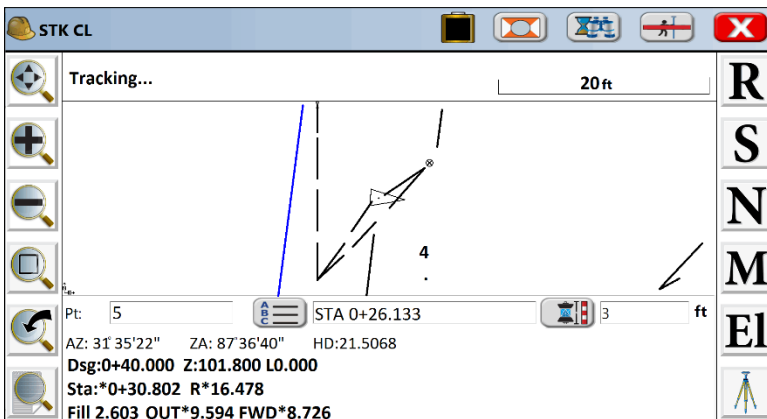

Figure 9: Stake Station Interval On

The example above illustrates a common use of the Reference Centerline. The bold (blue with color screens) reference centerline may be easier to follow than a curving target alignment such as a curb line. Therefore, the forward and in-out instructions referencing the master centerline may be more useful in moving quickly to the target



point. Any display with an "\*" designation is in regard to the Reference Centerline. The reason for the difference in fill is that with Stake Station Interval On, the target elevation (101.80) is computed at the target station to stake, whereas with Stake Station Interval Off, the target elevation is computed at the current offset on the target centerline (station 0+26.1, which is the default station in the description field). The Reference Centerline station is 0+30.8).

### Define Arc (3 Points)

This routine will request three points to define a unique arc, which is then used for stakeout by station and offset. The first point becomes the beginning of the arc. The prompting is shown below.

Define Arc (3 Points)		OK	Cancel
First Point:	2	[List]	[Map]
Second Point:	4	[List]	[Map]
Third Point:	5	[List]	[Map]
Start Sta:	0+00.000	ft	End:
		<input type="checkbox"/> RR	

The points can be entered in, chosen from the list points button, or selected from the map. After selecting the three points, choose **OK** (green checkmark) to go to the Stakeout Arc dialog. The special stations are limited to PC (start) and PT (end). After choosing a station and offset to stake and selecting **OK**, the main stakeout window appears in map view. In total station mode, an angle to turn to and a distance to go will be displayed at the bottom of the screen. Taking a reading to the current target position will update the display with a new out/in distance and a right/left distance depending upon your job settings. You should see your points and centerline or curve in the map with an icon of the point you need to stakeout to (the circle with the X inside). When using GPS, after selecting **OK** to the Stakeout Arc dialog, you will be placed in the Map screen at your current position with directional instructions to the target point continually updating. You can click "RR" to stake out a 3-point arc by railroad definition. Cuts and fills are computed from the elevations of the points which determine the 3D profile of the arc, and the profile will trend to zero if any of the points have zero elevation. If points are picked using the "snaps", such as when picking the end of a line, a new point ID will be assigned to the picked point. If this point ID has zero elevation, the profile will trend to zero and will impact cut/fill reports. Points can be assigned elevations using Edit Points. The Reference Centerline and Stake Station Interval options as discussed above apply also to all methods of Define Arc. The Point on Arc option only appears if Stake Station Interval is On, since this option appear in the interval dialog.



## Define Arc (PC, PT, Value)

This option for defining the arc requires four input parameters: Start point, End Point, Curve Direction, and any of the following: Radius Point, Radius Length, Arc Length, Delta Angle or Degree of Curvature. The starting station defaults to 0, but can also be changed. See the figure below.

**Define Arc (PC,PT,Value)**

Direction:  
 Curve Left  Curve Right  RR

Start Point: 15 [List] [Map]

Radius Point: 2 [List] [Map]

End Point: 13 [List] [Map]

Start Sta: 0+00.000 ft End: 1+79.592



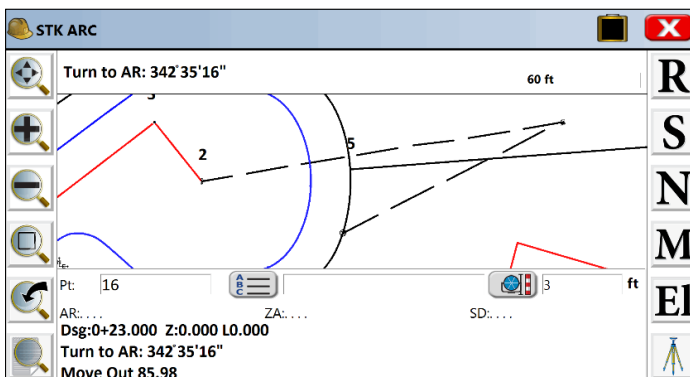

When selecting the PC point, option Radius Point and PT point, enter the point ID, choose the point from the list points screen button, or pick the point from the Map button. When you pick using the Map button, you can pick the point numbers or use one of the "snaps" at the bottom of the screen, like "endpoint snap" and pick a line element. In this case, a new point ID will be assigned to the picked point. After selecting **OK** you will be directed to the Stakeout Arc dialog. After selecting **OK** to the **Stakeout Arc** dialog, the main stakeout window appears in map view. Here we are staking station 75 at 0 offset. In total station mode, an angle to turn to and a distance to go will be displayed at the bottom of the screen. Taking a reading to the current target position will update the display with a new out/in distance and a right/left distance depending upon your reference settings in **Configure Reading**. You should see your points and arc in the map with an icon of the point you need to stakeout to (the circle with the X inside). When using GPS, after selecting **OK** to the **Stakeout Arc** dialog, you will be placed in the **Map** screen at your current position with continuously updating instructions to the stakeout point.





## Stake Line/Arc (Station/Offset)

When Stake Station Interval is clicked on, then selecting OK on the Define Line, Define Alignments or Define Arc dialogs presents the Stake Line dialog for defining the stake location parameters (e.g. station, offset, interval and even elevation).

- **Station:** This is where you enter the station to stakeout.
-  **Station +:** You can advance to the next station as defined by the alignment points or station interval using the right green arrow icon.
-  **Station -:** You can go back to the previous station as defined by the alignment points or station interval using the left green arrow icon.
-  **Station List:** Select a specific station using the station list icon.
- **Interval:** This is where you choose the distance by which to increment the stations.
-  **Calculate Interval:** This is used to divide the entire line into equal parts, which results in a calculated, non-rounded, incremental station.
- **Offset/Skew List:** This is where you enter in the offset distance from the line. Select one of the left/right radio buttons to determine the offset side. This list also provides additional methods of offsetting, such as Skewed Offsets, Bisectors, Intersections and PI or Radius Points. A Skew Forward angle is measured forward from the perpendicular, and a Skew Back angle is measured back from the perpendicular. So looking forward down a tangent centerline, a pipe with a skew of 70 degrees (in DD.MMSS) from the forward tangent would be a Forward Skew Angle of 20 degrees, as measured forward from the perpendicular (normal) offset.
- **Elevation:** This is the design elevation. If the defined geometry is 2D, then this option will be active.
- **Override Design:** This allows the user to override the design elevation of 3D geometry.
- **Off. Inc:** This is for entering an optional incremental offset along the line. This is a rarely used feature that would trend the offsets away or in to the centerline.



- **Segment:** This defines the current segment of the alignment based on the entered station.
- **Cutsheet:** This shows the currently selected Alignment Cutsheet file.
-  **Settings:** This icon takes you to the Job Settings that apply to alignment staking. See Job Settings (Stake) for more details. Note that this is where you instruct the software to include and stop at critical alignment locations.

### Stake Line/Arc (Point On Line)

The Point On Line option appears when Define Line or Define Alignments is selected with Stake Station Interval clicked on. The options appear in the Stake Line (Interval) dialog. It offers a Perpendicular to Line method for total stations and GPS. This method projects any shot onto the alignment perpendicular or radial in curves, and prompts for the distance and direction to move to the alignment intersect point. However, only if you select Define Line as the method to define the alignment and you are set to total stations, is there a "Find Intersect to Line" option, which enables "line-of-sight" staking of lines. This is often used by surveyors who are setting line in tree lines, moving to gaps in the trees for readings, then moving in-out along the line-of-sight and driving stakes when perfectly on line. It is useful for any line or boundary staking, such as property lines, right-of-ways and construction lines. For GPS, only the Perpendicular method is available.

**Total Stations:** The **Offset to Line** option is grayed out when the **Find Intersect to Line** method is selected and available only when the Perpendicular option is chosen.

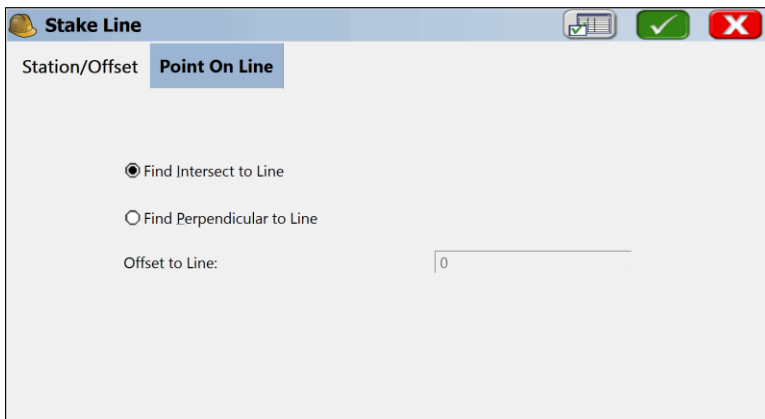





**Total Stations, Define Line, Point On Line, Intersect to Line:** The Intersect Method is used to set line by moving in or out at the current line of sight. A major application is setting line where the line is largely blocked by trees or obstructions, and you must set the line in gaps where you do have a line of sight.

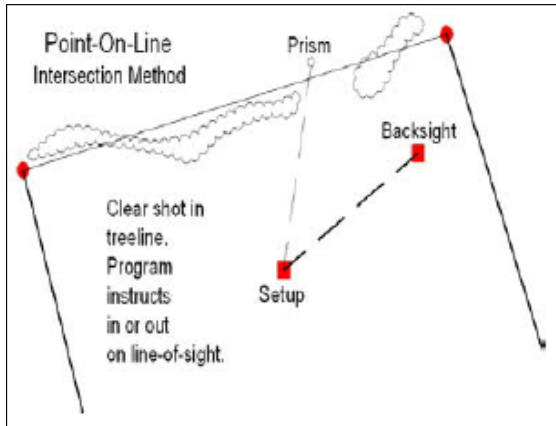

In the Intersect mode, the first screen always displays the target point on the line (or the extension of the line), perpendicular to the setup or station point. When the first reading is taken, the program will display the In-Out distance to the line along the line-of-sight. Regardless of the Reference Centerline settings, the instructions will be In-Out to the target line. However, if Reference Centerline is active, the station and offset to the reference centerline will be shown, with an "\*" prefix.

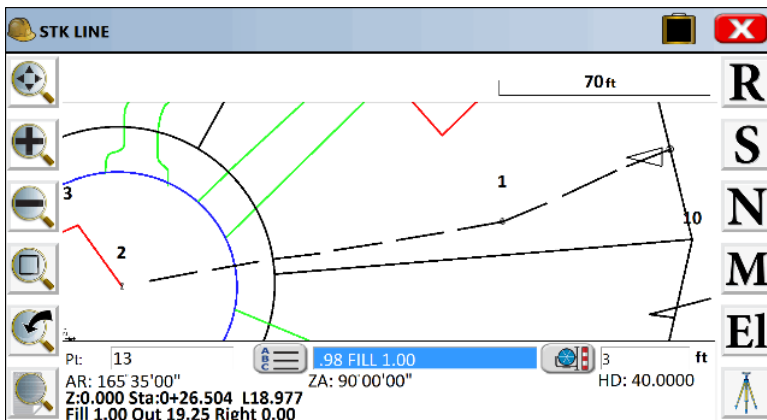



When staking a line defined by points with zero elevation, the cut or fill values will be displayed but should be ignored. Notice that the screen expands to show more graphics by pressing the down - arrow key.

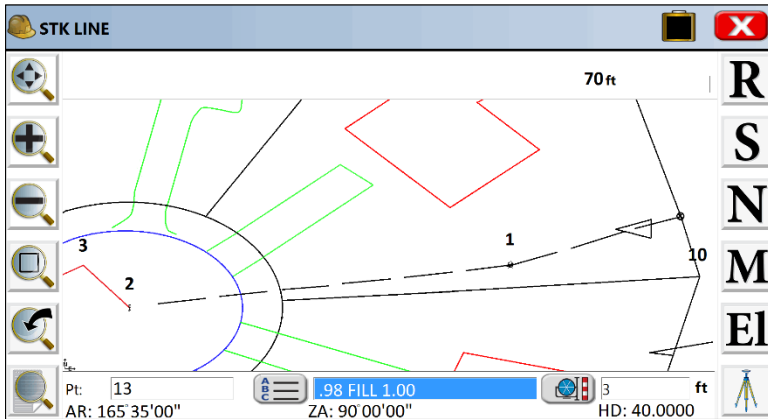

**Total Stations/GPS, Perpendicular to Line:** When configured for the Perpendicular to Line method, the program will show the direction and distance to move to find the nearest point on the line to the measured point. The instruction received (In/Out versus North/South or Azimuth/Distance) will depend on the setting within Configure Reading.

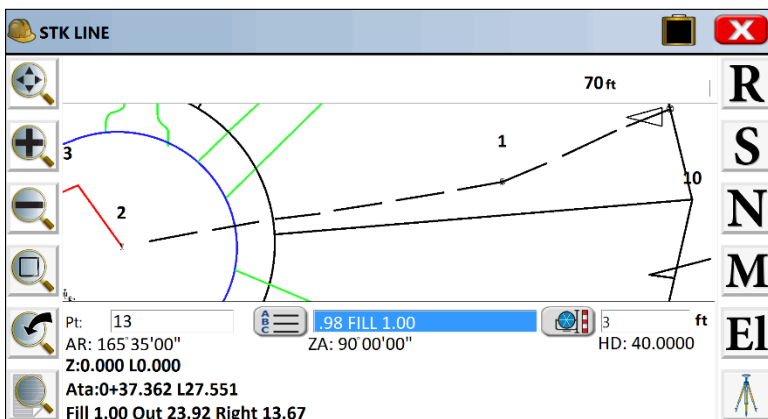

The “Turn to AR” advice at the top of the screen refers to the angle to turn to intersect the defined line at 90 degrees from the instrument location. For GPS, the Point-On-Line screen instructions are similar.

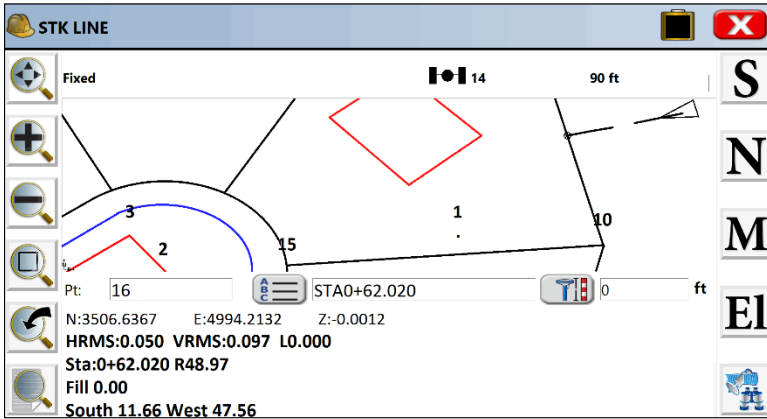

### Stake Line/Arc (Point on Arc)

Both the Stake Arc (3 Points) and the Stake Arc (PC, PT, Value) routines have a Point On Arc option similar to the Point On Line option. This appears if Stake Station Interval is clicked on in the opening screen of staking options. In the dialog below, we have chosen to calculate a left 25 offset from the arc. Any measured point will then be translated radially onto the arc that is 25 units left of the specified arc.

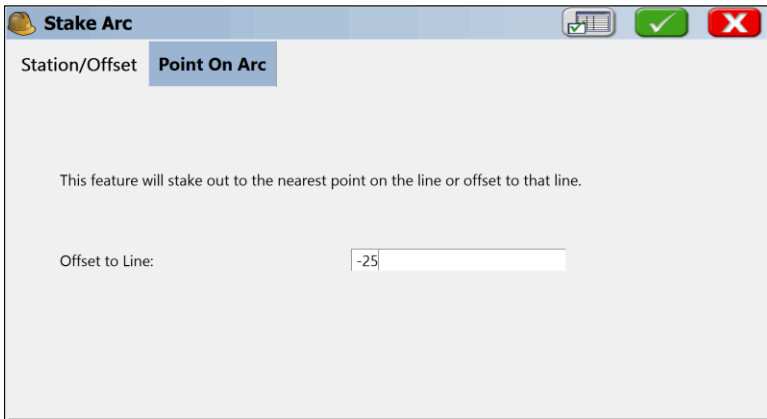



When a measurement or GPS reading is taken, the target point will be radial to the curve, at 25 units offset from the curve, as shown below.

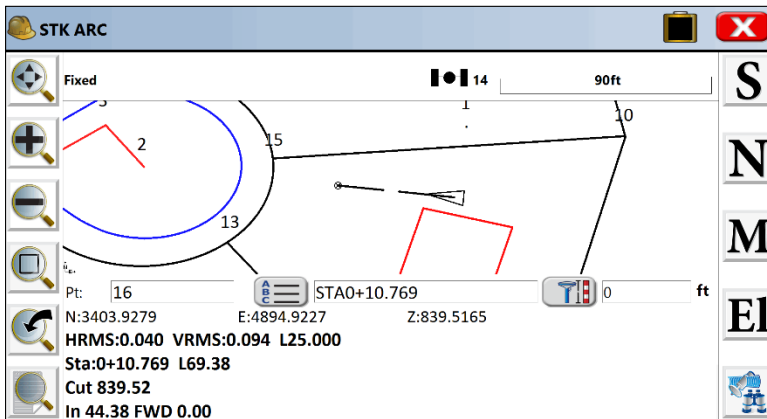

The above example might be useful for setting stakes at a 25' building setback from the right-of-way line. For GPS, information is provided "real-time". As you move, you see the instructions to contact the nearest point on the arc (or offset to the arc). For total stations, you are first instructed to measure to the nearest point on the arc (or arc offset) from the instrument setup. Then after you take any shot, the instruction refers to that measurement.

*Note: The Turn to AR advice refers to the angle to turn to contact the centerline at 90 degrees (right angles) to the instrument setup.*

After selecting **OK**, the main stakeout window appears in map view. In total station mode, it will be waiting for a shot or reading. You should see your points in the map with an icon showing the location of your target (the circle with the X inside).

*Note: If the points defining the line are at zero elevation, the program will still report a cut and fill -- in this case a cut from the GPS elevation of 839.52 all the way to zero. If the points defining the line are at a known elevation, the elevation will be interpolated to determine the design and target elevation of the point to stake and will be applied to a zero offset or non-zero offset stakeout position.*

**All Stake Line/Arc Options:** Store a reading and the coordinates for the Stake Point and the Target Point are displayed. Store by pressing Enter or S to Store. The delta North, East and the elevation difference (Cut/Fill) are also displayed. The **Vert Offset 1** and **Vert Offset 2** allow for elevation calculations based on the input vertical offset values. In English units, a vertical offset of -10" can be entered for example in that form, and the program will auto-calculate -0.833 as the offset. If Vertical Offsets are detected, and a point is stored, you are prompted for additional descriptions for the vertical offsets. If "Alignment Cutsheet" storage is on (as set in Job Settings, Stake tab), an additional cutsheet "row" will be created for each vertical offset. Shown below is a stakeout of station 125, Right 12, and the resulting Report screen.



The screenshot displays the STK CL software interface. The top window shows a map with a blue alignment line and a black design line. The map includes a scale bar for 40 feet and a point labeled '14'. Below the map, the following data is shown:

Pt: 16  
N:3274.4460 E:4517.6257 Z:839.5112  
HRMS:0.043ft VRMS:0.091ft R12.000  
Sta:1+43.085 R12.12  
Dsg:1+25.000 Cut 0.078  
IN 0.12 Back 18.09

The bottom window is titled "Stakeout Report" and includes a "Ref CL" checkbox (checked) and a green checkmark icon. It has two radio buttons: "Show North/East" (selected) and "Show Station/Offset".

	Northing(ft)	Easting(ft)	Elevation(ft)
Staked:	3268.242	4500.291	839.487
Design:	3268.222	4500.298	838.735
Move:	South: 0.02ft	East: 0.01ft	Cut 0.075ft

Below the table are input fields for "VOff 1:" and "VOff 2:" (both in ft), and "Elev:" (both in ft). Other fields include HRMS:0.046ft, VRMS:0.107ft, and PDOP:3.200. There is a checked "Store Point" checkbox and a "Point ID:" field with the value "16". At the bottom, there is a "Set GIS" checkbox and a text field containing "STA1+25.000 R11.98 CUT 0.75ft".

Note that you have the option to store a point in stakeout. If the point being stored is the same as one in the current job file, the **Point Protect** dialog box appears stating that the point you chose has already been used. The next available point number is listed with the option to overwrite the current point or use the new number. If you "Show Station/Offset", you will see the Station and Offset of the design (1+25.000 R12.000) and staked point (1+25.000 R11.979), for example.

Cut and fill data, including vertical offsets, will be stored in the Alignment Cutsheet File if named and turned on within **Job Settings, Stake tab, Cutsheets**. Finally, the data is always stored to the raw (.rw5) file as cut/fill (cutsheet) information. If you forgot to create a cutsheet file, you can make a new one, and when formatting the cutsheet, select "Cutsheets from Raw" as one of the options. You can review the cutsheet using the Helmet, View Data option. You can also review the cutsheet with the shortcut, Alt V, from the active stakeout screen. Both will return you directly to stakeout. If using GPS, the HRMS, VRMS, and PDOP values are also displayed, as are Fields for Point ID and point description input. After the point has been stored, you are taken back to the Station/Offset dialog to select the next point for staking.

When you return to the Stakeout Line screen after storing a point, there is a tab option for **Next Alignment** that allows you to define a new alignment, without exiting the command.



## 6.12 Stake Offset



This command will stake out up to two user-defined horizontal offsets to a centerline at any station, as well as an unlimited number of offsets per station, if you are using a predefined Cutsheet Station and Offset List (loaded using the Settings button). It will also stake out the centerline itself. Station intervals can be entered, and the program will auto-detect, at the user's option, special stations such as the TS, SC, PC, PT, CS, ST and vertical curve points (including high and low points). Because individual stations and offsets can be entered, and also because pre-made station and offset lists can be recalled in the field, Offset Stakeout can be applied to virtually any offset point along a centerline.

### Prerequisites and Procedures

**Stake Offset** requires both a horizontal and vertical alignment. If total stations are involved, **Stake Offset** passes through the normal backsight confirmation screens that Store Points and other forms of Stakeout require.



The Offset Stakeout command is a three-screen routine. The first screen identifies and loads in the alignment files. The second screen identifies the offset points to stake (slopes and distances) and the intervals or lists of stations/offsets to stake. The final screen goes to the standard graphics, shows the target points, and guides you to the destination, with N for Next continuing onto the next station in the interval or list.

### Identifying the Alignments

The first screen has tabs for selecting both the horizontal and vertical alignments. See [Stake Line/Arc](#) for more detail.

Stake Offset	
Horizontal   Vertical	
1 Centerline File	
2 Select Polyline	4 Preview
3 Define Point List	5 Edit
6 Save As	
Centerline:	C:\Carlson Projects\Data\DEMO.cl
Start Station:	0+00.000 ft
Ending Station:	3+08.327ft
Cutsheet:	None



**Stake Offset**   

Horizontal **Vertical**

1 Profile File	5 Preview	6 Edit
2 Select Polyline	7 Save As	
3 Define Point List		

Profile: C:\Carlson Projects\Data\DEMO.pro



Start Station:  ft

Ending Station: 3+08.000ft



### Settings

Use this button in the upper part of the screen to select predefined station lists and critical stopping points along the alignments.

**Job Settings**  

Stake **Alignment** Road

- Increment from Starting Station
- Extend Alignments
- Stake Start and End Stations
- Stake CL Alignment Points
- Stake Profile Points
- Stake High and Low Points

Limit Sta. Range:  
 to  ft

Use Station and Offset List

File:

Within this option, you can click the **Stake** tab and edit your default Stake Offset Descriptions shown below. See [Job Settings \(Stake\)](#) for more details.



### Job Settings

Stake Alignment Road

Precision: 0.000

Store Data to Note File

Merge Ctrl File Pts for Stk

Control Pts Have Priority

Use Automatic Desc

Increment Pt ID:  Up  Down

Stake Offset Desc

Auto Descriptions

Cutsheets

### Default Descriptions

Description	Alias
LCurb	LCurb
LDitch	LDitch
LEOP	LEOP
CL	CL
REOP	REOP
RDitch	RDitch
RCurb	RCurb

Alias: LCurb



Update Item





## Entering the Offset Points as Slopes and Distances

The Offset Stakeout screen allows you to enter one or two offsets from the centerline. The first offset requires a percentage slope and a distance. The second offset is for a curb or ditch and is prompted in the form of “distance over” and “elevation change up or down”.

- **Settings:** The Settings button returns to the Settings dialog, allowing you to load another cutsheet list or specify more or less special stations. Note that in Settings, if you called for a Station and Offset List, then most of the options in the Offset Stakeout dialog are fixed, and your only choice is to stake the particular offsets named in the list. Also, note that Offset Stakeout, when not using a List, allows for the staking of three points on the Left or Right Side: Center, Curb (or Ditch) and EOP. On the left, it becomes LEOP, LCurb or LDitch. On the right, it becomes REOP, RCurb or RDitch. You must enter data for the right as well as the left if you are staking both sides of a road. So there are five points total that can be staked when you use the dialog entry, since the centerline is covered in both the Left and Right scenarios.
- **Back:** The Back button returns to the first screen.
- **Station:** This is where you enter the station you wish to stakeout.
-  **Station +:** You can advance to the next station as defined by the alignment points or station interval using the right green arrow icons.
-  **Station -:** You can go back to the previous station as defined by the alignment points or station interval using the left green arrow icon.



-  **Station List:** Select a specific station using the station list icon.

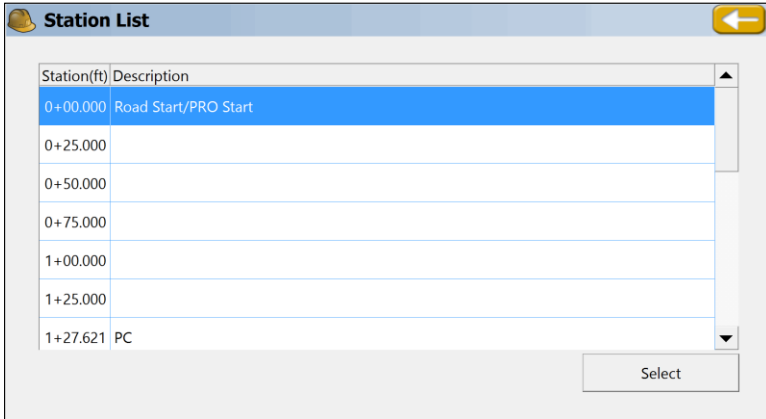

Station(ft)	Description
0+00.000	Road Start/PRO Start
0+25.000	
0+50.000	
0+75.000	
1+00.000	
1+25.000	
1+27.621	PC

- **Interval:** This is where you enter the distance by which the stations should be incremented.
-  **Calculate Interval:** This is used to divide the entire line into equal parts, which results in a calculated, non-rounded, incremental station.
- **Set Stakeout Target:** The button found to the right of the offset entry box will switch from RCurb to REOP to CL and back, and the large solid circle will move and highlight the correct location. These abbreviations are defined in the Settings dialog or the Stakeout tab of **Job Settings**.
- **Left/Right:** You can specify whether to stake the left or right side of the road. The offsets are applied symmetrically. If you have a special case on a specific side of the road, do the right and left separately, with separate slope and distance entries.
- **Offset:** This is the first offset from centerline. Units are as configured in **Job Settings** (feet or meters).
- **X-Slope:** This is the first offset slope. Negative represents downhill.
- **Stake Curb/Ditch:** This will allow the user to input and activate a second offset defined by offset distance and height from the first offset.
- **Stake Curb/Ditch (Height):** This is the vertical difference from the first offset to the second offset. A positive entry is interpreted as a curb and a negative (downhill) entry is interpreted as a ditch.
- **Stake Curb/Ditch (Offset):** This is the distance from the first offset to the second (outer) offset.

When using a Cutsheet Station and Offset list, you must select the **List** button, highlight the offset you wish to use and press **Select**. The routine will stay on this offset as it progresses through the stations until the user selects List again and specifies a new offset.

The Stake Offset command will store to the Alignment Stakes cutsheet file format if the file is named and made active for storing. The data can include station and offsets as formatted.



## 6.13 Elevation Difference



This routine will report a cut/fill in comparison to a design surface at any location within a project. The **Elevation Difference** command will save cutsheet data if cutsheet files are named and made active within **Job Settings, Stake** tab. For any surface where a centerline is defined (Road Design and Section, or Grid/Triangulation/Elevation with centerline defined), the routine will not only report, but optionally store cuts, fills and centerline position data into an alignment-style cutsheet file. With no centerline defined, the Road, Grid and Elevation methods will store cut and fill data into a point-style cutsheet file. Elevation Difference can also be used with a light bar.

### Prerequisites and Procedures

There are five types of data that can be used to define the design surface.

- **Grid File:** You may use a .GRD file that has been created using software packages including Carlson Civil or Carlson Survey. You must transfer this file to the collector via the **File Transfer** routine prior to running this command.
- **Triangulation File:** You may use a .TIN file created within SurvPC using the **Triangulate & Contour** command found in the **Map** screen under **Tools, Surface**. You can also use a .TIN or .FLT file that has been created in Carlson Civil or Carlson Survey office products, in which case you must transfer this file to the collector via the **File Transfer** routine prior to running this command. Note that triangulation files can be imported from LandXML or DXF format using the command **File, DTM Import**, found in the **Map** screen.
- **Elevation:** You may use known elevation that you specify in the **Set Elevation** field.
- **Road Design:** This method requires a Template, Centerline and Profile file at a minimum, and can utilize superelevation and template transition files.
- **Section:** This method requires a Cross - section file and a Centerline file.
- **Select Type of Surface Model:** Specify the type of surface to be used. With the exception of the Elevation method, the 4 other methods allow the option to specify a vertical offset (such as to subgrade) and lead to a follow-up file selection dialog.
- **Set Elevation:** This option is available when the Elevation method is used for defining the surface model. Enter the desired elevation of your surface in this field.



**Elev Difference**

Select Type of Surface Model

Grid  Road Design

Triangulation  Section

Elevation  From Alignments

Set Elevation:  ft

VOff:  ft

Use Horizontal Alignment for Sta-Off  Surface Inspector

Stakeout Pattern  Display Graphic Indicators

Light Bar Settings

- **VOFF (Vertical Offset):** This is used in conjunction with grid, triangulation, roading and section files. It allows the user to vertically offset the surface (as defined in the file) by the amount specified in the box.
- **Use Horizontal Alignment for Station-Offset:** This allows specification of a horizontal alignment file (.cl file) for reporting station and offset of the current location to the reference alignment. With total stations this is reported whenever a shot is taken. Using GPS or robotic total stations, with tracking on, your current position is updated in real time as the rover or prism is moved. This option is available with Grid, Triangulation and Elevation types of surface models. (A centerline is required for Road Design and Section-type surfaces).
- **Stakeout Pattern (GPS Only):** The first prompt asks if you want to use the last stakeout pattern. To make a new pattern, you specify, in effect, the lower left corner (“left side” option) or the lower right corner (“right side” option) of a rectangle, and specify the starting point, direction point. Shown in the figure below is a 10x10 layout at 50’ interval (10 rows and columns are added to the starting point, producing 11x11 grid points). The number of cells in the grid ranges from 1x1 to 20x20, and are laid out in a grid beginning at the starting point going towards the direction point.

**Pattern Settings**

Starting Pt ID:

Northing:  Easting:

Direction Pt ID:

Northing:  Easting:

Grid Interval:  Number of Cells:

Cell Alignment:

Left Side  Right side



The program will then show the grid point nearest to your GPS position.

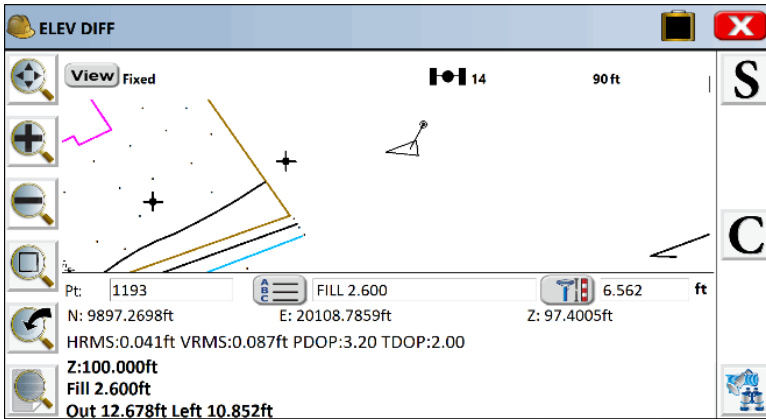

- **Surface Inspector:** This allows the user to inspect a TIN file loaded by clicking on a point on the screen or using snaps (detailed in [Stake Points](#)). When an object is selected, the Surface Inspector appears in the upper portion of the screen. The Surface Inspector will show for the specified point, the elevation of the TIN, Point elevation, and Cut or Fill values. The software has an option “Recall Job DTM Files” and allows the users to select the last TIN and/or Alignment (if checked), speeding up the process. Stakeout and Store routines can be initiated from the Surface Inspector screen.

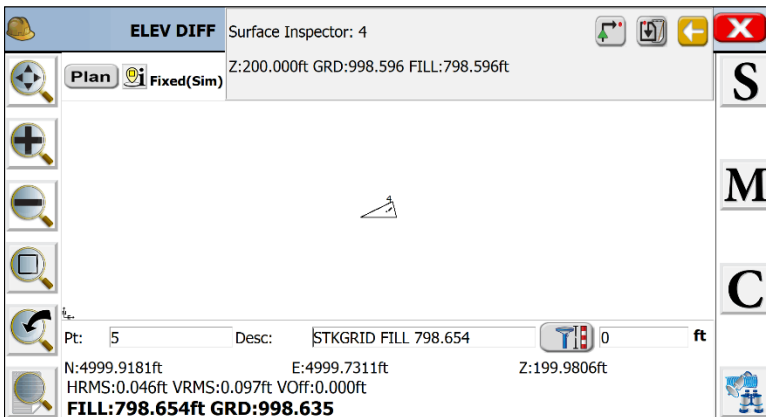

- The data at the top refers to the selected point information.
- The data on the bottom continues to represent the live updating current instrument position.



## Stake using the Surface Inspector

To initiate the Stake Command using the Surface Inspector, click on the Stake Icon . This will present the user with the Elev Diff STK screen.

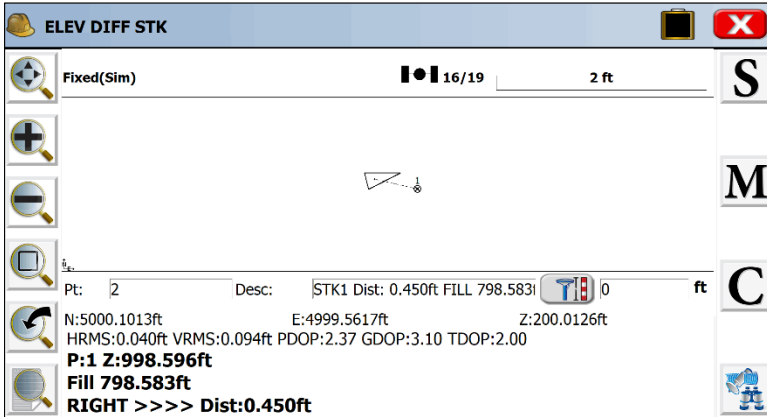

The bullseye will appear when the position becomes closer to the preferred stake out point.

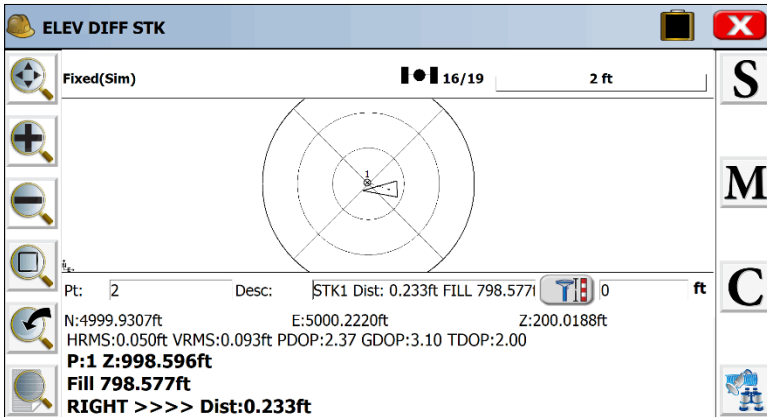

The Stakeout Report will be presented to the user after the point is stored.

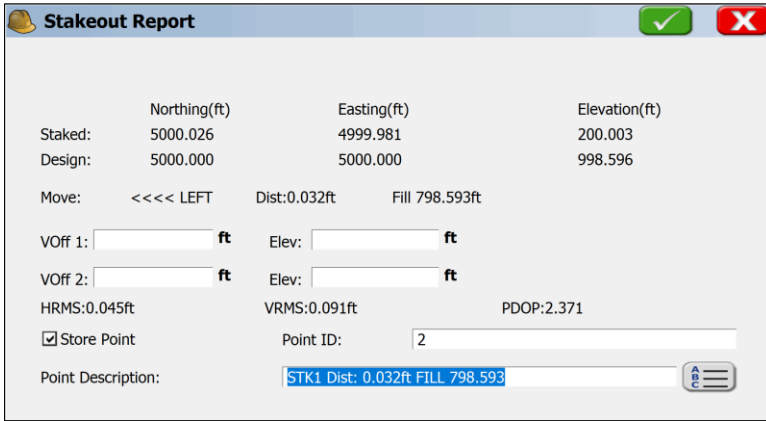

**Stakeout Report** [Green Checkmark] [Red X]

	Northing(ft)	Easting(ft)	Elevation(ft)
Staked:	5000.026	4999.981	200.003
Design:	5000.000	5000.000	998.596

Move: <<<< LEFT    Dist:0.032ft    Fill 798.593ft

VOff 1:  ft    Elev:  ft

VOff 2:  ft    Elev:  ft

HRMS:0.045ft    VRMS:0.091ft    PDOP:2.371

Store Point    Point ID:

Point Description:  [ABC]

Repeat the process for another point to stake if preferred.

### Store Points using the Surface Inspector

To initiate the Store Command using the Surface Inspector, click on the Store Icon  . This will present the user with the Store Inspected Point screen.

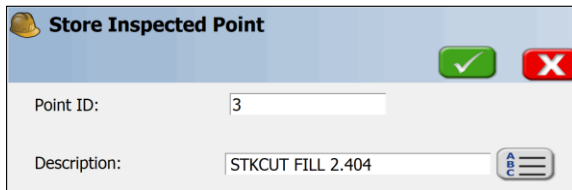

**Store Inspected Point** [Green Checkmark] [Red X]

Point ID:

Description:  [ABC]

To stop press the M or modify Icon. Press the orange arrow to exit.

- **Light Bar Settings:** This button allows you to specify parameters for enabling the light bar, setting the grading tolerance, and specifying the COM port. The two light bars currently supported are Mikrofyn and Apache. SurvPC can actually drive the grading process, as shown below, where an Apache light bar is used on a motor grader. In effect, this offers extremely low cost "grade indicate" machine control.



Pressing **OK** from the main **Elevation Difference** dialog will first prompt the user to load the surface files involved (unless elevation method was selected). Then, when **OK** is pressed again, the ELEV DIFF screen in the following figure will appear. This screen provides the user with a plan view of the project. When a shot is taken, cut or fill from the current vertical location to the design surface is reported in the lower left portion of the screen. The computed design surface elevation for your current location is also reported.

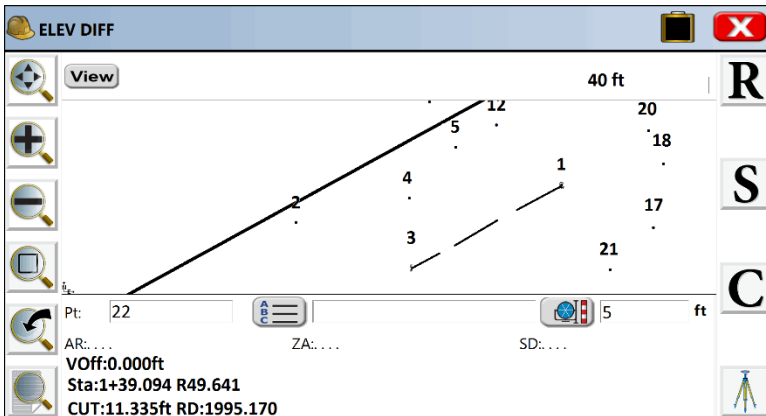





When Road Design Files are selected, there is an extra Settings option at the top of the screen that is used for setting the location of the Profile position on the template.

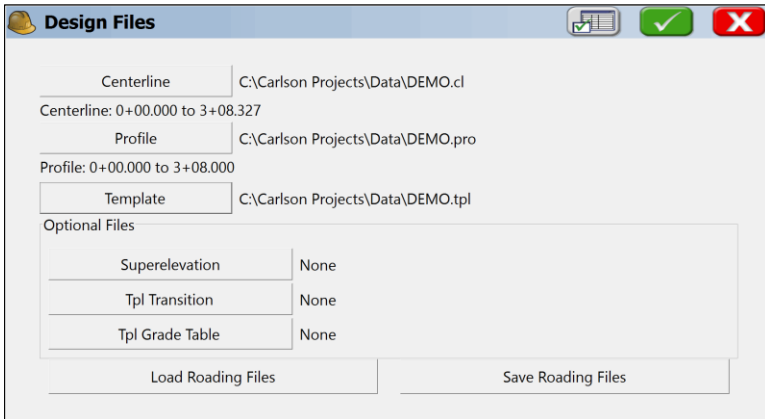

**Design Files**

Centerline: C:\Carlson Projects\Data\DEMO.cl  
Centerline: 0+00.000 to 3+08.327

Profile: C:\Carlson Projects\Data\DEMO.pro  
Profile: 0+00.000 to 3+08.000

Template: C:\Carlson Projects\Data\DEMO.tpl

Optional Files

Superelevation	None
Tpl Transition	None
Tpl Grade Table	None

Load Roding Files      Save Roding Files

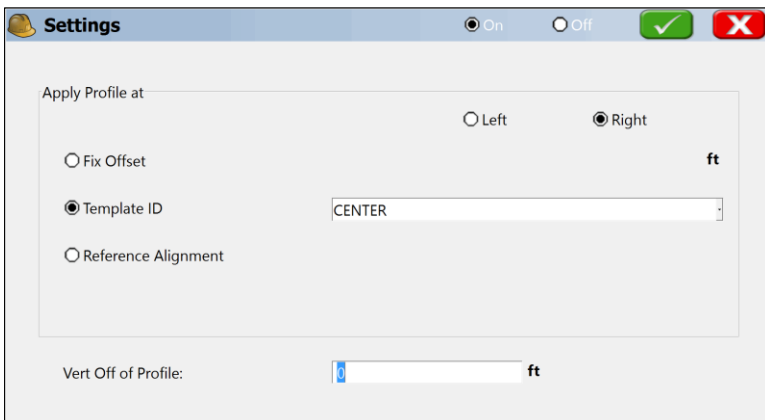

**Settings**       On     Off   

Apply Profile at

Left     Right

Fix Offset    ft

Template ID    CENTER

Reference Alignment

Vert Off of Profile:    ft

In road design, the position of the profile is sometimes placed on an inside edge-of-pavement or at some other offset from centerline, as defined by a fixed offset, a template ID or even a completely distinct reference horizontal alignment. Even when specified, the application of the special profile can be turned off and on. Note that the "Off" status is equivalent to the default condition of profile grade at Template ID "Center". If the Profile positioning is set to "On" in Settings, you will always be prompted with the Settings dialog after loading the Roding files, so that you are reminded of any unusual, active profile offset before continuing by pressing Enter (OK) or changing a setting.



If you click the helmet icon in the upper left of the screen and select **View Data** from the Help options, or enter Alt V, you can select **Cutsheets** and the **Edit File** option to review the stored cut and fill data at any time, assuming a "cutsheet" file has been named and set active. The data might appear as follows:

Staked Sta	Staked Off	Stake Elev	Cut
1+39.09	Right 49.64	2006.51	11.34
1+43.25	Left 23.06	2005.87	10.45
1+29.37	Right 11.39	2007.84	13.26
1+29.73	Right 1.06	2006.55	11.83

◀ [ ] ▶

Insert Up Down Delete Special

The order of the columns in the cutsheet is set by the user when the cutsheet file is named. In this case, the "Use Centerline for Station-Offset" was clicked on, and the shots were stored to the "alignment-based" cutsheet because a centerline was active. All shots were cut, so if you scrolled right to the fill column, it would be blank. Columns can be extended and compressed by moving the vertical bar between columns.

In addition, cut and fill data is also stored to the Raw File associated with the job name. Then when a new cutsheet file is named, you can choose, "Cutsheets from Raw File". For those users who always want a cutsheet file to be made in commands such as Elevation Difference, you can auto-create a new cutsheet with the job name as the prefix, whenever you start a new job, by the following selection within **Job Settings**, **New Job** tab:

**Job Settings** [Green Checkmark] [Red X]

**New Job** System Format Options Stake

Prompt for First Pt

Pt ID: 1

North: 5000 ft

East: 5000 ft

Elev: 100 ft

Desc: Start

Prompt for Units

Use Last Job Localization

Use Last Control File

**Cutsheets:**

Recall Previous

Manual

Recall Previous

Auto-Save By Job

Auto-Save by Job & Date

None

Define Job Attributes



## 6.14 Grid / Face





This command enables points on both vertical and non-vertical planes to be coordinated by angle-only observations. This feature is most often used to pick up details of a building where the prism cannot be placed. You first establish the plane, then take angle-only observations for features such as windows.

The building face is defined by observing three accessible points on the building or by entering their known coordinates. After angle-only observations are made, SurvPC then calculates and stores coordinates of the angle intersection observation with the plane. You can use SurvPC to survey the vertical face of buildings or other vertical planes.

### Vertical Plane Survey

The Define Plane dialog can be accessed by selecting the Grid/Face option from the SURVEY tab of the main menu.

- **Point 1, Point 2, Point 3:** These fields indicate the points that define the building face plane. Both Point 1 and Point 2 must have horizontal coordinates to properly define the building face. For a vertical plane survey, point 3 is not required and can be left blank.
- **Read**  : These three functions allow for three methods to define the coordinates of a point. The coordinates of the points can be manually entered into the Northing, Easting and Elevation fields. Manually entered coordinates will not be stored in the coordinate file.

Existing point IDs can be entered into the Point ID field. These points must be defined by coordinate data. As soon as you enter the point ID, press **enter** and the coordinates will appear in the Northing, Easting, and Elevation fields. Existing points can be



selected from a points list by selecting the **Point List** icon. Highlight the desired point and press enter or tap **OK**.

Existing points can be selected from the map screen by selecting the **map** icon. To select a point, tap it on the screen. If two or more points are close together on the screen, you will be asked to select the intended point from the point list.

Lastly, the points can be taken with the total station by pressing **Read**.

After you have specified the two defining points for the building face plane, SurvPC will determine the available solution. One of the following messages will be displayed in the dialog box.

- **Vertical** - SurvPC has enough data to fix a vertical plane (the vertical example is shown in this above figure).
- **3D** - SurvPC has enough information to fix an arbitrary plane.

Press **OK**, and the following dialog will appear. The building face or vertical plane is drawn as a solid line, and any measurement taken by angle only reading (e.g. angle right of 270, zenith angle of 83 degrees), will plot as a point with calculated x,y,z position, such as point 20.

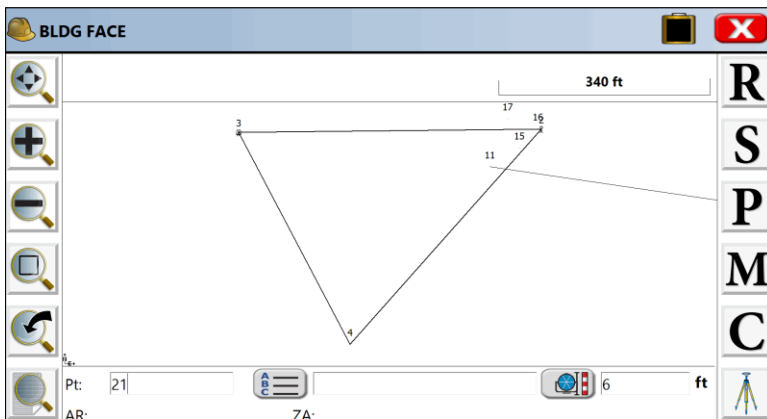

### Non-Vertical Plane Survey

Surveying a non-vertical plane is similar to surveying a vertical plane. Once the plane has been defined, picking up detailed observations follows the same general process detailed above. All three points must be defined for a non-vertical plane survey. When defining a non-vertical plane, the three points cannot be in a line.



## 6.15 Resection



This command allows you to calculate coordinates of an unknown instrument setup point given the angles and distances from up to 20 distinct reference points. The reference points are recalled from your working job file. If a control file is active in **Job Settings**, and the entered point ID is not found in the current working coordinate file, then the point will be recalled from the control file automatically. You can also access points from the control file by using the **from list** icon.

Direct and Reverse measurements can be activated within the **Settings** screen in Resection. The options within Configure expand (e.g. for "Auto Turn" capability) if you are using motorized or robotic total stations versus conventional total stations. If you choose **Direct & Reverse**, then the reverse measurements count as part of the 20 allowable measurements, so the maximum number of reference points becomes 10. As long as you have at least 2 distinct points, you can shoot the same point twice or more with a direct or D&R measurement.

**Configure** [Green Checkmark] [Red X]

General **Sets**

- Backsight (Read D&R)
- Traverse (Read D&R)
- Resection (Read D&R)
- Topography (Read D&R)
- Stakeout (Read D&R)
- Calculate Reciprocals

Set Collection Routine Options

- Review Readings
- Review Sets
- Store Raw Data for Duplicate Points

Set Order:  No. of Sets:

Elevations can be ignored on any measurement. Angle Only Readings can be mixed in as well. This is useful when sighting radio towers and church steeples with known coordinates. In fact, all of your resection points can be measured by angle only, in which case 3 or more points are necessary for an accurate calculation. Sometimes if the 3 angle-only points are in the same quadrant of view, a solution won't be found, requiring additional points. When elevations are used, measurements will contribute to the calculation of the setup point elevation.



After entering the routine, the first screen appears as follows:

Resection [0]

Press Enter or Read to take Reading #1

Point ID: 2

Desc: PT 2  
N: 4281252.3166  
E: 259537.9351  
Z: 97.6071

Status: Standby  
Horizontal: 193°38'22"  
Zenith: 92°41'25"

Inst Hgt: 2 m

Read

Calculate

Ignore Elev

Angle Only

Robotics (Alt+J)

Configure

2 m

The points can also be selected from the point list or directly from the map screen by pressing either the list or map icons. You will also be prompted for the Instrument Height and a Target Height. On reading #1, you will be asked if you want to Set Zero on the first resection point (optional). The user will be shown the status of "Setting to Zero" if selected. If you don't Set Zero, the current azimuth of the instrument will be used. If you click on "Set Azi" then you will not be prompted to Set Zero and when the resection is complete, the known resection points will be used to set the correct azimuth in the instrument. The Robotics and "Status: Locked" displays only appear with motorized and robotic total stations. Reflectorless measurements can be taken in Resection by clicking Prism icon, which switches back and forth from prism to reflectorless. The software supports continuous reflectorless measurements for all capable total stations.



If you press **Configure**, you can set standard errors for the measurements, as shown below. These settings allow you to take advantage of network least squares and weighting in the calculation performed by SurvPC. The default values are shown. You can also enable **Direct & Reverse** measurements here, in addition to using **EQUIP, Configure**.



**Configure Resection**

Distance Standard Errors

Constant: 0.005 m

PPM: 5

Angle Standard Errors

Pointing: 5 s

Reading: 5 s

Setup Standard Errors

Resect Pt ID: 0.005 m

Foresight Pt ID: 0.005 m

Defaults

- Set to Zero
- Set to BS Azimuth
- Set to:
- Use Current
- Set to Zero

Press **Read** when you are ready to take a measurement. The angle right, zenith angle, and slope distance are recorded.

Repeat this process for all measurements of the resection. After the second measurement, there is enough information to conduct the resection calculation, so the **Calculate** button at the top of the dialog becomes active and can be selected. If you select Calculate, you can review the data, then return to taking more shots by hitting back arrow rather than OK, which would prompt to store the point. After selecting Calculate, if you intend to measure to additional resection points, you have the option with robotic and motorized total stations to automatically turn to those points, as shown below:

**Resection**

Press Enter or Read to take Reading #1

Point ID: 2

Desc: Radio1

N: 2734379.4500

E: 808827.4100

Z: 251.0830

Read

Calculate

Ignore Elev

Angle Only

Settings

Configure

Inst Hgt: 5.3 ft

7 ft

If you select Turn To Point, you go to the standard Turn to Point dialog that is used in Stakeout, and you can Search after the Turn and Turn to Vertical (recommended) to be directly on the desired target point. Be sure to set the correct target height for the additional resection points.



Using the Robotics option, you can go to Settings and change the prism constant for distinct measurements. With non-robotic total stations, the Robotics button changes directly to a Settings button, allowing changes as shown below. The prism constant in the FS setting is what is used for all Resection measurements.

Setting	Value
EDM Mode	Standard
FS Target	Reflectorless
BS Target	Leica 360
Guidelights	Off
Guidelights Intensity	Medium
Laser Pointer	Off
Compensator	Enable

Any time Calculate is selected, the Review Resection screen appears. The input data is displayed in a list structure, and you have the ability to turn certain measurements on/off and recalculate the solution, without the necessity of re-measurement. You can also edit point numbers, instrument and rod heights, and more here. When satisfied with your edits and the solution, you can store the results of the resection. Since there is redundant data, the final calculated coordinate differs slightly from the individual measurements. The command reports the calculated coordinate's northing, easting, and elevation, and the difference between the calculated coordinate and the individual solutions as residuals, which indicate the quality of the data. High residuals suggest a problem with the input data. If you select the red X in the Review Resection Screen, you are returned to the Read screen in case you want to collect more shots. Here in the Read screen you can truly Cancel if that is your intention. Shown here is a resection to 2 points using D&R (direct and reverse), with angle only in the reverse face. Note that even in a 2-point resection, a closure calculation is presented. During a 2-point resection, the user has the option to hold the first located point and the azimuth between the two located points by checking the 'Rotate-Only' checkbox. If the 'Rotate-Only' checkbox is unchecked, both located points will be held (normal resection).

Pt ID	XY	Z	On	H Ang	Ang Residual	S Dist	Dist Residual	V Ang	Tgt Hgt
106	ON	ON		00°00'11"		10.0000	0.0008	45°00'00"	2.0000
105	ON	ON		359°00'00"	0°00'8"	10.0000		45°00'00"	2.0000

Inst. Hgt: 5.3

Results:

N: 1266417.007	StDev N: 0.0012
E: 2065201.9556	StDev E: 0.0005
Z: 5505.05	Z RMS: 0.000
Closure: 33208	Ang RMS:(s): 8"
Dist RMS: 0.001	

Rotate Only





In the “**Store this Point?**” dialog box shown below, you are prompted for the point number and description of the calculated point (the occupied station/setup point). With three or more resection points, residuals are presented showing the accuracy of the calculation. When you press **OK** from the “**Store this Point?**” dialog, you will be setup on the calculated point backsighting the first point measured in the resection.

The dialog box titled "Store this Point?" contains the following information:

- North: 1266417.0007
- East: 2065201.9556
- Elev: 5505.05
- Ang RMS(s): 8"
- Dist RMS: 0.0013
- Elev RMS: 0.0000
- StdDev N: 0.0012
- StdDev E: 0.0005
- Closure: 33208

Point ID:

Description:

Buttons: Green checkmark, Red X, and a menu icon (ABC).

A minimum of 3 angle-only measurements can also lead to an accurate calculation of the resection point, as shown below:

The dialog box titled "Review Resection" displays a table of resection data:

Pt ID	XY On	Z On	H Ang	Ang Residual	S Dist	Dist Residual	V Ang	Tgt Hgt
2	ON	ON	0°00'02"		0.0000	0.0000	90°00'00"	7.0000
3	ON	ON	185°38'20"	0"	0.0000	0.0000	90°00'00"	7.0000
4	ON	ON	160°18'43"	0"	0.0000	0.0000	90°00'00"	7.0000

Inst. Hgt:  Edit ON/OFF

Results:

- N: 4999.9943 StDev N: 0.000
- E: 5000.0025 StDev E: 0.000
- Z: 99.993 ZRMS: 0.0024
- Dist RMS: 0.000 Ang RMS (sec): 0

Select the Angle Only toggle before taking an angle only measurement with no distance. If the angle only measurements are accurate in the zenith angle to a specific location, an accurate elevation can also be calculated from as few as 3 angle only measurements with no distances. Within Angle Only mode, you do not need to change to reflectorless mode, since by definition no distance will be measured. You can stay in prism mode. If measurements are taken to steeples and radio towers and only x,y position is known or the precise elevation point to sight is not known, then only the x,y position of the occupied point will be determined accurately, and high Z RMS values will result.

During a Two-Point resection, the user will have the option to hold the first located point and the azimuth between the two located points by checking the ‘Angle Only’ checkbox – If the ‘Angle Only’ checkbox is unchecked, both located points will be held (normal resection).



## 6.16 Set Collection



The Set Collection routine allows you to collect and average sets of angles to multiple foresights.

### Setup

The opening dialog is the standard setup dialog shown below that allows the user to specify the instrument and backsight information.

**Set Collection**

Single Setup | Remote BM | Occupation

Occupy Point: 2

Instr. Height: 5.3 ft

Backsight Point: 1

Backsight N Azi: 269°22'21"

Backsight HT: 2 ft

Use Backsight HT for Foresights

Confirm NEZ | From Job | Backsight

-  **Configure:** This button displays the dialog shown below, and allows you to specify options available for the way the angle sets are to be collected.

**Configure**

General | Sets

Store Fixed Only (GPS)

Prompt for Total Station Setup

Prompt for Height & Description

Prompt for Point Notes

Prompt If Duplicate of Backsight or Last Reading (TS)

3D Mode

Use Virtual Keyboard

No. of Readings to Avg - TS: 1 GPS: 1

Enter/Store Icon - TS: Read & Store



For robotic total stations, the **Robotic Set** option is available.

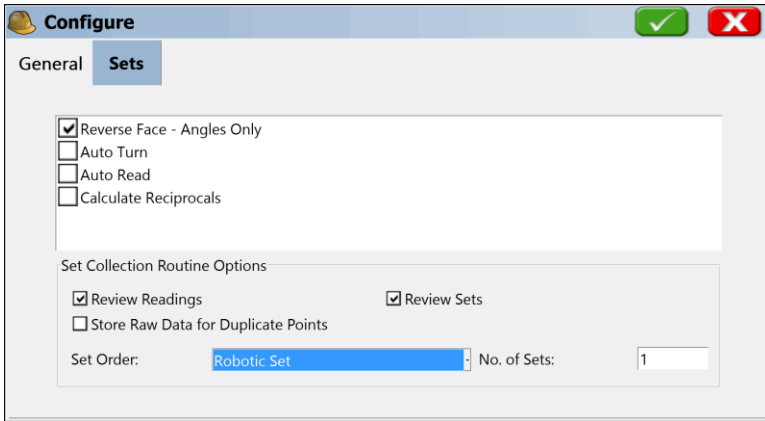

**Number of Sets:** This input box allows you to define the number of angle sets that are to be collected to each point. An angle set is defined as a direct and reverse reading to the backsight and the foresight (i.e. BD-FD/FR-BR). If multiple foresights are defined, only a single backsight-direct and backsight-reverse set of readings will be collected for all foresight points.

**Num of Readings to Avg (TS and GPS):** This input box allows you to specify the number of distance measurements that are to be taken during each sighting.

**Set Order:** This drop list allows you to specify the order the angles are to be completed. The definition for the abbreviations are:

- *Backsight Direct (BD)*
- *Backsight Reverse (BR)*
- *Foresight Direct (FD)*
- *Foresight Reverse (FR)*

Since the backsight dialog is the first reading in all cases, only the following options are available:

- **Robotic Set:** Only available for motorized, auto targeting instruments. This option will turn all reverse sightings without any assistance from the user. The order will be the same as BD-FD/FR-BR.
- **BD-FD/FR-BR**
- **BD-BR/FD-FR**
- **BD-FD/BR-FR**
- **BD-BR/FR-FD**

**Reverse Face – Angles Only:** This toggle is intended for use with non-coaxial instruments. Only direct face readings will be measured, and all reverse face readings will be for angles only.



**Auto-Turn:** This toggle will allow the motorized instrument to automatically advance to the next position if it was previously measured. The software will pause at the next location and wait for the user to initiate the reading.

**Review Readings:** This toggle will pause the software after every reading and display the measured data.

**Review Sets:** This toggle will pause the software after the completed set for review.

- **Confirm NEZ:** This button allows you to quickly verify the instrument and backsight coordinate values.
- **Backsight:** This button is required to initiate the first reading and backsight orientation for the set collection process. The following dialog will be displayed. The user must measure either an angle only or an angle and distance to the backsight in order to proceed with the OK button. The Set Angle selection will prompt a warning “For use with a backsight prism use Set Angle and Read”. It is recommended that the Set Angle or Set Angle and Read buttons be used to record the initial backsight reading.

OC Point:	3	BS Point:	2
BS AZI:	89°22'21"	BS Bearing:	N89°22'21"E
Inst Hgt:	5.300ft	BS Hgt:	2.000ft

Buttons: Set Angle, Check Angle, Check, Set Angle and Read

## Define Foresight Points

After the Backsight dialog is accepted, the next step in the process is to enter in the point IDs for all of the foresight points that you intend to sight. The dialog shown below is intended to receive predefined point IDs. To enter points, begin in the top left input box and work your way down to the bottom of the left column, then start at the top of the right column and work down to the end.

Pt ID	Job Used

Buttons: Add Pts, Delete



## Take Readings

Once the foresight points have been specified, the next dialog will be determined by the set order. If the next reading was to be FD, since the BD was already recorded, then the dialog will prompt as shown below. Pay attention to the prompts in these dialogs as they inform you as to which point and which face is expected based on your configured set order. Press the Enter button or select the OK button to record the reading.

**Set Collection**

Station: 3      Baksight: 2

**Turn to Foresight, Direct Set #1**

**Press Enter to Read Point 1196**

Target Ht:  ft

## Reading Review

Unless robotic sets are involved, after each measurement an optional Reading Review dialog appears where the measurement can be accepted or rejected. This option is set in Configure.

**Reading Review**

Point: 1196  
TargetHgt: 7.000  
H.Obs: 12°00'00"  
V.Obs: 90°00'00"  
S.Dist: 12.000

Accept Data?



The sequence of shots continues.

<b>Set Collection</b>	<b>Reading Review</b>
Station: 3      Backsight: 2	Point: 1196 TargetHgt: 7.000 H.Obs: 14°00'00" V.Obs: 270°00'00" S.Dist: 14.000
<b>Turn to Foresight, Reverse Set #1</b> <b>Press Enter to Read Point 1196</b>	Accept Data?
Target Ht: <input type="text" value="7"/> ft	<input type="button" value="Yes"/> <input type="button" value="No"/>
<b>Set Collection</b>	<b>Reading Review</b>
Station: 3      Backsight: 2	Point: 2 TargetHgt: 2.000 H.Obs: 14°00'00" V.Obs: 270°00'00"
<b>Turn to Backsight, Reverse Set #1</b> <b>Press Enter to Read Point 2</b>	Accept Data?
Target Ht: <input type="text" value="7"/> ft	<input type="button" value="Yes"/> <input type="button" value="No"/>

### Completed Set

At the end of the set collection process the Set Report dialog will be presented. If you had specified 2 points (or more) in the initial "Set Collection Point Order" screen, you would obtain a tabbed dialog of all the points to review.

**Set Report**

**PT 1196**

OP: 3   BS: 2   FS: 1196

	H.Ang.	V.Ang.	S.Dist.(ft)
F1 FS	12°00'00"	90°00'00"	12.0000
BS	0°00'00"	90°00'00"	0.0000
F2 FS	14°00'00"	270°00'00"	14.0000
BS	14°00'00"	270°00'00"	0.0000

After all of the **Reciprocal Calculation** and **Store Point** dialogs have been accepted, the dialog below will be presented.

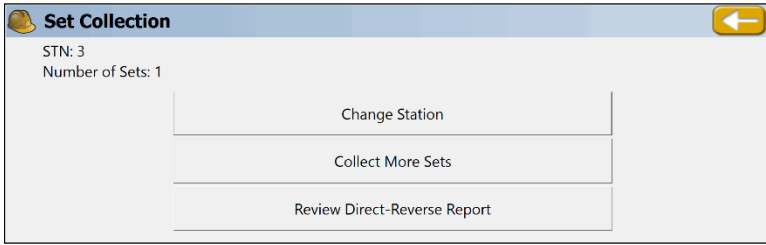

**Change Station:** This button will take you to the Instrument Setup dialog and advance the point numbers so that the original occupied point is the backsight and the last foresight point is now the occupied point.

**Collect More Sets:** This button will take you to the Backsight dialog and maintain all of the previous setup information.

**Review Direct-Reverse Report:** This button will allow you to select the occupied point ID from a list of points that were used with set collection. The software will then generate a report of all of the sets measured from the specified occupation point.

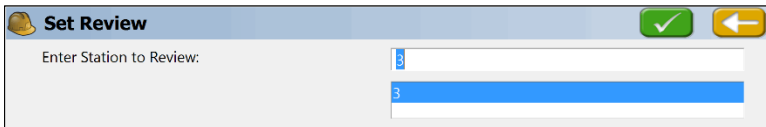

In the figure above, select a point number and tap OK to view the report. The report is shown below.

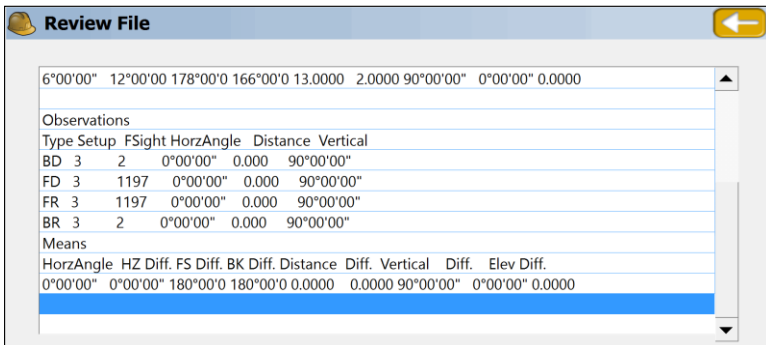



## 6.17 Leveling



This routine allows you to run trigonometric level loops using a total station or digital level loops using a digital level. There are also manual entry modes available for both types of level loops. The raw data collected for a total station is slope distance, zenith angle and prism height. For digital levels, the vertical difference and if available, the horizontal distance is stored in the raw data file.

The calculation routines assume there is only one loop per level file. A benchmark is required at the beginning of the loop (BM+) and a benchmark is required at the end of the loop (BM-). After the BM+, measurements back to a known elevation (TP-) and measurements forward to establish an elevation (TP+) are alternated. Any number of side shots to points (SS-) or stations (STA-) is allowed while traversing. Spurs (series of TP+ and TP- measurements off the main loop) are allowed and will be adjusted correctly. A spur after the BM- is allowed.

The opening dialog is where you set up the level loop. If road files are used, an additional tab in the leveling measurement screen will be made available for entering station and offset data. To use a digital level instead of the current total station, click the Select button to the right of the Instrument and choose from the available options, which include Manual 3-Wire, Manual 1-Wire, Manual Digital Level and Sokkia SDL. Manual Total Station entry can also be done by choosing **Manual Total Station** on the **EQUIP** tab.

Instrument:	Current Total Station	Select
Level File:	C:\Carlson Projects\Data\Level File Demo.tlv	Select
Project:	Demo	
Operator:	Peter	
Loop:	None	
Date:		Temp: 54
Time:		Press:
<input checked="" type="checkbox"/> Use Road Files		Select Road
Centerline:	C:\Carlson Projects\Data\DEMO.cl	
Profile:	C:\Carlson Projects\Data\DEMO.pro	

Use the **Select Road** button to choose the horizontal and vertical alignments you wish to associate.

Click the **Use Road Files** toggle to enable the use of the selected files. If Use Road Files is turned off, the STA+ tab will not be shown.

After the loop has been opened or created, select the Green Check button to advance to the measuring screens. The first reading of the loop must be a benchmark (plus) reading to establish the instrument height. Enter the point ID or known benchmark elevation, the prism height (trig levels), and a description. Then press the **Read** icon or **Enter** to





measure. Once the reading has been taken, select the **Store** icon to keep it. You can take as many readings on a single point in any face that you like. You can also review the readings and disable any that you don't like prior to storing.

**Leveling**

BM - TP - SS - STA-

Pt ID: 3 **HI: 253.194** ft

HT: 2 ft BM Elev: 251.083 ft

Desc: Radio1

SD: 7.568 ZA:270°00'00" VDiff: -0.000

Avg Elev: 251.194 Elev Spread: 0

Reading Count: 2

Review Readings

R  
S  
C  
+

**Leveling**

BM - TP - SS - STA-

Pt ID: 3 **HI: 253.194** ft

HT: 2 ft BM Elev: 251.083 ft

Desc: Radio1

SD: 0.000 ZA:270°00'00" VDiff: -0.000

Avg Elev: 251.194 Elev Spread: 0

Reading Count: 4



Review Readings

Level  
Digital Level  
Wrench and Gear  
+

Some of the fields below only apply to one of the Leveling types. See screen shots above to see which apply.

- **Pt ID:** Use this field to retrieve the elevation from an existing point in the coordinate file.
- **HT:** Use this to enter the prism height. If using a digital level, this field will be gray, and will be populated with the rod reading from the level.
- **BM Elev:** Enter a known elevation for the benchmark. This field will auto-populate if a point ID is selected.
- **Desc:** Enter the point description.
- **Review Readings:** This allows you to enable or disable specific readings prior to storing.



- **Robotics:** Use this to control the robot.
-  **Read:** Use this icon to take a reading.
-  **Store:** Use this icon to store the reading.
-  **Configure:** Use this icon to setup direct and reverse settings and review options.

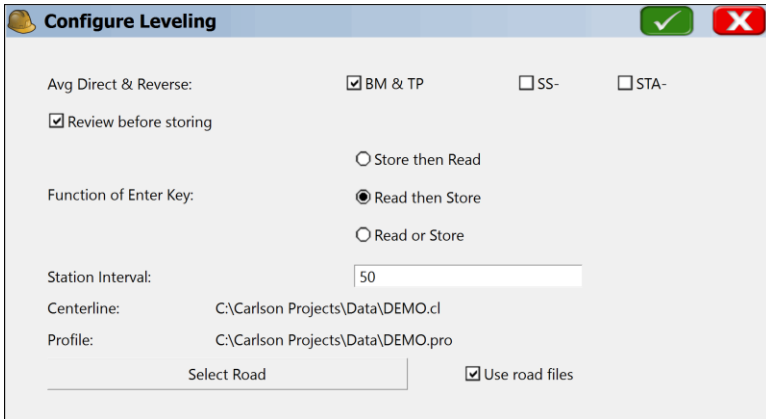

**Configure Leveling**

Avg Direct & Reverse:  BM & TP  SS-  STA-

Review before storing

Function of Enter Key:  Store then Read  
 Read then Store  
 Read or Store

Station Interval:

Centerline:

Profile:

Use road files

- **Avg Direct & Reverse:** This option will allow you to determine which readings take direct and reverse pairs. (only applies to Trig Leveling)
- **Review before storing:** This toggle forces the **Review Readings** dialog prior to storing. This is the same dialog that comes up when the **Review Reading** button is pressed except the Review Reading dialog has a Store Point button that stores the shown measurements



**Store Level Data** ✓ ←

Status	Z Ang	S Dist	Elev
ON	90°00'00"	0.000	253.083
ON	270°00'00"	0.000	253.083

Pt ID: 2 HT: 2 ft

Results

Avg Elev:	Sel Error:
Vert Spread: 0.000	Min Elev:
Std Dev: 0.000	Max Elev:

The **Status** field shows if the measurement is turned on or off. Measurements that are off will not be used in any calculations. Elev shows the calculated elevation which will be the elevation at the total station or level on a plus shot (BM+ or TP+) or the elevation at the rod on a minus shot (BM-, TP-, SS- or STA-).

Any measurement can be highlighted by clicking on the measurement. A measurement must be selected before using **Edit Reading** or the **ON/OFF** button.

All the values in the Results section are about the elevation calculations. The **Sel Error** field shows how different the calculated elevation of the currently selected measurement is from the mean of all the measurements that are on.

Once a benchmark (plus) reading has been taken and stored, the **Minus Reading** dialog will be shown. This dialog allows you to read the minus reading to a turning point (TP), benchmark (BM), sideshot (SS), or a sideshot on an alignment (STA). Turning points advance the setup while sideshots do not. A reading to the benchmark in the minus screen will end the loop.



**Leveling**

BM - **TP -** SS - STA -

Pt ID: 3 **HI: 251.083** ft

HT: 2 ft

Desc: Radio2

SD: 101.000 ZA:270°00'00" VD:Diff: -0.000

Avg Elev: 249.083 Elev Spread: 0

Reading Count: 2

Review Readings

R  
S  
C  
+



**Level Reading Mode:** This icon switches the interface between taking plus or minus readings.

At any time during the loop, you can edit a reading using the **Edit Levels** icon to the left of the red X (Cancel) button.

**Edit Levels**

Date:04/03/2017 Time:10:48:18 Press: Temp:

Rod:0.000

BM Pt:6 Z:97.000 Desc:BM

BS Pt:6 VD:8.000 HD:100.000 Desc:BM

FS Pt:7 VD:2.000 HD:100.000 Desc:

BS Pt:8 VD:10.000 HD:100.000 Desc:

FS Pt:8 VD:12.000 HD:100.000 Desc:

BS Pt:8 VD:7.000 HD:100.000 Desc:

FS Pt:6 VD:10.950 HD:100.000 Desc:BM

Add Edit Del/Undel Process

Once the minus reading on a benchmark has been recorded, you can then process the loop using the Process icon which is to the left of the Edit Levels icon. Once you've processed the loop, a Review File dialog will be displayed. At this point you can choose to save the report or proceed to the Processing Options screen.



**Review File** ✓ ↺ ←

Processed 04/03/2017 10:39:47

Length(-): 0.000  
Length(+): 7.567  
Loop Length: 7.567  
Closure: No Ending Benchmark  
Error: No Ending Benchmark

Loop: None  
Operator: Peter  
Project: Demo  
Created:  
Press:  
Temp: 54  
Units: US Ft

The Processing Options screen allows you to update all existing points in the coordinate file with the leveled elevations. It also allows you to overwrite the point descriptions using what was entered during the level loop and will compute coordinates for any points that were defined by station and offset.

**Update Points in Job** ✖

Pt ID	Orig El	New El	El Diff	Desc
2	251.083	251.083	0.000	Radio1
3	291.067	251.194	39.873	Radio2

Use Adjusted Elevations       Use Level Descriptions

Store STA- as Points      Skip Existing

Save Report      Update Job



## Manual 1-Wire Example

If you select the 1-Wire method of Leveling, the graphic below may be helpful in selecting the options to conduct a simple level loop:

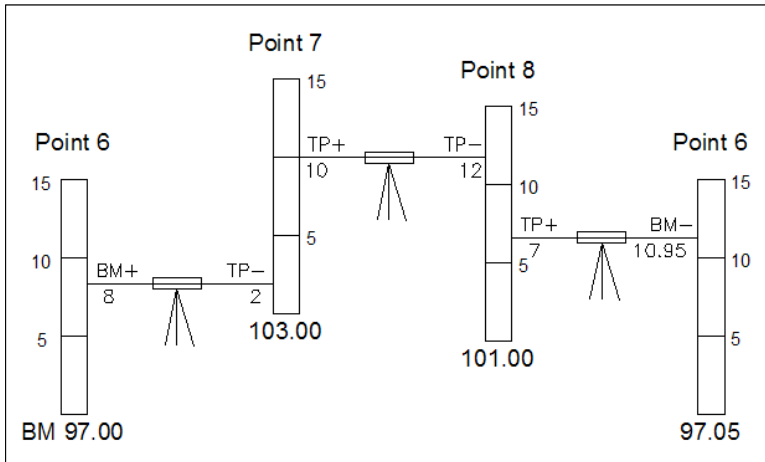

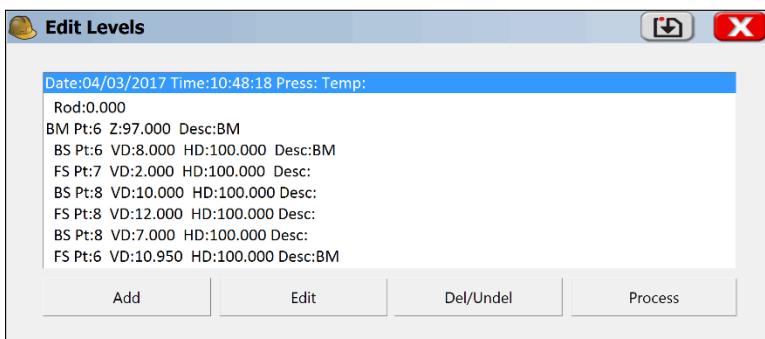

You "+" to your "backsight" and you "-" up to your foresight, and you name the points as you go. You start by referencing a benchmark, and you close the loop by referencing the starting point or a second benchmark.

After entering the example, pressing the Edit Levels icon shows all the measurements made. All the horizontal distances (HD) are shown as 100 because 1-wire leveling does not provide a horizontal distance. Giving all the segments the same distance causes the level adjustment to give all the segments the same weight.



Pressing the Process icon shows the results.





**Review File**   

Processed: 04/03/2017 10:54:24

Length(-): 300.000  
Length(+): 300.000  
Loop Length: 600.000  
Closure: 0.050  
Error: 1:12000

Loop: Short 1-Wire  
Operator: Ken  
Project: Example

Scrolling to the end shows the adjustments that will be applied to the last two measurements.

**Review File**   

TP+  
PT: 8 Desc:  
VD: 7.000 HD: 100.000  
dZ: -7.000 HI: 108.000  
Adj: -0.042 AdjHI: 107.958

BM-  
Pt: 6 Desc: BM  
VD: 10.950 HD: 100.000  
dZ: -10.950 Meas: 97.050  
Adj: -0.050 BM: 97.000

Pressing the green check icon brings up the Update Points in Job dialog.

**Update Points in Job** 

Pt ID	Orig EL	New EL	El Diff	Desc
6	97.000	97.000	0.000	BM
7		102.983		
8		100.987		

Use Adjusted Elevations  Use Level Descriptions

Store STA- as Points

**Save Report** will put the information shown in the **Update Points in Job** dialog into a text file for your records.

**Update Job** saves the new elevations to the points in the job. **Skip Existing** will not replace a point's elevation if it already exists but **Replace Existing** will.



## 6.18 Auto by Interval



**Auto by Interval** allows you to acquire and store data at a set interval value of either distance or time. This function is available with all GPS or certain robotic total stations only.

**Robotic Total Stations:** When the routine is selected using a robotic total station with Prompt for Setup within Configure on, you will be directed to a **Confirm Orientation** dialog, in which you will be asked to confirm your orientation. The opening or main dialog appears as shown below.

Setup	Remote BM	Robotics	Occupation
Occupy Point:		1197	[List Icon] [Clear] [Refresh]
Instr. Height:		5	ft
Backsight Point:		1196	[List Icon] [Clear] [Refresh]
Backsight N Azi:		278°22'01"	
Backsight HT:		5	ft
<input type="checkbox"/> Use Backsight HT for Foresights			
Confirm NEZ		From Job	Backsight

After the backsight is confirmed or measured, the **Auto Store by Interval** dialog will appear as shown in the figure below. In GPS mode, you will see the Auto Store by Interval dialog immediately. In the Auto Store by Interval dialog box, you set the type of interval (distance or time) and the value of the interval. You also set the starting point number for the data set. You can assign a point description for all points acquired with this command. During actual data collection, you can change the description.

Auto Store by Interval		✓	✗
<input checked="" type="radio"/> Distance	X/Y:	10.0000	ft
	Z:	10.0000	ft
<input type="radio"/> Time		10	s
Starting Pt ID:		1211	
Description:	CP	[List Icon]	
<input type="checkbox"/> Record Max Number of Points:			100





Data is acquired in the standard collection **MAP** view screen. The point ID, description, and rod height fields can all be changed while the command is active. For example, to change your point description from td (top of ditch) to gr (ground shot), simply type "gr" over the "td" in the Desc field without interrupting your collection.

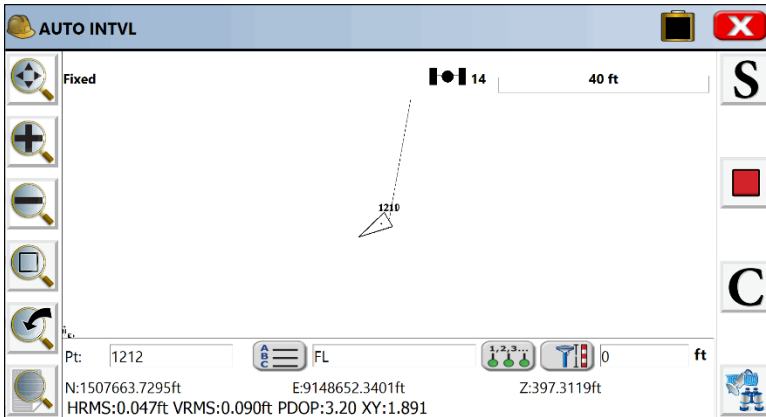

- **Store:** Pressing the **Store** icon immediately stores the point at your current location, overriding the interval.
- **GPS Start and Stop:** This button alternates between stop (square, red) and play (arrow, green) icons. While the GPS is running or the robotic total station is tracking, the stop icon allows you to stop the surveying equipment from taking readings. When the button is pressed, the GPS or robotic total station stops, and the button switches to the play icon, which can be pressed to resume the readings.
- **Monitor/Skyplot:** This button can be found on the bottom right of the **MAP** screen for GPS. This "binocular" icon opens the **Monitor/Skyplot** dialog.

*Note: In GPS mode, if you run Auto Points at Interval and points do not store, check that your RMS tolerances for storing are not set too low. Points will be stored only when your RMS values are less than those specified in tolerances under the EQUIP tab. Also, note that you may find that the points store at a distance apart exceeding that specified by your interval due to latency and your speed of movement.*

*Note: Auto by Interval will display a red status bar whenever an error / blunder is detected.*



## GPS Receivers:

For GPS Receivers, this routine allows you to store a point automatically as soon as the receiver is level. To use this feature, select Equip – GPS Rover. In the Receiver tab, enable the Use IMU option. Select the green check to continue. Please note the 5Hz minimum position rate with this feature: If less than 5Hz is selected afterwards, the IMU feature will be disabled.

The screenshot shows the 'GPS Rover' configuration window with the 'Receiver' tab selected. The window has a title bar with a yellow helmet icon, the text 'GPS Rover', and three buttons: a blue 'T' icon, a green checkmark, and a red 'X'. Below the title bar are four tabs: 'Current', 'Comms', 'Receiver' (highlighted), and 'RTK'. The main area contains the following settings:

- Antenna Type: [HEMS321 NONE] Integrated
- Antenna Height: 0 ft Abs. 131.9mm
- Elevation Mask: 10
- Position Rate: 5 Hz
- Use IMU
- Audio Mode: On
- Radio buttons:  Vert,  Slant
- Advanced button

To view the electronic bubble on the screen, please go to Equip – Configure and select the IMU tab. In the IMU tab, the option to ‘View GNSS Level’ is available to enable / disable.

The screenshot shows the 'IMU Settings' configuration window with the 'IMU' tab selected. The window has a title bar with a yellow helmet icon, the text 'IMU Settings', and two buttons: a green checkmark and a red 'X'. Below the title bar are three tabs: 'General', 'View', and 'IMU' (highlighted). The main area contains the following settings:

- Vertical Pole LDL:  View GNSS Level
- Inclined Pole Corrections:
  - Correct Tilted Pole
  - Check for unit motion



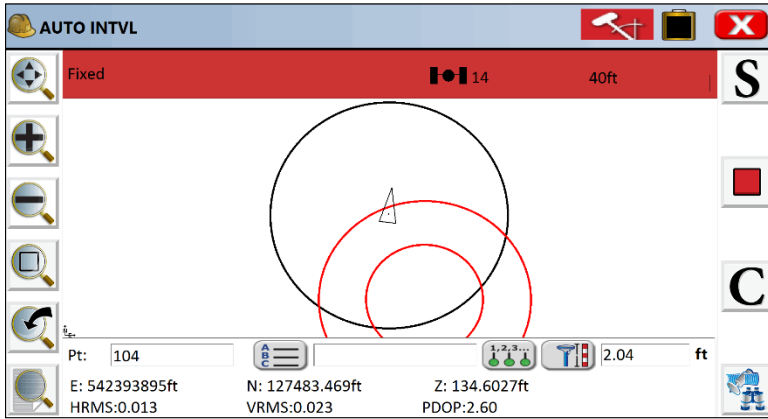

As soon as the receiver is level for the specified length of time, a point will be stored. If you selected the Audio option in Equip – GPS Rover, an audible alert will sound.

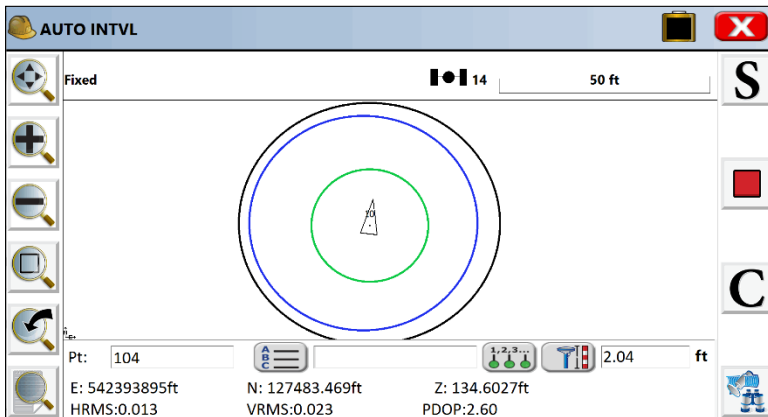



## 6.19 Remote Elevation



This command allows you to observe a point that cannot be reached vertically, such as a power line, building top, etc. The routine uses two observations - one for the base point and one for the vertical angle to the target object. The routine then calculates the target point's elevation.

By placing the prism below or above the desired point, Carlson SurvPC stores information about the base point. Then you can take a second reading, observing only the zenith/vertical angle to the true target point. Using these two observations, SurvPC calculates the intersection of the extended zenith/vertical angle with a vertical line from the base point to determine the elevation. Reporting includes the elevation of the target object as well as the elevation difference between the prism and the target object.

Steps to take a remote elevation reading are as follows:

1. Select **Remote Elevation** from the **SURVEY** tab of the main menu.
2. Confirm your orientation, and re-shoot the backsight as necessary.
3. Press **Enter** to observe base point (see the figure below). Point the instrument toward the target and press **Enter**.

**Remote Elevation** ✓ ✕

**Press Enter to Read Base Point.**

Target Ht:  ft

Press Enter to shoot target elevation (see the figure below). Sight instrument on the desired point (such as a wire or top of pole or point on a building) and press Enter.

**Remote Elevation**

Press Enter to Read Target Elevation.

OK Cancel



Back in the REM ELEV screen, your angle, zenith, and distance are shown, along with the remote height and remote elevation.

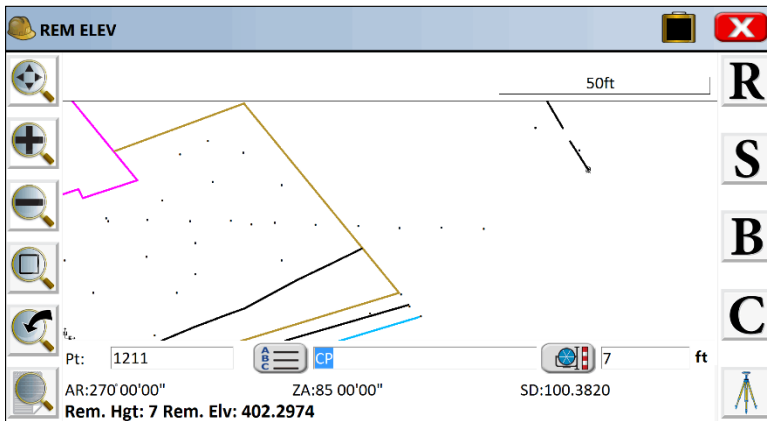

- **Read Icon:** This allows the user to take additional shots above or below the previously defined base point. Pressing the Enter key will also repeat this command.
- **Store Icon:** This button stores the current target offset point to the job file
- **Configure Icon:** This takes you to the **Configure** settings also found on the EQUIP tab.
- **Instrument Icon:** This takes you to the standard **Instrument Setup** dialog.



## 6.20 Log Raw GPS



This command allows you to log static data to the receiver or a data card (depending on instrument type) for use with post processing software. If a raw data log file has been started through SurvPC, points stored by Average or Single Store methods (not Auto by Interval) will be tagged in the raw data log file automatically given the receiver supports this feature.

### Post Processing (Logging Static Data)

Go to the SURVEY tab and select the **Log Raw GPS** button. You will see a screen with options (see the figure below), or an error message stating that the PC could not connect to the receiver. If you receive an error message, check connections and the data card.

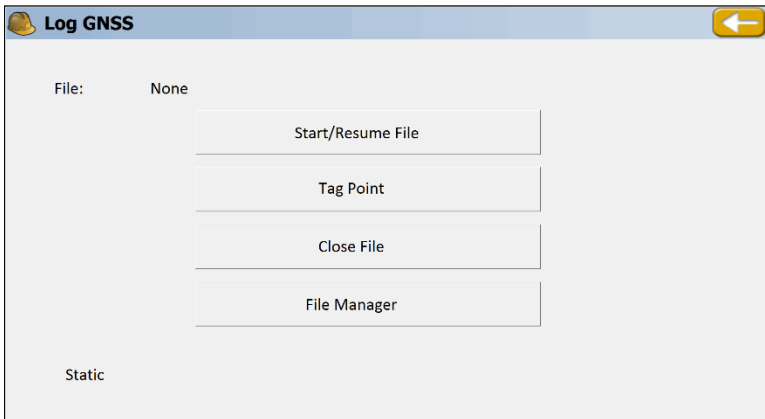

Tap on the **Start/Resume File** button to start logging raw data. From this point, you can choose the **File Manager** button to see what files are on the receiver's card. You can delete files here if memory is low. More information on the **File Manager** dialog will be covered later.



The **Tag Point** dialog contains place to enter a new Site Name, Antenna Height, Antenna Type, and [Logging] Interval as shown in the figure below.

**Tag New Site**

Free Mem on Receiver:

File:

Site Name:

Ant. Height:

Interval (in Seconds):

Close Site Tag:  
 Manually  After  minutes

Next is the **Tagging Site dialog**. To start tagging a site, enter the information requested including site name, site code, and antenna height (changing is optional--see Changing the Antenna). You will also decide here whether you want the site to stop automatically after a duration of your choice, or when **End Site** is selected. Tap **Start Site**, and all the information entered will be grayed out until the site is ended. Stop the site at any time by clicking **End Site**. Before ending the site, you will have the option to change the antenna information (in case you made a mistake). View the satellite status at any time using the **View Status** button. This will not affect the tagging of the site.

**Logging to file 'file0001'...**

Site Name:  Site Duration: 00:00:01

Site Code:

Antenna Height:  File: file0001

File Duration: 00:00:58.0

Stop Logging:  
 Manually  After  minutes

GDOP: 3.5 PDOP: 3.0 HDOP: 1.7 TDOP: 1.8 SATS: 5

You can tag as many sites as you wish. When you are done, click the **Exit** button. SurvPC will ask you if you want to continue logging the file. If you do, click Yes, and the next time you select **Log Raw Data**, you will go directly to the dialog box shown above. The file name will appear in the main post process screen if it is being logged. If you wish to leave the receiver logging, you can exit the setup, and the next time you come back to post processing, the software will know you are still logging a file.





## File Manager

Under the SURVEY tab of the main menu, select the Log Static Data button. You will either see a screen with three buttons, or an error message stating that the PC could not connect to the receiver. If you receive an error message, check connections and the data card. Click on the File Manager button to see what files are on the receiver's card. In this dialog, you see a list of files, along with their respective sizes.

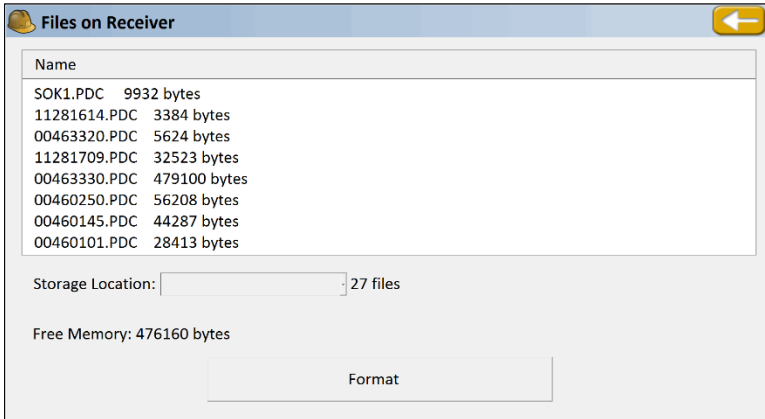

If you want to manage the files (to see how much memory they are using and to delete files) on the receiver, click the File Manager button. If a file is open, you can now tag sites. Otherwise, open a file by clicking the Start File button.



## 7 Cogo

This chapter provides information on using the commands from the COGO menu.

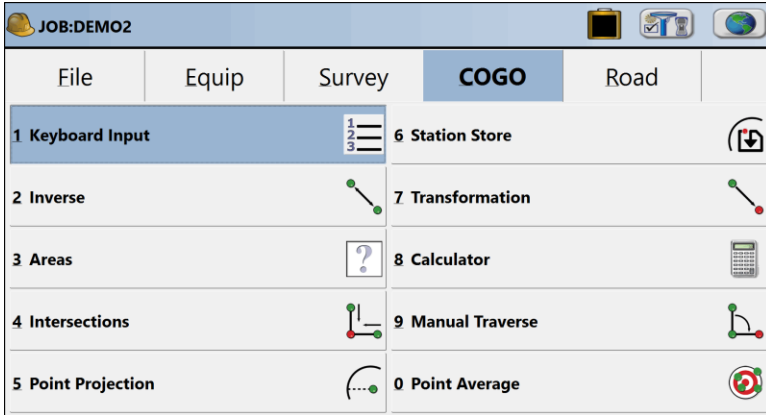



## 7.1 Keyboard Input



This feature allows you to manually enter or edit coordinates in the current job file or the current control file. The option to edit points in the control file only appears if **Use Control File** is enabled in **Job Settings**. There are fields for Point ID, Northing, Easting, Elevation and Description. If adding a point to an existing job, SurvPC displays a point ID one greater than the highest in the file. If starting with a new job, the point ID will default to 1.

**Enter and Edit Coordinates**

Type CRD: Alphanumeric

Source:  Job  Control

Point ID:

Northing:  ft

Easting:  ft

Elevation:  ft

Description:

- **Previous and Next:** These buttons move back and forth through the coordinate file, skipping points with zero coordinates. The **Next** button will not store the current data to the file.
- **Store:** This writes the entered data to the file and advances the display to the next point. If you are editing an existing point, when you press **Store**, SurvPC will warn you that the point number has already been used. You then have a choice to overwrite this point number or use a new number.

*If you want to create a duplicate point, simply change the point number and press Enter or Store to save it.  
If you a duplicate point with a different elevation, change the point ID and elevation and press Enter or Store to save it.*



- **Utilities:** The Utilities button allows the user to modify or delete a point or range of points. The Utilities screen appears below:

Point Utilities

Range of Pts: 2-5

DESC: IP (Found)

Modify Delete

There are two uses of the command: to Delete a point or range of points, and to Modify the descriptions of a point or range of points. For example, if you wished to assign the description "IP (Found)" to points 3 through 5, you can enter the point range and description as above, and then tap "Modify". You will have a confirming screen as shown below:

SurvPC

Are you sure you want to change the descriptions for the range of points: 2-5 to IP (Found)?

Yes No



## 7.2 Inverse



This command reports the bearing and horizontal distance between any two user-specified points that are contained within the current job. If under **Units in Job Settings**, Angle is set to Azimuth, then inverse will display azimuths instead of bearings. You can override the display settings in the **Point Inverse** screen by choosing between Bearing (Brg N,E or Brg E,N), North Azimuth (NAz N,E, NAz E,N) and South Azimuth (SAz N,E or SAz E,N) at the bottom right of the Inverse screen.

Inverse can be run in either 2D or 3D mode as selected at the top of the screen. In 2D mode, the program displays only the bearing and distance between the two points. As many as 7 inverses can be viewed at once, as shown below.

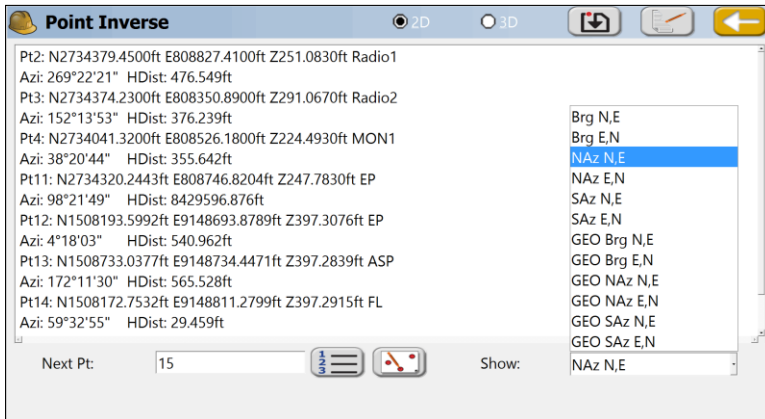



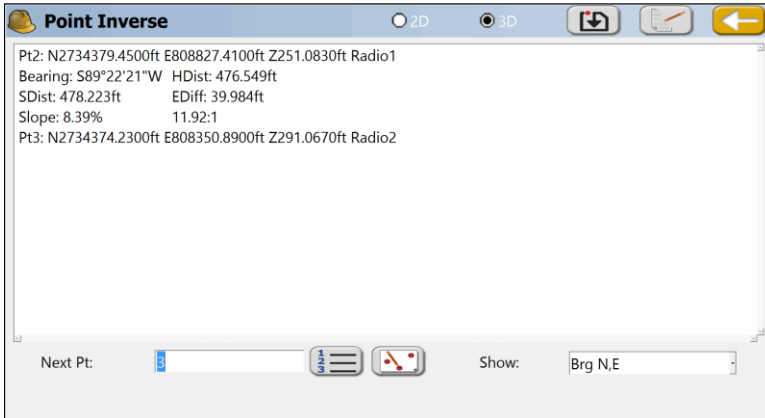

In 3D mode, the report also displays the slope distance, elevation difference, slope in percent, and slope as a ratio, between each point. The Northing, Easting, Elevation and description of the specified points are also shown.



To run the inverse routine, enter the first point number at the bottom (you may also select from a point list or select from the map screen). Press **Enter**, and then input another point and press **Enter** again.

If a control file is specified in **Job Settings**, then when you run inverse, you can choose the List icon at the bottom center of the screen and then select points from the control file. In this way, you can inverse between points in your current file and your control file as needed.

If under **Units** in **Job Settings**, Angle Unit is set to Grads/Gons, then the Inverse command will default to the 400 circle and will display North azimuths.

-  **Clear Command:** Use this icon to clear the results window.
-  **Save Command:** Saves any inverse to a TXT file, and will auto-append data if the same TXT file is used.

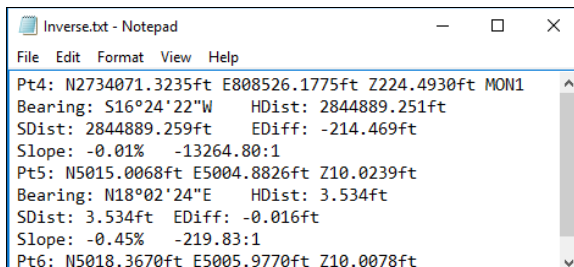



## 7.3 Areas



This command calculates the area of a closed figure that is defined internally by user-entered point numbers contained within the current job, or by a polyline picked from the screen. The polyline method allows selection of figures with arcs.

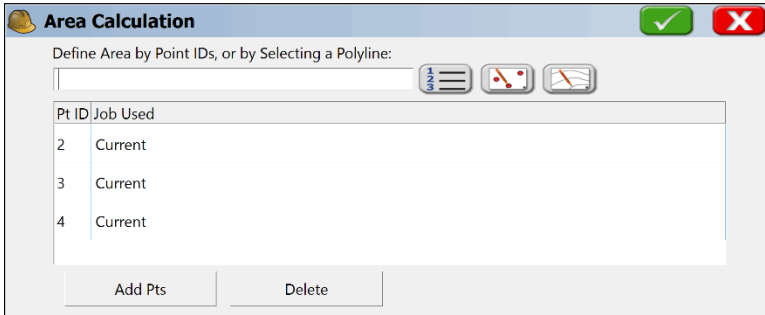

You may specify individual point numbers or type in a range of point numbers to define the area. Individual point numbers can be entered as 2, 3, 4 or each number followed by Enter. After clicking OK (green checkmark), the area is reported at the bottom of the map screen. A temporary polyline is also drawn between the points. Results are reported in square feet and acres when units are set to feet, and square meters when units are set to metric.

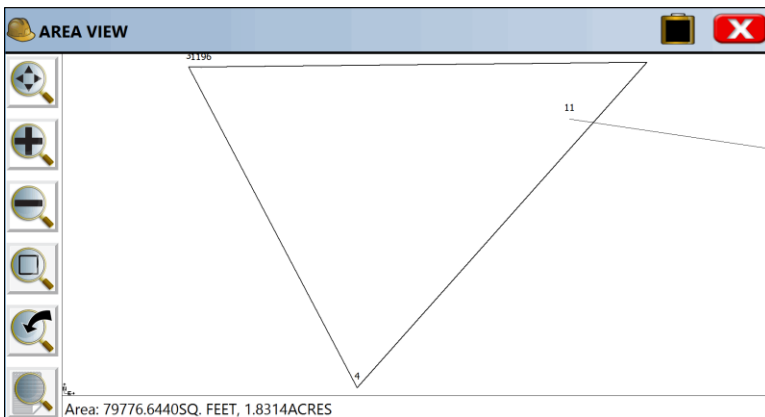



If the polyline method is used to solve the area, the program will bring up the MAP screen where you pick a polyline. Since the area can be written to a raw file (see below), you can use the direction icon in the lower right of the screen to confirm or change the direction that the polyline is drawn.

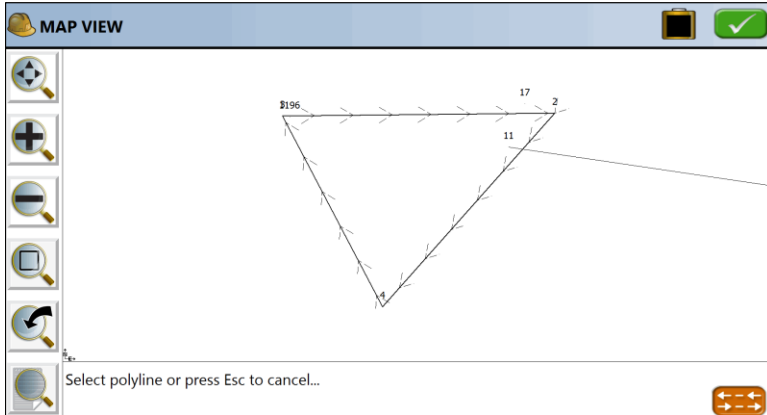

When you are certain that you have selected the desired polyline, press **OK**, and the graphic screen presents the area. Since the point-defined area is a straight point inverse, the advantage of the pick polyline approach is that the polyline may contain arcs.

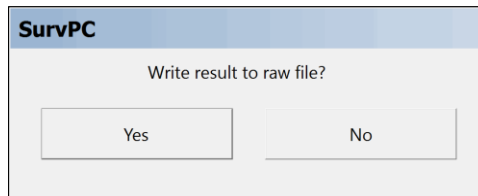

At the end of each area calculation, you are asked if you would like to “Write result to raw file?” This will write a line in the raw file as "Calculate area of polyline 2, 3, 4, : Area = 79776.6440SF, 1.8314 Acres." For point-defined figures in metric, the raw file record presents square meters.





## 7.4 Intersections



This command allows for the calculation and storing of points based upon standard surveying practices of Bearing-Bearing, Bearing-Distance, or Distance-Distance Intersection calculations. Data can be entered manually or defined by selecting points from a point list or map. The kind of intersection calculation to be performed determines the number of possible solutions. With a Bearing-Bearing calculation, there will be only one possible solution. Bearing-Distance, and Distance-Distance calculations will have two possible solutions prompting the user to pick the desired solution. Note that in intersection calculations of Bearing-Distance and Distance-Distance there may be no solution for the input data. In these cases, Carlson SurvPC will display the message, "No Valid Solution."

From the **COGO** Menu, select **Intersections**. Fill out the appropriate data fields to perform the desired calculation. The **Enter** key moves forward through the edit boxes. The current Angle setting in **Job Settings, Units**, dictates whether angles are prompted as azimuth or bearings.

- **Off:** Use these edit controls to create intersections that are defined by parallel offsets to the defined or computed direction.

All Intersect routines create SP records in the raw file, storing the calculated coordinates for each new point. This SP record is identical to records created by keyboard input.



## Bearing-Bearing

This method locates a point at the intersection of two lines. Select Point 1 by entering the desired point number or pressing the **Point List** icon and selecting the desired point. Pressing the **Map** icon will allow for selection of the desired point directly from the screen.

*Note: when selecting a point from the screen, if the desired point cannot be determined from the picked point on the screen, a listing of the nearest points to the desired location will appear allowing for verification of the targeted point. If the list appears, select the desired point from the list by clicking on it.*

Define the bearing from the first point by typing in the bearing or by specifying two point IDs. Repeat the procedures for defining the bearing from the second point.

Bearings can be entered in three forms:

- SE40.5945 becomes S40d59'45"E
- S40.5945E becomes S40d59'45"E
- 240.5945 becomes S40d59'45"E

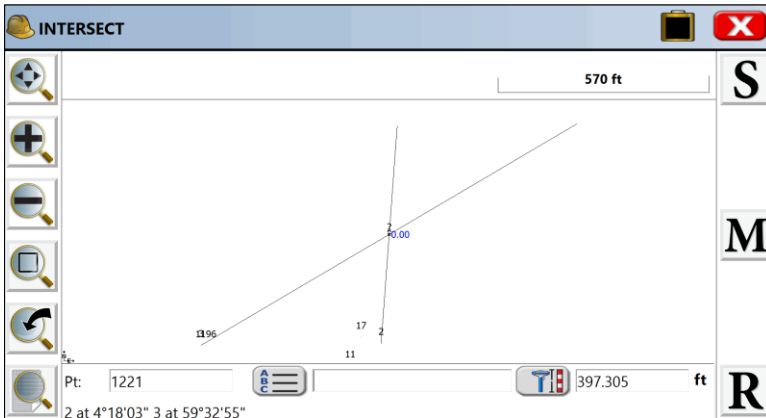



Once data entry is complete, press the **OK** button. The calculated point will appear on the screen with the input data detailed at the bottom of the screen. Store, Modify (review and revise) and **RESULTS** Options are located on the right side of the **Map** screen.

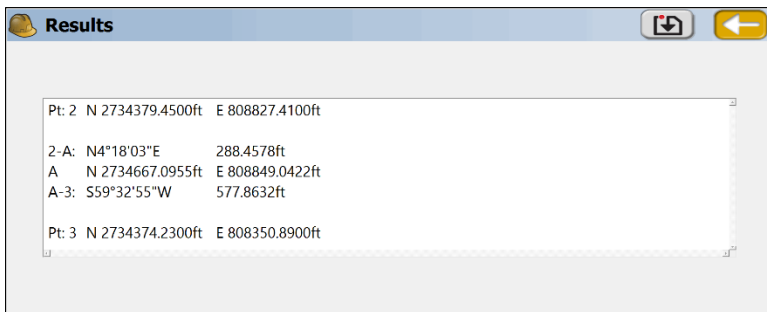
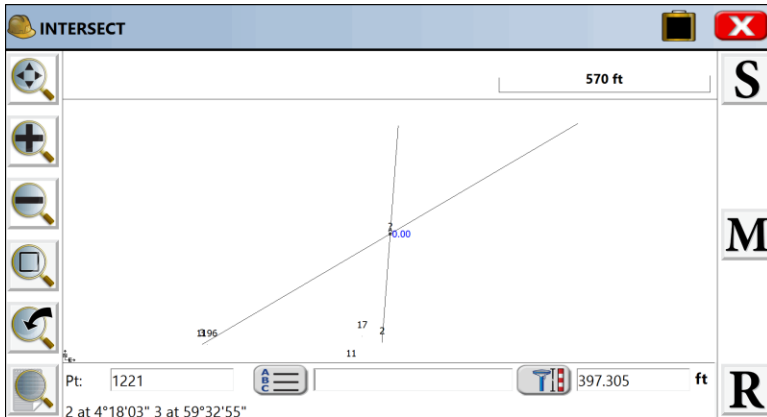

-  **Save:** Use this icon to save a report of the inverse.

The results screen will display the coordinates of the base points, the inverse bearing, the distance from the base points to the calculated INT1 point (and INT2 for distance intersections), and the coordinate data for the calculated points. Note that calculated points are labeled as Int1 and Int2 until the points are stored. These Option Buttons are present on all **Map** screens displayed while in the Intersections routine. Once **Store** is selected or the **Enter** key pressed, the stored point will inherit the specified point number, description, and the elevation displayed at the bottom of the screen (optional). There can be only one solution for a bearing-bearing intersection.

All Intersect routines handle the 400 circle, if configured to grads/gons within **Job Settings, Units**.



## Bearing-Distance

Define the Bearing from the first point, then define the known horizontal distance from the second point.

**Intersections**

First Point

Point ID: 1

Azimuth: 235°12'11" ° Use Points

Distance: ft Off: ft

Second Point

Point ID: 2

Azimuth: ° Use Points

Distance: 40.000 ft Off: ft

Select **OK** and the map screen will appear showing a circle radiating from the distance base point and a line from the bearing base point, defined by the entered bearing. The line is extended to intersect the circle at the two possible solutions.

Pressing **Enter** or **Store** will display the prompt "Pick a Solution". To select the point, simply pick it from the screen. Picking near the desired solution is sufficient. The program will select the nearest solution position. Pressing **Enter** again will accept the second possible solution for the intersection.

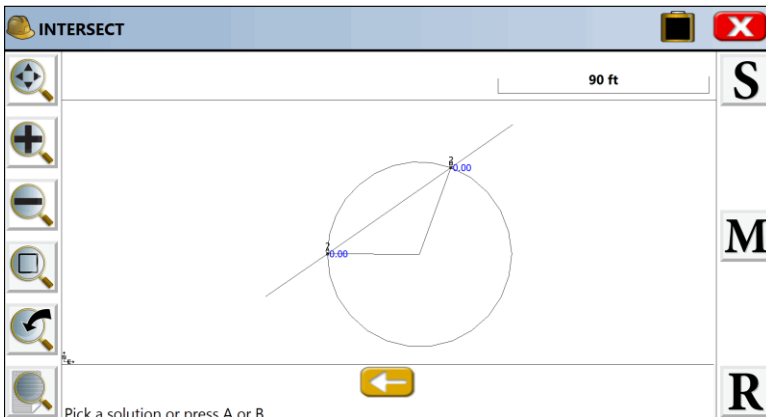



## Distance-Distance

Enter the known horizontal distances from both points.

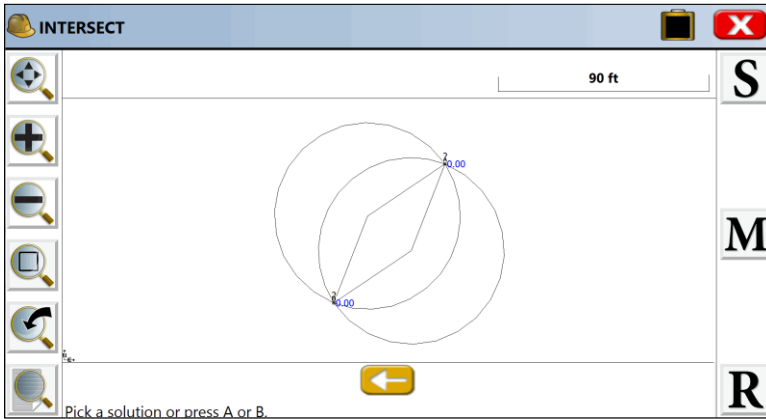

Select **OK**, and the map screen will display showing circles radiating from the first and second selected base points. Lines leading from both base points to the two possible intersections of the circles are also shown.

Pressing **Enter** or **Store** will display the prompt "Pick a Solution". Select the desired calculated solution. To select the point, simply pick it from the screen. Picking near the desired solution is sufficient. The program will select the nearest solution position. Pressing **Enter** again will accept the second possible solution for the intersection. If there was no solution for the input data, SurvPC will display "No Valid Solution".



## 7.5 Point Projection



This command allows you to calculate the station and offset of any entered or surveyed point relative to a known centerline or baseline. Note that the Station Store command will calculate a point at a given station and offset. Point Projection does just the reverse — it calculates a station and offset for any given point. It also will calculate the “Intersect”, or the projection of that offset point on the baseline. This baseline “intersect”, or perpendicular projection point, can be staked out and stored. The application of the routine is shown below.

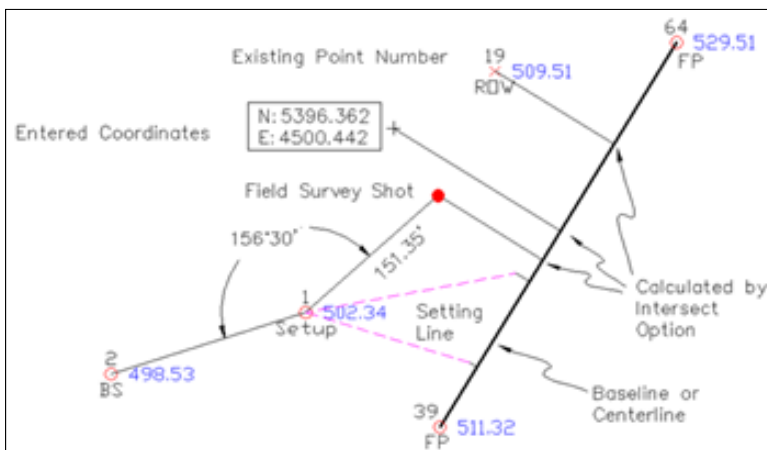

The coordinates from which to project can be entered in three ways:

- By point number
- By entering the coordinate values
- By taking a GPS or total station reading

The station, offset, and vertical difference of the point is then calculated, and the **Intersect** button (see the above figure) will calculate the projected perpendicular intersect point on the baseline. This Intersect can also be staked out using the Stake button.

You must first define the baseline. You can define the baseline by one of the following methods:

- Define Line: Select two points to define the line.
- Define Alignment: Select a predefined centerline file (.cl file), graphically pick a polyline or enter a sequence of points.
- Define Arc (3 Points): Select three points on the arc.
- Define Arc (PC, PT, Value): Select the start and end points of the arc and enter the radius length.

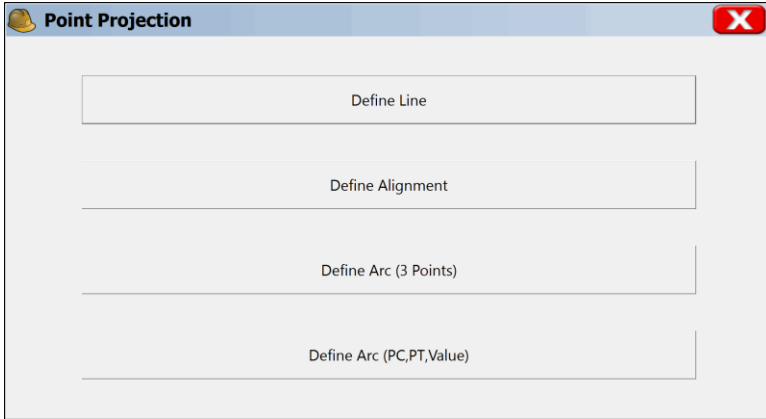

The **Point Projection** dialog box contains four stacked input fields for defining a line:

- Define Line
- Define Alignment
- Define Arc (3 Points)
- Define Arc (PC,PT,Value)

If you choose **Define Line**, you must then define the line in the dialog box as shown below.

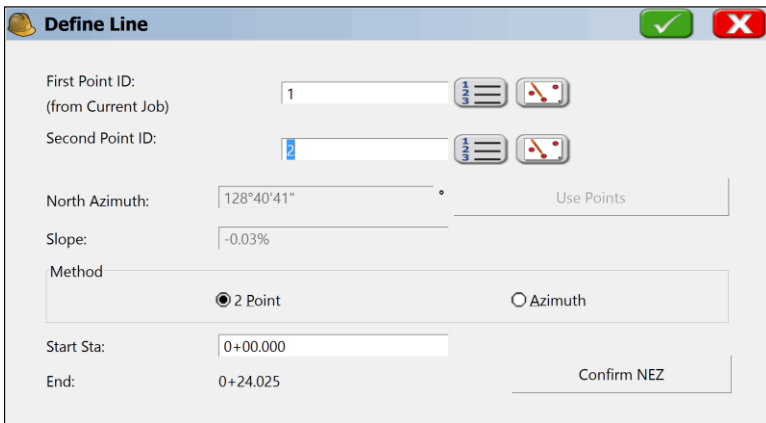

The **Define Line** dialog box includes the following fields and options:



- First Point ID: (from Current Job)  [Point List] [MAP]
- Second Point ID:  [Point List] [MAP]
- North Azimuth:  °
- Slope:
- Method:  2 Point  Azimuth
- Start Sta:
- End:

### Method(s)

- With the **2 point** method, you simply enter two point numbers, or choose them from the point list or MAP. The azimuth and slope between the two points is calculated, along with the ending station, based on the entered start station.
- With the **Azimuth** method, you define the line by entering a first point and then entering an azimuth and slope. You can confirm the coordinate values of the points by choosing **Confirm NEZ**. When the line is defined, choose **Continue**. You must now define, or designate, the point that is offset from the line in the **Point Projection** dialog.



**Point Projection**

Point ID:   

Northing:  ft

Easting:  ft

Elevation:  ft HT:  ft

Desc:  

Centerline: Pt ID:1 North Azimuth:128°40'41"  
Station: -0+07.358 Offset: Right 24.801ft  
Elev at PRO: 397.2925ft  
Vert Diff: F 0.0099ft

You can enter a point ID, select one from the list, or select one from the map. You can also enter coordinates to define a new point, or read values from the instrument. As soon as enough information is entered, the station, offset and vertical difference is displayed or the message "OFF CENTERLINE" is displayed. This message lets you know that a station/offset cannot be computed for the coordinates entered.

- **Read:** This command reads the instrument to gather coordinates for point projection.
- **Intersect:** This command will project the coordinates entered perpendicular, back to the centerline and enter these new coordinates into the Point Projection dialog. From there you can store or stakeout the intersect points.
- **Stake:** This command will allow you to stakeout the displayed coordinates (typically used to stakeout the intersect points).
- **Store:** Pressing Store after Read stores the offset coordinate. Store after Intersect is selected stores the coordinates for the intersect point on the centerline (perpendicular from the offset point). Store after entering coordinates or a point number for the offset point, without selecting Intersect, will simply store the offset point coordinates again as a new point number. Store is most often used to save the calculated intersect points to the coordinate file. Pressing Store will save an SP (store point) record in the raw file, and a note record will indicate that the point was calculated within Point Projection.





- **Computing Ranges of Point Offsets with Special Report:** A range of points can be entered leading to reporting of all stations and offsets to a selected horizontal alignment (centerline). In the example below, a centerline has 7 points shown at offset.

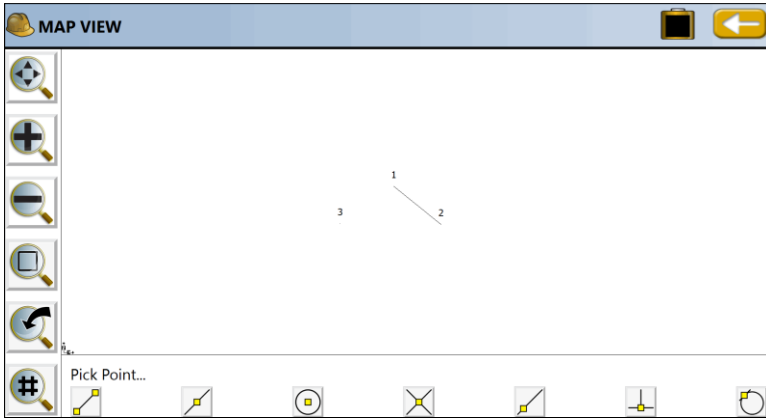

If point 1 is entered, you get the normal station and offset report. And if point 1 has an elevation, and "Use Vertical Alignment" is clicked on when selecting the alignments, you will get a cut and fill as shown:

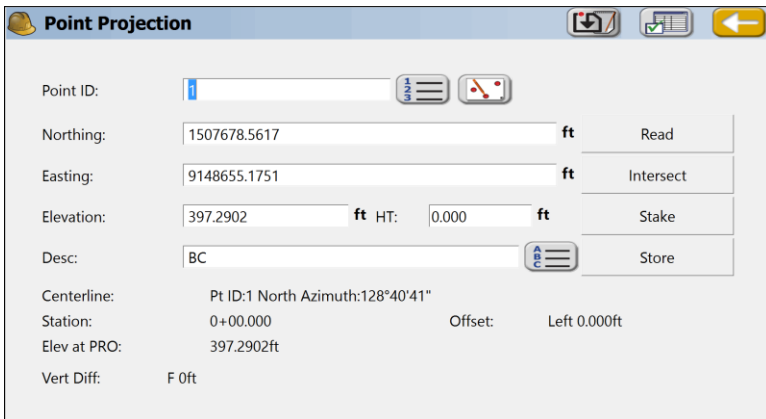



When entering a range of points, use normal range conventions (e.g. 1-6, or 1-7,10,14-16). You can present the range appearance by clicking the Settings icon at the top of the screen, just left of the back arrow. You can compare Survey to Design where if the field point is 841 and the profile vertical alignment is 840, it would be a Cut 1, or you can compare Design to Survey in which case that would be a Fill 1. Comparing Survey to Design is normal operation.

Settings

Include Header

Include Station, Offset, Elevation

Include Cut/Fill

Survey->Design

Include Point ID

Round Station to the Nearest

1

Offset Prefix: Left: L Right: R

Then click the report button to see the results for points 1 to 7, as output to a TXT file and viewed in Notepad.

#Station	Offset	Elevation	Cut	Fill	Point ID
0+41.304	,L 82.27	,841.839	,1.731	,	,
0+86.930	,L 82.20	,841.839	,2.400	,	,
1+31.460	,L 83.16	,840.449	,1.437	,	,
1+77.185	,L 84.28	,840.449	,1.644	,	,
2+22.791	,L 88.96	,840.598	,1.766	,	,
2+68.853	,L 87.43	,840.598	,1.501	,	,
2+09.384	,L 14.36	,838.172	,	,0.630	,Manhole



## 7.6 Station Store



**Station Store** is a pure calculation routine that will create points based on a station and offset from an alignment. The alignment may be defined as a centerline, a 3-point arc, an arc defined by a PC, Radius and PT, a selected polyline, or a sequence of points. The user may also assign an elevation to the calculated point. Station Store is useful for calculating right-of-way locations, which are typically defined as station and offset. Station Store might also be used to enter elevations of pipe culverts, for example, where inlets and outlets are located at distinct stations, offsets, and elevations. Then the two calculated points at the inlet and outlet can be used within Stakeout Line to stake any point along the culvert, with the cut/fill calculated. Although the command Stake Centerline, found within Stakeout Line/Arc, will directly stakeout a particular station and offset to a centerline, some users prefer to pre-calculate the station and offset and assign a point ID, then stake by point ID. Station Store permits this pre-calculation of points at any station and offset.

The very first screen within Station Store offers several methods of defining an alignment, similar to Stake Line/Arc.

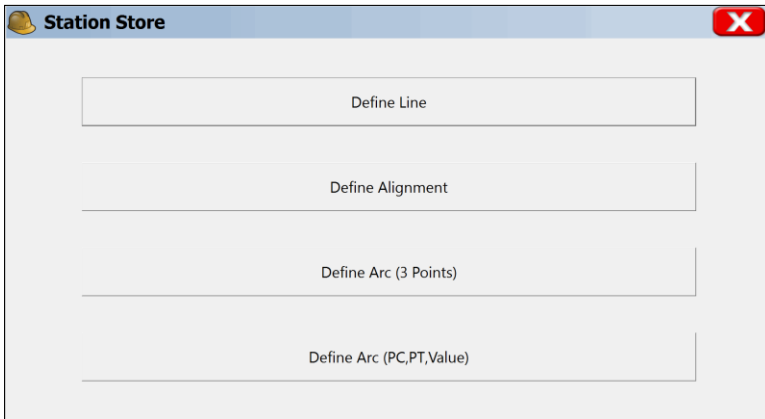



The following screen is where you enter the station, offset, and elevation to compute and store a point location.

**Station Store** Starting Sta: 0+00.000

Station:  ft

Interval:  ft

Offset:

Left  Right

Z:  ft  Override Design

Additional VOff:  ft

Segment (H): Tangent (V): Extrapolated

Desc: 1+00.000 R0.000ft

Pt ID:  Store

In this example, a right-of-way point on a metric-based horizontal alignment is calculated at 0+567.175, offset left 65.451 meters, and assigned point ID 9. Note that the program detects that point 9 is outside a spiral curve segment of the defined alignment.

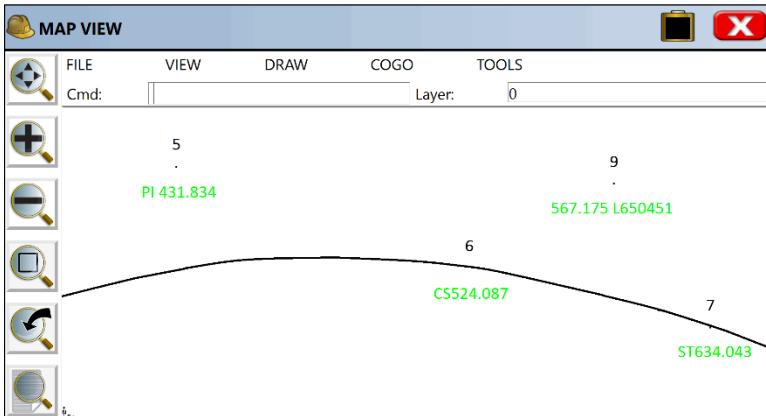



The description is fixed as the station and offset but can be edited using the command Keyboard Input or File, Points. The "Interval" option is not typically applied, unless Store Multiple is selected, in which case points will be stored sequentially at the entered offset from the starting station to the ending station as entered. In addition to calculating a station and offset perpendicular left and right, skewed pipes can be calculated by selecting the "skew back" or "skew ahead" options in the pull-down list where "offset" is the default. A zero skew pipe is perpendicular to the horizontal alignment. So, a "skew ahead" of 20 degrees would be 20 degrees "ahead" of the 90 degree offset, or 70 degrees to the right of the forward tangent. Here is an example where both ends of a pipe are calculated, with the resulting graphic shown below. Decimal places on the stationing are set under File, Job Settings, Format Tab, Station Display.

**Station Store**

Starting Sta: 0+00.000 End Sta: 0+14.142

Station: 3+48.195 ft Interval: 10 ft

Skew Bk: 78.21 27'15"00"

Left  Right

Z: 21.137 ft  Override Design Additional Voff: 0 ft

Segment (H): Tangent (V): Extrapolated

Desc: 3+48.195 L SkewBK 78.21@27'15"00"

3+48.195 L SkewBK 78.21@27'15"00"

Pt ID: 10 Store

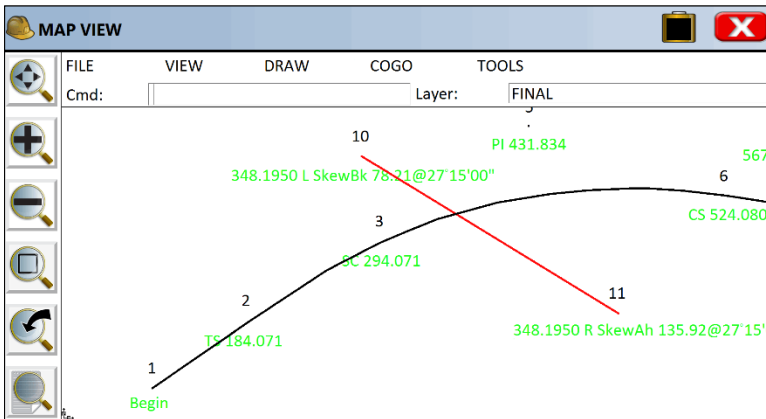



## 7.7 Transformation



This command allows you to translate, rotate, and/or scale points in the current job. Any point drawn on the map screen will be updated automatically in addition to updating the coordinates.



All three transformations can be performed individually or all at once if desired. You first fill out the options in one or more of the tabs (Translate, Rotate and Scale), and then you press Enter and obtain a second screen where you fill out the range of points to transform.

**Linear Transformation** ✓ ✕

**Translate** | Rotate | Scale | Align



Delta:

N: 0.0000 ft E: 0.0000 ft Elv: 0.0000 ft

Original Pt ID:   

N:  ft

E:  ft Elv:  ft

Destination Pt ID:   

N:  ft

E:  ft Elv:  ft



## Translate

On the translate dialog, enter in the Delta North, Delta East, and the Delta Elevation. These values represent the change in the original coordinate values and the desired coordinate values. When complete, select the OK button on the dialog, or navigate to the ROTATE or SCALE Tabs for further data input.

The image displays two screenshots of the 'Linear Transformation' dialog box. The top screenshot shows the 'Translate' tab with the following fields:

- Delta: N: 0.2508 ft, E: -39.9992 ft, Elv: 0.0000 ft
- Original Pt ID: 2
- Destination Pt ID: 1
- Original coordinates: N: 1507663.5477 ft, E: 9148673.9304 ft, Elv: 397.2827 ft
- Destination coordinates: N: 1507663.7985 ft, E: 9148633.9312 ft, Elv: 397.2827 ft

The bottom screenshot shows the 'Points' and 'Linework' sections:

- Points: Highest Point ID: 4
- Range of Points: 1-4
- Add to Point IDs: (empty)
- Overwrite Existing Point IDs
- Use New Point IDs
- Store in New CRD File
- Linework: 0
- Automatic - All Layers
- Process Frozen Layers
- Manual - Select

The lower portion of the screen shows an alternate method of defining a translation by comparing an original point to a destination point. Data entered here, as point ID or directly entered northing, easting and elevation, will lead to computation and display of the delta N, delta E and delta Z in the upper portion of the screen.

- **Range of Points:** Enter the range of points to translate. Ranges can be entered in the following format: 1-20,32,40-45, etc..
- **Add to Point Numbers:** Enter a number to add to existing point numbers when creating new point numbers. This option is not available when overwriting your existing point numbers. See example below under Use New Point Numbers.



- **Overwrite Existing Point Numbers:** Overwrites the existing point coordinate data with the new coordinate data.
- **Use New Point Numbers:** Uses new point numbers for the new coordinate positions while keeping the existing point numbers and coordinate data. Each time a point is to be overwritten, you will be prompted whether to overwrite or use a new point number. This method is only recommended when you are transforming very few points and wish to give each a specific point number assignment.
- **Store in New CRD File:** This option writes the transformed points to a new CRD file while keeping the existing point numbers and coordinate data. You may also choose to input a number for Add to Point Numbers, but this is not required.
- **Linework:** This option allows for linework transformation. When this option is selected, options below become accessible.
- **Automatic – All Layers:** This allows for the user to select all linework as part of the linear transformation.
- **Process Frozen Layers:** This option allows the user to select Frozen Layers to either be included or excluded from the linear transformation.
- **Manual – Select:** This option allows the user to manually select linework to be included in the linear transformation routine.

When **OK** is pressed, a second screen appears which controls the range of points to be translated.

Assuming you have 55 points in your file, you could "preserve" these 55 points by adding 100 to the point numbers and saving the transformed points as 101 through 155. If you choose **Overwrite Existing Point IDs**, the Add to Point Numbers option is not available. If you choose **Use New Point Numbers**, then you will be prompted to enter a new point number for each existing point to be overwritten (recommended only when you are overwriting a few points). You can even store the transformed points in a completely new CRD file by selecting **Store in New CRD File**.

**Raising and Lowering Elevations:** Users often ask, "How do I raise or lower elevations on a range of points?" The answer is the **Translate** option in the **Transformation** routine. To adjust elevation only, enter only the delta elevation (leave Northing and Easting at 0 translation).





## Rotate

The ROTATE tab is used to rotate points in a coordinate file. Enter the desired degree of rotation into the degree of rotation data field. Specify the rotation base point. This can be accomplished by either entering the point number of the desired point manually, or by selecting the point using the **List** or **Map** icon. You may also enter in coordinates for the rotation point if the point is not present in the coordinate file. Lastly, you can define the rotation by referencing two points (such as "From 1, To 2"), then specifying the desired new bearing for these points. Even the new bearing itself can be computed from two points used as a reference.

The second screen appears, which allows you to set the range of points to transform and choose how to store the newly calculated points. For all rotations, the rotation value is written into the RW5 file as dd.mmss (the current angle format).

## Scale

The scale tab is used to scale the points in a coordinate file. The northing, easting, and optionally, the elevation, are multiplied by the specified scale factor. Enter the desired scale factor in the scale factor field. Select the base point by entering the point number of the desired point manually, or by selecting the point using the **List** or **Map** icon. You may also enter coordinates for the scale base point if the base point for scaling is not present in the coordinate file. The coordinate of the base point will remain unchanged. All other points will scale. If the **Ignore Elevations** toggle is enabled, then only the northing and easting values are scaled. Note that you can scale your points from base coordinate 0,0,0 by entering a scale factor and answering Yes to the warning screen.

## Raw Data Records

The transformation raw data records are expressed as one string per command with the values separated by spaces. These records will be recorded to the raw data file for processing purposes so that all Carlson processors will recognize the records and perform the transformation during re-processing.

- **TRANSLATE:** Range Dx Dy Dz Process\_Zero\_Z
- **ROTATE:** Range Angle Base\_Y Base\_X
- **SCALE:** Range Scale Base\_Y Base\_X Use\_Z
- **ALIGN:** Range From1 To1 From2 To2

Example:

```
CC,Translate,8-9 200 50 0 0
CC,Rotate,7 33.1234 79613.662 15619.725
CC,Scale,7 1.5 79613.662 15619.725
CC,Align,8-9 8 6 9 7
```



## 7.8 Calculator



This command eliminates the need to carry a separate calculator in the field. The calculator can be used to do scientific computations, standard calculations, conversions, triangle calculations, including angles, and curve calculations.

### Standard Calculator

Most basic calculations can be performed using this tab in the calculator. Memory functions are also available.

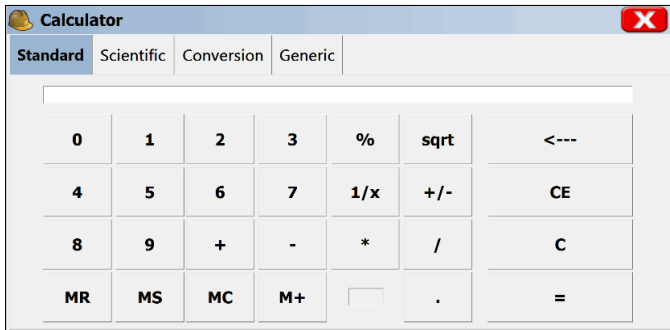

### Scientific Calculator

Values can be entered on the X register by typing on the keypad. The values can be rolled up and down with the up and down - arrow keys and the Roll and RollD buttons on the screen. The Enter key finishes the entry of a number and pushes the stack. The C on the touch screen clears an entry. Additional functions on the screen can be obtained through touching the scroll [ $\leftarrow$ ] and [ $\rightarrow$ ] area of the screen.

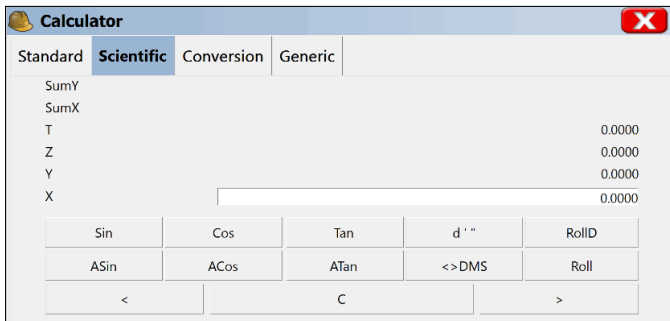



## Conversion Calculator

Conversion values can be entered for various unit types and scenarios.

- **M to Ft:** This option provides for conversion between many units. Enter a value in any field and press Enter to find the conversion value.

**Calculator** [Close]

Standard | Scientific | **Conversion** | Generic

M-Ft     Deg     SD-HD     LLH-Grid     Az-Br

> Feet    Meters

215.35    65.638811

> Int'l Feet

215.350431

Solve

- **Degree:** This option allows you to convert to/from Degrees, Decimal Degrees, and Mils (6400). Enter a value in any field and press Enter to find the conversion value.

**Calculator** [Close]

Standard | Scientific | **Conversion** | Generic

M-Ft     Deg     SD-HD     LLH-Grid     Az-Br

DD.MMSS    Gons/Grads(400)

33°22'11"    37.0774691358

Decimal Degrees    Mils(6400)

33.3697222222    593.2395061728

Solve



- **Slope Distance to Horizontal Distance:** This option allows you to convert slope distances with zenith angles to horizontal distances and vertical differences, and vice versa. See figure.

**Calculator** [Close]

Standard | Scientific | **Conversion** | Generic

M-Ft     Deg     SD-HD     LLH-Grid     Az-Br

Slope Distance:

Zenith Angle:

Solve SD/ZA

Horizontal Distance:

Vertical Difference:

Solve HD/VD

**LLH - Grid:** This option allows you to convert from Latitude/Longitude to grid system coordinates and vice versa. If you are configured for U.S. State Plane Coordinates, the routine conveniently displays your zone, and you can even change zones for quick calculations without altering your GPS zone settings in Job Settings. Otherwise, the calculation is based on your Job Settings GPS Zone. To solve for northing and easting, fill in the latitude and longitude and press Solve N/E. To solve for latitude and longitude, fill in the northing and easting and press Solve Lat/Long. You can set the state plane zone at the bottom of this dialog.

**Calculator** [Close]

Standard | Scientific | **Conversion** | Generic

M-Ft     Deg     SD-HD     LLH-Grid     Az-Br

Lat DMS:  N  S     N     S

Lon DMS:  W  E     W     E

Hgt:     Pt ID:

Solve Lat/Lon    Save    Hgt:     Solve N/E

Apply Localization     Apply Geoid

After completing a conversion, you may enter a point ID and press **Save** to save the coordinates to the current job. You can also change the type of transformation or zone system used. If you don't want NAD 83 (primarily used in the U.S.) you can go to **Job Settings, GPS** and change the Transformation type. For example, you could change



the Transformation to UTM or NTF-France. Then, back in Calculator, your coordinate to Lat/Long calculation would be based on the configured transformation. Note that when converting Grid System Coordinates to WGS84 coordinates and going WGS84 to Grid, the geoid separate file (if any) is applied to the calculation.

**Az-Br:** This does a straight, simple calculation converting azimuths to bearings. A prime example, shown below, would be converting an azimuth of 119.2547.

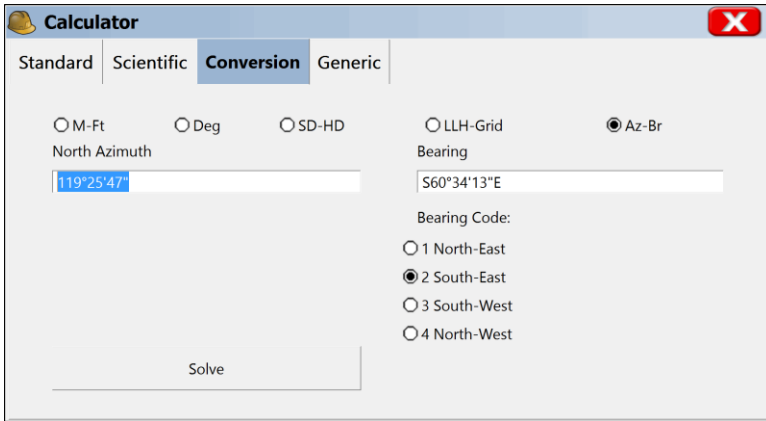

### Generic Calculations

There are two types of calculations that can be performed from the Generic tab. Click the large, square icons to go to the Triangle or Curve calculator.

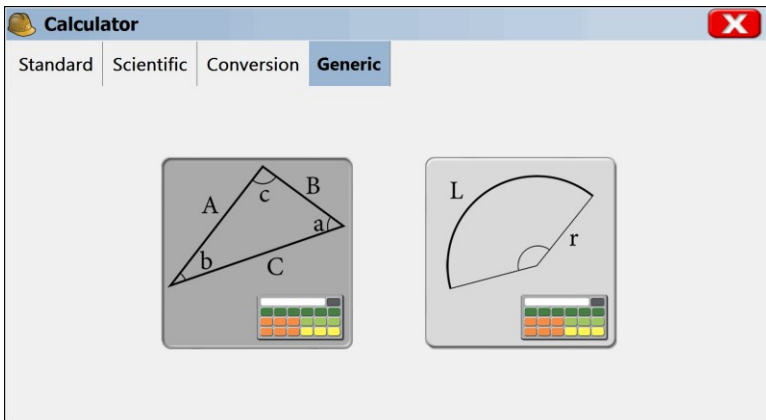



## Triangle Calculator

The figure below shows the Triangle calculator. The top of the dialog box indicates the mode of calculation. To change the mode, simply use the pull-down and to select the desired mode.

- Side-Side-Side
- Angle-Side-Angle
- Side-Angle-Angle
- Side-Angle-Side
- Side-Side-Angle

**Triangle calculator**

Side-Side-Side

Side(A):  
21.1200

Side(B):  
15.8400

Side(C):  
26.4000

Select 3 points from:

Clear

Results

View Triangle

After choosing a mode, simply apply the values to the appropriate blank and hit Solve. Points from your current job can be selected to fill out the blanks as well. The points can be selected from the screen or from the point list by picking the appropriate button icon. After the calculations have been performed, you will see the Clear, Results, and View Triangle buttons. Clear will clear the entry fields. Results will show the results dialog again. View Triangle will draw the triangle on the screen connecting the points chosen for the calculation. The triangle calculator, using 3 points, is a convenient way to calculate the interior angle between 3 points. For example, if you were setup on 1, backsighting 10, and turned a 90 degree angle to 21, then the triangle defined by 10 to 21 would indicate a 90 degree angle at point 1.

**Triangle Solution**

Side(A): 21.1200  
Side(B): 15.8400  
Side(C): 26.4000  
Angle(a): 53°07'48.37"  
Angle(b): 36°52'11.63"  
Angle(c): 90°00'00"  
15.5400SQ. METERS



## Curve Calculator

The figure below shows the Curve calculator. Simply use the pull-down at the upper left to select the desired method of curve calculation.

- Radius-Delta Angle
- Radius-Chord Length
- Radius-Arc Length
- De.g. of Crv.-Delta Angle
- De.g. of Crv.-Chord Length
- De.g. of Crv.-Arc Length
- Delta Angle-Chord Length
- Delta Angle-Arc Length
- Chord Length-Arc Length

The screenshot shows the 'Curve calculator' window. On the left, there is a pull-down menu currently set to 'Radius-Chord'. Below it are input fields for 'Radius(R):' with the value '500.2100' and 'Chord Length(C):' with the value '924.2500'. There are 'Clear' and 'Solve' buttons. On the right, under 'Type Degree of Curve:', the 'Roadway' radio button is selected. A diagram of a circular curve is shown with labels: 'L' for arc length, 'C' for chord length, 'R' for radius, 'a' for delta angle, and points 'P1', 'P2', and 'P3'. At the bottom, there are three icons: a list, a red circle with a dot, and a triangle with a dot.

The type of curve can be toggled between roadway and railroad. Values can be entered into the blanks by keyboard entry, by selecting points from the current job, from a point list, from the screen, or by selecting an arc drawn on the screen. Once the values are entered, the results are displayed on the screen. The results can be viewed by selecting the **Results** button. The curve can be viewed on the screen by selecting the **View Curve** button.

The screenshot shows the 'Curve Solution' window. It features the same curve diagram as the calculator. Below the diagram, the following data is displayed: 'Type Degree of Curve: Roadway', 'Radius(R): 500.2100', 'Delta Angle(a): 134°59'41.08"', 'Arc Length(L): 1178.5462', 'Chord Length(C): 924.2500', 'Tangent: 1207.4571', and 'External: 806.7570'.



## 7.9 Manual Traverse



This command allows for manual entry of angles and distances and calculates sideshots or traverses from a known occupied point. If the direction is defined by a bearing or azimuth, a backsight point is not required. If the direction is defined by angle left or right or a deflection angle left or right, then a backsight point is required.

**Manual Traverse** is actually a **first** option of three for manual traverse and sideshot entry.

A **second** option is to go to the Map screen, and at the command line (Cmd:) enter:

- **"I"** for **Inverse**, to inverse to an occupied point, or from backsight point to occupied point,  
-Then-
- **"T"** for **Traverse** or
- **"S"** for **Sideshot**, using angle codes 1-NE, 2-SE, 3-SW, 4-NW, 5-AZ, 6-AL, 7-AR following the prompting for angle and distance entry.

This style works strictly off the keyboard and does not require any screen tapping to switch from traverse to sideshot to inverse. The points plot on the screen as you go.

A **third** option for traverse and sideshot entry is to set the equipment type to Manual Total Station and enter the traverse and sideshot data within the Store Points command.

All three of the methods will store data to the raw survey file for re-processing and will allow entry of instrument heights and target heights. In the Map screen, **Traverse Defaults** (TD) will turn instrument and target height prompting on and off. All three methods allow for zenith angle prompting as an option.

The command centers around one main entry screen. You must enter an occupied point for traversing. You must also enter a target point number to calculate.

The screenshot shows the 'Manual Traverse' software interface. It features a title bar with a yellow icon and a back arrow. The main area contains several input fields and buttons:

- Occupied Pt ID:** 1 BC
- Backsight Pt ID:** (empty)
- Target Pt ID:** 5 Desc: (empty)
- El/Off  TR Mode
- Bearing SE:** S45°00'00"E SE
- Slope (%):** 2.64% SP
- Horz Dist:** 4.2824 HD
- Labels:** Hdst, Sdst, sNo, hDno
- Buttons:** Calculate, Store





- **Horizontal Angle:** You must select a horizontal angle method. Options here are AR (angle right), NE, SE, SW, NW, AZ, SAZ (south azimuth), AL (angle left), deflection left, and deflection right. If a bearing or azimuth is selected for traversing, the backsight point number will become inactive. Only an occupied point is required to traverse forward by bearing or azimuth. All other turned-angle methods will require a backsight point number. The stored descriptions for the occupied point and backsight point will display as shown above (TRV MAG and TRV N in this case). Occupied points and backsight points can be selected from the list or the map using the appropriate icons. You can also enter point-defined angles, as in 6,7 for the direction from 6 to 7, or 6,7+90 for 90 degrees to the right of the direction of 6 to 7.
- **Elevation/Vertical Angle Method:** There are many ways to calculate a vertical differential between the occupied point and target point. The most common method is zenith angle (ZE). Manual Traverse also offers vertical angle, delta Z (elevation difference), slope by percent (SP), slope by ratio (SR), and known elevation (Z). To get the slope from point 6 to point 7, switch to SP mode and enter 6,7 for the slope.
- **Distance Method:** There are four methods of distance entry: **Horizontal Distance** (in which case the elevation line is inactive), **Slope Distance**; **Slope Distance, No Elevation**; and **Horizontal Distance, No Elevation**. Both Slope Distance methods will prompt for vertical angle/zenith angle, etc., but Slope Distance, No Elevation will calculate a zero-elevation for the target point number and will reduce the slope distance by the effect of the vertical angle/zenith angle. You can also enter the distance in the form of 6,7 for the distance from 6 to 7, or as 6,7/2 as half the distance from 6 to 7. Note that if you wanted to interpolate a point 12 midway between 6 and 7, you can use all 3 edit boxes to accomplish this. The azimuth or bearing could be entered as 6,7. The slope would be entered as 6,7, and the distance would be entered as 6,7/2. So if point 6 is elevation 100 and point 7 is elevation 101, point 12 will have elevation 100.5.

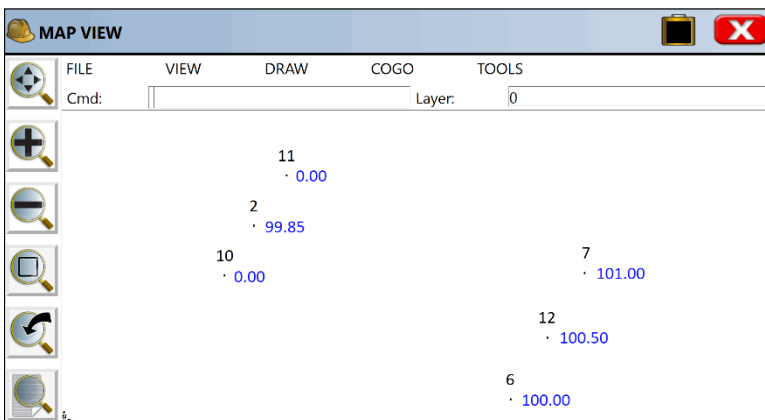



- **Enter Elevation:** If **Enter Elevation** is enabled, a check screen is activated to display the calculated elevation. From here you can override the calculated elevation with a new elevation. This option is useful in combination with Horizontal Distance for calculating points at a known distance and fixed elevation.
- **TR Mode:** Enabling **Traverse Mode** will cause the routine to “traverse up” to the target point number, so that the new occupied point number will automatically change to the last target point number, and the new backsight will change to the last occupied point. You can always manually change the fields for occupied point and backsight point and “force” a traverse, but enabling Traverse Mode will update these fields automatically, so that you immediately “move up”, and are awaiting the next angle and distance entries. With TR Mode disabled, **Manual Traverse** defaults to sideshot mode.

When you are entering in the horizontal angle, distance, or elevation/vertical angle information, the program displays the current mode as an extra confirmation at the bottom of the screen. Hitting **Enter** from the last entry line, or tapping **Calculate**, or entering a **C** for calculate, will solve for the coordinates and display them at the bottom of the screen. Hitting **Enter** again, tapping **Store**, or entering **S** will store the points. Before storing, you can also tap the **Map** icon to see the location of the calculated point, in reference to the occupied point and backsight point.

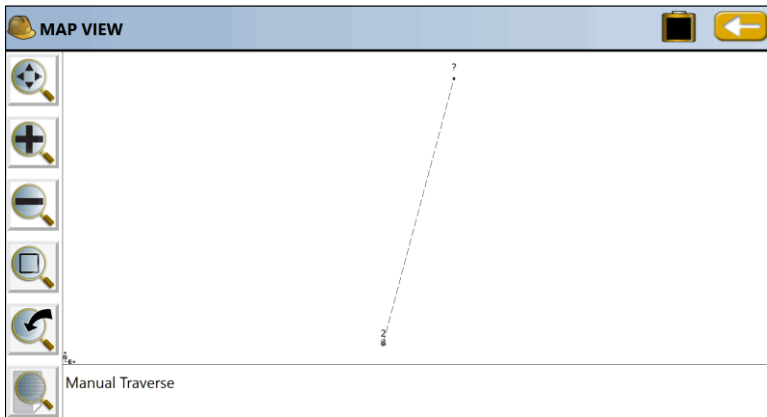

Click **Back** to return. You always have the option to enter new angle and distance information, Calculate, check the Map, then Store, as desired. **Point in Direction** offers the flexibility to check point locations graphically prior to storing.



- **EI/Off:** If EI/Off is clicked on for Elevation mode, a “check screen” is activated that allows you to see the calculated elevation and potentially override it with a new elevation. This option is useful in combination with **Horizontal Distance** for calculating points at a known distance and fixed elevation. This screen also allows you to offset the point perpendicular to the computed traverse i.e. Enter positive for right and negative for left.

**Manual Traverse**

Occupancy Pt ID: 2 BC

Backsight Pt ID:

Target Pt ID: 5 Desc:

EI/Off  TR Mode

Bearing NE: N15°00'00"E NE

Zenith Angle: 90°00'00" ZE

Horz Dist: 25.0000 HD

N:1507687.6959 E:9148680.4008 Z:397.2827

Calculate **Store**

**Elevation/Offset**

Pt ID: 5

Northing: 1507687.6959

Easting: 9148680.4008

Offset: 0.0000

Elevation: 397.2827ft

Set El to: 397.2827 ft

Desc:



## 7.10 Point Average



**Standard Point Average:** The standard **Point Average** command works especially well in conjunction with the Auto Store by Interval command found in the Survey menu. If you set the Auto Store by Interval command to storing by Time rather than Distance, you can also set the maximum number of points to store (e.g. 100), and in this way, store a specified number of readings at any desired time interval. Stored points will auto-increment from the entered Starting Pt ID. If the "Record Max Number of Points" is not clicked On, then storing will occur until the user ends the process by clicking the Red Stop icon or the Red X in the subsequent screen. The Auto Store by Interval dialog is shown below:

**Auto Store by Interval** ✓ ✗

Distance X/Y: 10.0000 ft  
Z: 10.0000 ft

Time 10 s

Starting Pt ID: 301

Description: AVG

Record Max Number of Points: 100



**Point Average** is a processing command useful in obtaining both the average value of a set of readings as well as estimates of the variation of the data. If 15 points are measured from 9 to 23, the calculation of the average is shown below:

On/Off	Point ID	Northing	Easting	Elevation	Description	H Res	V Res	H	V	Point ID
<input checked="" type="checkbox"/>	9	1507663.44	9148655.74	397.286	AVE	0.09	0.011	<input checked="" type="checkbox"/>	<input checked="" type="checkbox"/>	9
<input checked="" type="checkbox"/>	10	1507663.42	9148655.76	397.297	AVE	0.06	0.001	<input checked="" type="checkbox"/>	<input checked="" type="checkbox"/>	10
<input checked="" type="checkbox"/>	11	1507663.41	9148655.78	397.306	AVE	0.04	0.010	<input checked="" type="checkbox"/>	<input checked="" type="checkbox"/>	11
<input checked="" type="checkbox"/>	12	1507663.40	9148655.78	397.292	AVE	0.03	0.005	<input checked="" type="checkbox"/>	<input checked="" type="checkbox"/>	12

Average Coords:                      ft                      StdDev:                      ft

N: 1507663.3835ft                      N: 0.0252ft

E: 9148655.8067ft                      E: 0.0298ft

Z: 397.2967ft                              Z: 0.0103ft

Range of Pts: 9-23

On/Off                      Average

Individual points can be turned on and off for purposes of the calculation. The standard deviation is presented. The range of points is entered using the standard SurvPC convention of dash and comma separators. For example, to average points 401 to 410 as well as 415 and 420 to 425, the entry format would be 401-410,415,420-425. Additional points can be added using the "From List" and "From Map" icons. When new points are added or points are turned on or off, clicking Average initiates a fresh calculation. To store the averaged coordinate values as a point ID, click the "Store to Disk" icon at the top of the screen. Click the back arrow to return to the main COGO menu screen.

Store Point

Point ID: A300

Description: AVERAGED PT



**GNSS Analysis Point Averaging:** If under Job Settings, Options tab, "Apply GNSS Analysis" is turned on, then the Point Average methods and screen dialogs are completely changed within **Point Average**. This analysis approach deals with one Point ID (+ Description as an option) at a time and works if multiple measurements were taken on that Point ID, either as distinct Store Point exercises or as A for Average within Store Points. The method, however, is designed for a field procedure of distinct single point measurements using Store Point, storing the same Point ID (+ Description as an option), typically at intervals over a period of time, capturing different satellite configurations. By using this procedure, greater point positional certainty can be obtained through statistical analysis. The Store Points option of A for average can work similarly if a longer time interval between measurements is used, but the advantage of the individual Store Points approach is that the GNSS rover can be used for other work between returning to the same point to measure it again with the same point ID.

So, if you were mixing topo or data gathering work with key point, boundary point measurement, you could measure the key point, do 30 minutes of topo, measure the key point again, do another 30 minutes of topo, and repeat that procedure, accumulating multiple data on the same point ID for the key point, in preparation for "**GNSS Analysis Point Averaging**". If all of your work was "key" point measurement, you could simply sequence from one key point to another, returning to the same points over an extended time period. Then the GNSS Analysis method will calculate the measured points to greater certainty (as reported statistically), with blunder detection and blunder removal.

With GNSS Analysis, extensive testing has shown reliability of between 1 and 2 centimeters with multiple readings, but with statistical standard deviations of as little as 3 millimeters. Blunder detection is accomplished using the Chi Square Variance Test. The parameters and error estimates are hard coded in the preliminary release of this feature, based on thousands of point measurements. This trial, fixed parameter feature is provided with the caveat that most testing has been conducted with Topcon and Altus GNSS receivers, and for fixed antenna conditions involving low and secure antenna positions. The parameters for statistical analysis may not apply to your specific condition. These parameters will be converted to user-defined variables with suggested ranges for settings in subsequent releases based on reports from trial usage with a wider range of equipment.

**Preconditions to GNSS Analysis:** The following preconditions must be set for GNSS Analysis.

- The GNSS Receiver itself must offer the option to store GPS vectors and make this available to Carlson Software.
- **File, Job Settings, Options Tab, Apply "GNSSAnalysis" to average identical GPS Pts: IDs or IDS+Descs**
- **Both the CRD file AND the associated RW5 file of the same name must be on the same data directory:** If you just copied a CRD file to a PC without the associated RW5 file, GNSS Analysis will not work. The companion, same name



RW5 file must be present on the same directory. Plus, the data in the RW5 has to contain RMS values, DOP values and vector data, stored based on the following two preconditions.

- **File, Job Settings, Options Tab, Store GPS Accuracy in Raw File On.** This stores the HRMS, VRMS, PDOP and other DOP values necessary for the statistical analysis.
- **File, Job Settings, Options Tab, Store GPS Vectors in Raw File When Available On.** This stores the base to rover vector data necessary for the least squares calculations used.

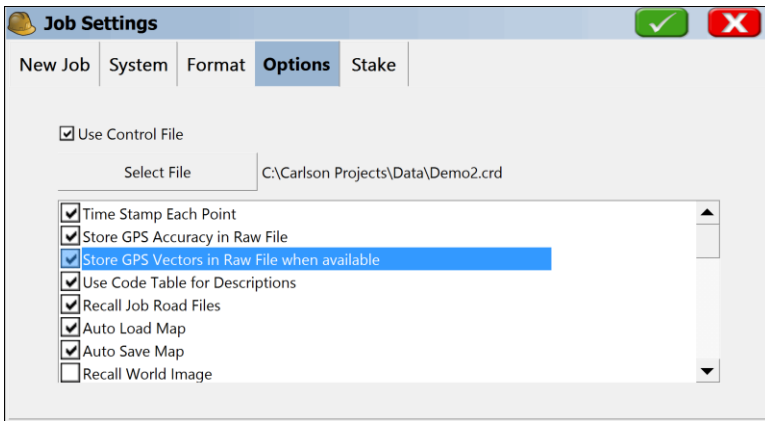

Because it is important to use the same Point ID, and because SurvPC will naturally increment points, it is also useful to turn on "Avg Same Point ID" in the Height/Description prompt screen as shown below:

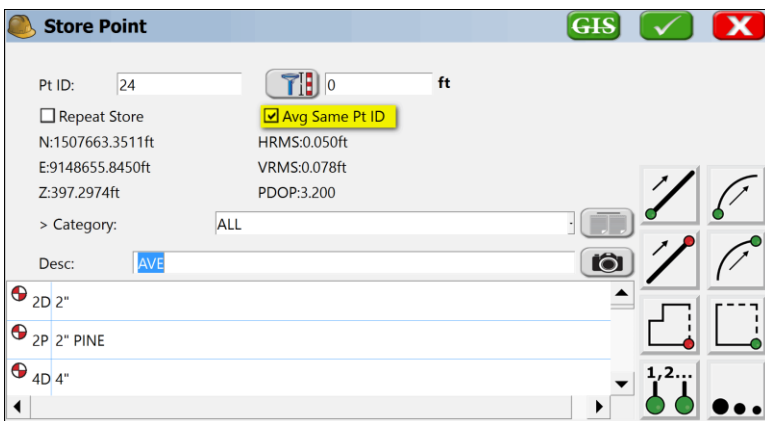

In this mode, if you measure a point for the second time, with the same ID, the program will assume you wish to overwrite it, will avoid the Point Protect screen and will



display the duplicated points in a list as shown below: And on the next measurement, after two appear in the list, the auto-increment is disabled and the program will remain on the same Point ID until you enter a new Point ID to measure. In this dialog, the point you choose to store can be averaged, with any individual point turned on or off in the left column. Click the Store Icon to store the point. Otherwise, the last point measured will be stored. This Point Average screen shown below left appears within the command Store Points itself with the option "Avg Same Point ID" on, as above. The screen shown below right appears if GNSS Analysis is on, Store GPS vectors is on and Store GPS Accuracy in Raw File in on. So the Store Points screen itself shows, in effect, the same dialogs as appear in Point Average, whenever "Avg Same Pt ID" is on. In that sense, the Point Average command is a way to recall measurements and do point averaging later, after you take field measurements. Conducting the averaging by standard and advanced "GNSSAnalysis" methods can occur while in Store Points with "Avg Same Pt ID" on or later by going to Point Average. Observations appear as 0 in upper right of dialog, until the minimum of 3 raw measurements for calculation purposes are obtained. Clicking Enter proceeds to the next measurement, equivalent to tapping the Green Check. So when repeating point IDs and remeasuring points, with Hgt/Description Prompt On, you can take measurements using GNSS Analysis with Enter for the measurement, Enter for the Hgt/Description Prompt, Enter for the Analysis review. With Hgt/Description Prompt Off in Configuration, each measurement would be 2 Enters.

On/Off	Point ID	Northing	Easting
	7	418343.5570	1779731.3865
	7	418343.5494	1779731.3967
	7	418343.5135	1779731.4166

Average Coords: **ft**    StdDev: **ft**  
N: 418343.5487    N: 0.0160  
E: 1779731.3929    E: 0.0113  
Z: 398.0860        0.0080

Pt ID	Northing	Easting	Elevation	Obs
1	418323.555	1779719.974	397.669	3

GPS+GLO	Blunder H	Chi-sq	H	Blunder V
6-0	0.316	357.295	<input checked="" type="checkbox"/>	-0.395
12-0	0.515	1012.470	<input checked="" type="checkbox"/>	0.737

Pt ID: 1    
 Ant. Freehand **Apriori:1.0**

Whether working from within Store Points or within the Cogo Menu, Point Average option, with GNSS Analysis on, AND with both vectors on, leads to analysis options as shown below:





Pt ID	Northing	Easting	Elevation	Obs
1	418323.555	1779719.974	397.669	3

GPS+GLO	Blunder H	Chi-sq	H	Blunder V
6-0	0.316	357.295	<input checked="" type="checkbox"/>	-0.395
12-0	0.515	1012.470	<input checked="" type="checkbox"/>	0.737

Pt ID: 1  Ant. Freehand **Apriori:1.0**

Easting	Elevation	Obs	StdDev H	StdDev V
1779719.751	397.399	2	0.022	0.025

GPS+GLO	Blunder H	Chi-sq	H	Blunder V	C
6-0	0.156	10.180	<input checked="" type="checkbox"/>	0.000	0.0
12-0	-0.476	0.000	<input type="checkbox"/>	-0.605	0.0

Pt ID: 1  Ant. Freehand **Apriori:1.0**



The program defaults to the display above right, by auto-running the blunder removal until  $H=0$  and  $V=0$  in terms of potential blunders. By clicking Reset, the "original" blunder status of all observations can be viewed. This example has only 3 field measurements, and when the 3rd measurement is removed, the remaining two observations pass the statistical analysis parameters. After clicking Reset, you can click Run to allow the program to automatically remove blunders, distinctly in the H and V columns, to obtain the maximum remaining number of measurements that pass the statistical test. With Chi-Square set to approximately 23, the program seeks to get the maximum F test value for the x,y (H) calculation around 10 or less and the maximum Q value for the Z (V) under 1.

If you don't use "Run", you can allow the program to present the highest contributor to errors and then remove these one at a time. In this way, you are rejecting the single observation with the largest contribution to the sum of the squares (standardized residual). Repeat until all observations that qualify for rejection are removed. In the report, the External Reliability is the maximum point deformation, or the maximum effect of a theoretical undetected blunder on the final computed coordinate. The calculations use the covariance information found in the data accuracy estimates of the GNSS receivers. A least squares calculation is used to find the best center point.

Although designed for 5, 10 or more same points readings, here is an example of 3 field measurements and how the blunder detection works when identified and removed manually:

Pt ID	Northing	Easting	Elevation	Obs
1	418323.555	1779719.974	397.669	3

Blunder H	Chi-sq	H	Blunder V	Q	V
0.316	357.295	<input checked="" type="checkbox"/>	-0.395	15.008	<input checked="" type="checkbox"/>
0.515	1012.470	<input checked="" type="checkbox"/>	0.737	42.031	<input checked="" type="checkbox"/>

Pt ID: 1  
 Ant. Freehand **Apriori:1.0**

Horizontal Blunders:

CHI-Square: 23.0259 Total: 3  
2 Degrees of freedom Max at Obs: 3  
Max F val: 1012.47 Err. level: 0.001%  
Nabla: 0.515 Significance: 99.999%

Vertical Blunders:

**Most Significant Steps to eliminate them: 2**  
QN Distrib.: 4.4172 Total: 3  
1 Degree of freedom Max at Obs: 3  
Max Q val: 42.031 Err. level: 0.001%  
Nabla: 0.737 Significance: 99.999%

Start by entering the Point ID in the lower left of the dialog to study. Press Enter after selecting the point for the data to appear. The "worst" blunder is identified by highlighting to the left of the H or V column. So, in this case, click of the V to the right of the highlight. Prior to doing so, if you click the Report icon (highlighted with red circle), you see the Report at right which shows the high F Value for the horizontal component and also high Q value for the vertical component. The process of removing blunders will reduce these values to acceptable levels (also accomplished automatically by tapping "Run"). So, after removal of the first blunder (V), on the third observation, the next worst blunder appears below, which is the (H) on the same 3rd reading. Note that when one blunder on the same reading is already identified, the next blunder on that reading is identified by reverse coloring (here white, not dark):



Pt ID	Northing	Easting	Elevation	Obs
1	418323.637	1779719.965	397.148	3

PS+GLO	Blunder H	Chi-sq	H	Blunder V
6-0	0.387	406.657	<input checked="" type="checkbox"/>	0.471
12-0	0.515	1012.470	<input checked="" type="checkbox"/>	0.737

Pt ID: 1  
 Ant. Freehand **Apriori:1.0** Reset Run

Horizontal Blunders:  
**Most Significant Steps to eliminate them: 1**  
CHI-Square: 23.0259 Total: 3  
2 Degrees of freedom Max at Obs: 3  
Max F val: 1012.47 Err. level: 0.001%  
Nabla: 0.515 Significance: 99.999%

Vertical Blunders:  
QN Distrib.: 4.4172 Total: 2  
1 Degree of freedom Max at Obs: 2  
Max Q val: 13.999 Err. level: 0.001%  
Nabla: 0.471 Significance: 99.999%

Notice how the Q value came down after removing the first vertical reading. Next, remove the "reverse highlighted" (H) reading for the third observation, which in effect eliminates that third reading altogether:

Pt ID	Northing	Easting	Elevation	Obs
1	418323.328	1779719.735	397.348	2

Chi-sq	H	Blunder V	Q	V	Date	Time
0.180	<input checked="" type="checkbox"/>	-0.026	6.011	<input checked="" type="checkbox"/>	13/27/02	18:52
0.180	<input checked="" type="checkbox"/>	0.026	6.011	<input checked="" type="checkbox"/>	13/27/02	18:56

Pt ID: 1  
 Ant. Freehand **Apriori:1.0** Reset Run

Horizontal Blunders:  
CHI-Square: 23.0259 Total: 0  
2 Degrees of freedom Max at Obs: 2  
Max F val: 10.18 Err. level: 0.001%  
Nabla: 0.156 Significance: 99.999%

Vertical Blunders:  
**Most Significant Steps to eliminate them: 1**  
QN Distrib.: 4.4172 Total: 2  
1 Degree of freedom Max at Obs: 1  
Max Q val: 6.011 Err. level: 0.001%  
Nabla: -0.026 Significance: 99.999%

With the third observation entirely removed, the horizontal blunders are eliminated (now 0) and max F value is an acceptable 10.18. The vertical Q value is still at 6, and one more blunder has been identified that is "significant" enough that removal is necessary and recommended. This is the vertical reading on the first observation. Remove that to obtain the final result (use of observations 1 and 2 for horizontal, observation 2 only for vertical). Remember, remove to the right of the highlighted item (the H or V):



Pt ID	Northing	Easting	Elevation	Obs
1	418323.371	1779719.751	397.399	2

Blunder H	Chi-sq	H	Blunder V	Q	V	
0.156	10.180	<input checked="" type="checkbox"/>	-0.026	0.000	<input type="checkbox"/>	13,
0.156	10.180	<input checked="" type="checkbox"/>	0.000	0.000	<input checked="" type="checkbox"/>	13,

Pt ID: 1  
 Ant. Freehand **Apriori:1.0** Reset Run

Horizontal Blunders:  
CHI-Square: 23.0259 Total: 0  
2 Degrees of freedom Max at Obs: 2  
Max F val: 10.18 Err. level: 0.001%  
Nabla: 0.156 Significance: 99.999%

Vertical Blunders:  
QN Distrib.: 4.4172 Total: 0  
1 Degree of freedom Max at Obs: 2  
Max Q val: 0 Err. level: 0.001%  
Nabla: 0 Significance: 99.999%

Observation 1 was used for the H only, observation 2 for H and V and observation 3 was not used at all (those observations get a line drawn through as below). This same result is obtained by tapping "Reset". The next "worst" blunder is still highlighted, but there is no reason to continue the process--analysis parameters are satisfied.

Pt ID	Northing	Easting	Elevation	Obs
1	418323.371	1779719.751	397.399	2

Obs	Northing	Easting	Elevation	Stat
2	418323.407	1779719.758	397.373	FIXE
3	<del>418323.665</del>	<del>1779720.125</del>	<del>398.005</del>	<del>FIXE</del>

Pt ID: 1  
 Ant. Freehand **Apriori:1.0** Reset Run

Apriori: 1.000000  
CHI-Square: 23.025851  
QN Distrib.: 4.417173

The "X" in the lower left of the screen is a somewhat arbitrary designation category. If 3 or more observations are used and pass the analysis, the quality of the observations are ranked 1 through 4 as follows: 1=city center, 2=rural area, 3a=farm land, 3b=forest, 4=unproductive land. The calculation will "qualify" for one of these designations with sufficient observations. Clicking the Settings button shows the hardcoded Aprior, Chi-Square and QN Distribution values. These values were selected based on extensive testing with a variety of commercial GNSS equipment. The "Antenna Freehand" setting will impact the calculation. If the GNSS antenna is on a fixed tripod, that resets parameters for the least squares calculations in terms of expected errors. If "Antenna Freehand" is clicked on, errors from a potentially moving antenna will be higher.

Here is another example, collected in the field using A for Average within Store Points. Note how all 5 observations are used.



Pt ID	Northing	Easting	Elevation	Obs
101	7718782.174	703258.563	59.822	5

LO	Blunder H	Chi-sq	H	Blunder V	Q	V
	0.224	6.753	<input checked="" type="checkbox"/>	-0.021	0.355	<input checked="" type="checkbox"/>
	0.171	3.008	<input checked="" type="checkbox"/>	0.062	0.410	<input checked="" type="checkbox"/>

Pt ID:   Ant. Freehand **Apriori:1.0**

**Horizontal Blunders:**  
CHI-Square: 23.0259 Total: **0**  
2 Degrees of freedom Max at Obs: 1  
Max F val: 6.753 Err. level: 0.001%  
Nabla: 0.224 Significance: 99.999%

**Vertical Blunders:**  
QN Distrib.: 4.4172 Total: **0**  
1 Degree of freedom Max at Obs: 3  
Max Q val: 0.558 Err. level: 0.001%  
Nabla: 0.048 Significance: 99.999%

Shown below is the right-side presentation of the statistically averaged point, including external reliability values and data on the duration of the measurement (delay), which in this case was 13 minutes. Longer delay values are recommended to obtain different satellite constellation configurations.

StdDev H	StdDev V	ExReliab H	ExReliab V	Delay
0.050	0.051	0.200	-0.162	00:13:30

Obs	Northing	Easting	Elevation	Stat
4	7718782.094	703258.471	59.781	FIXE
5	7718782.102	703258.501	59.758	FIXE

Pt ID:   Ant. Freehand **Apriori:1.0**



## 8 Road

This chapter provides information on using the commands from the Road menu.

JOB:DEMO3		File	Equip	Survey	COGO	Road	
1	Centerline Editor				6	Draw Template	
2	Draw Centerline				7	Utilities	
3	Profile Editor				8	Store Sections	
4	Draw Profile				9	Stake Slope	
5	Template Editor				0	Stake Road	



## 8.1 Centerline Editor



This command allows you to enter new centerlines, as well as recall and edit existing centerline files. Centerline files in SurvPC are ASCII files with a .CL extension. When the routine is selected, a dialog will appear in which you can load existing centerlines or begin entry of new centerline information.

CL Element	Length(ft)	End Station(ft)
Line	127.6211	1+27.621
Curve	92.0000	2+19.621
Line	88.7062	3+08.327

-  **Clear:** This icon, at the top of the screen, clears out all information in the dialog in preparation for entering a new centerline. With no centerline file loaded or saved yet, the file name in the upper left is displayed as “None.”
- **Start Pt ID:** If the centerline starts on a point number that exists in your current coordinate (.crd) file, you can enter the point number here, and it will recall and display the starting coordinates. The point can also be selected from the list or map using the appropriate icons.
- **Start Station:** You must enter the starting station for the centerline. (“Station” is the same as the European term “Chainage.”) Many surveyors and engineers prefer not to start centerlines at station 0. If the job backs up or needs to start further back along the centerline, this method will leave you with negative stationing. There are three centerline “forms” as set in **Job Settings, Units**. A starting station of 1500 can be displayed as 1+500 (metric, US-style, showing whole kilometers left of the “+”), as 1500.000 (pure decimal chainage, common to Europe), and as 15+00 (feet, US-style, sometimes also used on metric roads in Canada), often referred to as “station 15 plus 00”. In all cases, you would enter it as 1500, but it would display in the correct format after pressing **Enter**. For example, you would see 1+500.0000 if configured to kilometers. The program will also accept use of the “+” in the entry of the station and will convert to the configured form after you press **Enter**.
- **Northing, Easting:** If the northing and easting are not recalled from a starting point number, you will need to enter the northing and easting for the start of the centerline. It is not necessary to enter the northing and easting if you use the Pick PL (pick polyline) option for defining a centerline, since the starting coordinates of the selected polyline are automatically used and would overwrite anything previously entered.



- **Load:** This command allows you to load an existing centerline for review or edit. SurvPC will check the integrity of the centerline file. This check will happen automatically and the user will have an opportunity to verify the data if errors are detected.
- **Edit:** Use this button to edit the highlighted element.
- **Delete:** Use this button to remove the highlighted element.
- **Add:** Returning to the starting dialog, you can add elements to get a centerline started. Typically, you will start with a line or tangent segment, but you can also start on a curve or spiral curve element. When you select **Add**, you get to choose which element to use. These options include:

Element to Add

Line

Curve

Spiral-Curve-Spiral

Spiral Only

- **Add (Line):** A tangent section of the alignment. This option allows you to enter a point ID or coordinates to define the end of the tangent, or enter the station, or distance and the direction. To force the element to be tangent to the previous element, toggle on the **Tangential to the previous elem** option. This will gray out the direction field and will compute the tangent direction and enter it for you.

Line(Tangent) Element

Start Pt ID: Sta: 3+08.327

Nor: 5125.9457 Eas: 5138.9099

End Pt ID: [ ] [ ]

End Station: Northing:

5+08.327 ft 5324.5174 ft

Length: Easting:

200.0000 ft 5162.7697 ft

North Azimuth: 6°51'05.96652"

Tangential to the previous elem.

- **Add (Curve):** A typical circular curve section of the alignment. The first element of the curve defines what the options for the second element can be (See Lists Below). The **RR** toggle allows the user to use Railroad definitions. The **Review** button allows you to verify the Tangent In and Tangent Out bearings or azimuths (depending on Job Settings, Format, Angle Display settings), as well as confirm PC and PT coordinates. For example, this allows you to verify computed Tangent Out bearings against paper plans, before continuing entry of new elements.





**Curve Element** ✓ ✕

PC Sta: 3+08.327  Left  Right

Radius >

Arc Length

R Pt ID:  Nor:  ft

Eas:  ft

PT Pt ID:  Nor:  ft

Eas:  ft

Tang to Previous Element

Chord North Azimuth:  PT Sta:  ft

6°51'05.96652"  RR Review

- **Add (Spiral-Curve-Spiral):** The Spiral-Curve-Spiral element is really just two implementations of Spiral Only (line-spiral-curve and curve-spiral-line). The advantage of Spiral-Curve-Spiral is that it completes three elements at once and is a fairly common application on high-speed highways. This routine also allows the user to define the spiral-curve-spiral using known points as long as the spiral in and spiral out lengths are entered first.

**From Points** ✓ ✕

Spiral In Length: 300.0000ft

Spiral Out Length: 300.0000ft

TS:	None	<input type="button" value="Get Coords"/>
SC:	None	<input type="button" value="Get Coords"/>
PI:	None	<input type="button" value="Get Coords"/>
CS:	None	<input type="button" value="Get Coords"/>
ST:	None	<input type="button" value="Get Coords"/>

- **Add (Spiral Only):** The Spiral Only element will handle a spiral between any line and arc segment (e.g. line-spiral-arc or arc-spiral-arc).



**Spiral-Only Element** ✓ ✗

Spiral-In Northing: 5125.9457ft  
Spiral-In Easting: 5138.9099ft  
Spiral-In Station: 3+08.327

Spiral Length:  ft

Spiral Direction:  Left  Right  
Element At Spiral Out:  Line  Curve

Curve Radius At Spiral Out:  ft

- **Pick PL:** This option is only visible if you Clear the dialog. With this option, you can pick a centerline from any screen polyline, including polylines with arcs. When you choose **Pick PL**, you are immediately presented with the graphic screen, where you can pan by dragging across the screen, or zoom using the many zoom options. You can choose not to select a polyline (maybe there were none to select!) by pressing **OK** or **Enter**. When you select a polyline, it will highlight as a darkened polyline. After selecting a polyline and pressing **OK** or **Enter** you will see the polyline elements. Note that if you change the start station to 500, all the stationing for the polyline elements will change accordingly. This is also true regarding the starting northing and easting. If these are changed, all element coordinates will change accordingly, as can be verified using the **Edit** option.
- **EQ:** The EQ button allows you to enter station equations.

**Station Equations** ☰ ✓ ✗

Original	Station Back	Station Ahead
3+50.000	3+50.000	1+00.000

Sta Back:  ft Add

Sta Ahead:  ft Remove

- **Save As:** This saves the file. Enter a name.

*Note: You can create new points with Input-Edit Centerline. When you enter and save a centerline, it will prompt "Do you want to save centerline points?" You may answer Yes and save point IDs for the start, end, PI, PC, radius point, PT and any key spiral points found in the file. In the same way, a centerline that you load can be re-saved with new coordinate IDs assigned to all key points, as long as you make some change, like adding a point number to one of the Pt ID fields for a CL Element. If you answer Yes to Save Centerline Points, the dialog box below appears. If you have entered point IDs of your own choosing in the Input-Edit dialogs, use the upper option. The lower option will auto-number from the starting point ID without regard to any numbers you've entered but will respect and not overwrite used points in the file. Points are not stored to the centerline file itself, so after loading a stored centerline, no point IDs will appear.*



## 8.2 Draw Centerline



Draw Centerline will draw the selected centerline on the screen. All the zooming commands [Zoom In, Zoom Out, Zoom Window, Zoom Previous and Pan] are available to you in the **Draw Centerline** command. The program will automatically zoom to the extent of the centerline when drawn. If there are point numbers and polylines on the screen in that area, they will appear as well. This command only temporarily displays the centerline for reference and does not draw it on the screen as part of the dxf file associated with the job. To actually draw the centerline as a permanent feature (unless erased later), use **Map** (globe icon), **Tools, Centerline, CL** to **Polyline**.

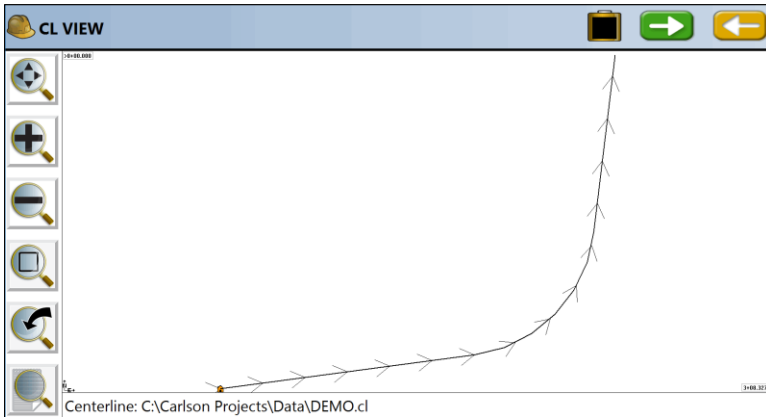



## 8.3 Profile Editor



Vertical alignments are typically referred to as profiles. The **Profile Editor** routine allows field entry of vertical alignment files for roads, sewers and other types of alignments. Vertical alignments can also be loaded and edited. In addition, high and low points can be calculated and the elevations of individual stations can be calculated. Vertical alignments, or profiles, are stored as files with a .PRO extension. In Carlson SurvPC, the station ranges of the profile and centerline do not need to match. As long as they have station ranges in common, any profile can be used with any centerline for all advanced Roding commands as well as Survey menu routines such as Offset Stakeout and Elevation Difference by Road Design files.

### Profile Entry

Profiles are extremely easy to enter. When the command is selected, if no prior profile has been entered, you will encounter the blank Input-Edit Profile dialog. You can also obtain a blank screen and start a new profile by tapping the Clear icon (eraser) at the top of the screen.

The screenshot shows the 'Input-Edit Profile' dialog box. At the top, it displays the file path 'C:\Carlson Projects\Data\DEMO.pro'. Below this is a table with four columns: 'PVI Station(ft)', 'PVI El(ft)', 'Slope %', and 'VC Len(ft)'. The table contains four rows of data. Below the table, there is a 'Check Sta' field with the value '107+25.5' and a unit 'ft'. To the right of this field are three checkboxes: 'Show Zeroes', 'Slope as Ratio', and 'Circular Curve'. At the bottom of the dialog, there are several buttons: 'Load', 'Add', 'EQ', 'Remove', 'High-Low', and 'Save As'.

PVI Station(ft)	PVI El(ft)	Slope %	VC Len(ft)
100+78.69	526.49	XXXXXXX	XXXXXXX
106+00	529.1	0.5007	600
114+29.25	520.8075	-1	600
122+52.25	541.3825	2.5	600

Check Sta: 107+25.5 ft

El: 527.4642ft

Show Zeroes  
 Slope as Ratio  
 Circular Curve

Buttons: Load, Add, EQ, Remove, High-Low, Save As

- **PVI Station:** PVI (Point of Vertical Intersection) is similar to a PI (Point of Intersection) for horizontal alignment. In some locations, the term VPI is used (Vertical Point of Intersection). You can start immediately by typing in the starting station under the PVI column. For our highway example, the starting station is 10078.69.
- **PVI Elevation:** The starting elevation is 526.49. So simply press **Enter** and move from the PVI column to the PVI El column and enter 526.49. Pressing **Enter** again moves onto the next PVI field, where you can enter 10600 for the next station, then 529.10 for the next PVI elevation.
- **Slope %:** Once a second station and elevation are entered, the program will calculate the percent slope. Alternately, if you enter under the Slope % before entering the PVI elevation, then the program will calculate the PVI elevation. The



slope column is a nice check against bad entries in the PVI elevation column. In other words, you often expect even slopes, and you can check the computed slopes against the plans. Slopes can be entered as **Slope as Ratio** when that option is clicked, and if you click "Show Zeroes", the dialog will show a consistent number of decimals (typically 4) in all columns, causing the data and decimal places to line up vertically.

- **VC Lng:** Vertical Curve Length: For road jobs, you can enter the vertical curve length in this column. This is the total length of the vertical curve. If the length entered is 600, this means that the vertical alignment transitions through a curve (parabola) beginning 300 units (feet or meters) before the PVI and ending 300 units after the PVI. If a vertical curve is uneven, that is, it transitions from, say, 400 feet before the PVI to 200 feet after the PVI, then the curve must be entered using the form 400-200 (the before and after distances separated by a dash). SurvPC assumes all vertical curves are parabolas (U.S. road industry standard). However, you can tap the **Circular Curve** option when that applies. For sewer and water line alignments, there is typically no vertical curve transition, so this column can be left blank, or 0s can be entered for vertical curve lengths.
- **Check Station:** When the profile for a highway job has been entered in a dialog, you can also enter a value to Check Stations. This feature is at the bottom of the dialog. This will check the grades at any desired station. When entering stations, you may include the "+" that is often used, as in 12+680.5 (English) and 126+80.5 (metric).
- **Load:** The Load command presents a list of all previously stored profiles. When one is selected, it displays the profile information in the dialog. To load a stored file, you simply enter the name (for example, "Demo"). No file extension is necessary. Alternatively, you can select a name from the list and accept it by pressing **OK** or **Enter**.
- **Add:** The Add button will create a new row at the cursor position with 0 entries (with the exception of slope, which will compute based on the 0 entries). If, for example, you touch line 2, where we have station 106+00, the **Add** command will allow you to insert a new row above. This would be necessary if you needed to start the profile at an earlier station. To add to the end of your profile, just click the down - arrow key at the right until a blank line becomes available and make your new entries.



**Input-Edit Profile**

C:\Carlson Projects\Data\DEMO.pro

PVI Station(ft)	PVI El(ft)	Slope %	VC Len(ft)
100+78.69	526.49	XXXXXXX	XXXXXXX
0+00	0	-5.2238	0
106+00	529.1	4.9915	600
114+29.25	520.8075	-1	600

Check Sta: 107+25.5 ft  Show Zeroes  
 Slope as Ratio  
El:  Circular Curve

Load Add EQ Remove High-Low Save As

- EQ: This button allows you to select the Centerline. There is also an option to set the Centerline to a Railroad format.

**Current Centerline**

Centerline: C:\Carlson Projects\Data\DEMO.cl

Centerline: 0+00.000 to 3+08.327

RR

- Remove: This button deletes the current line.
- High-Low: This button can be used to calculate high and low points.

**High-Low points**

PROFILE: C:\Carlson Projects\Data\DEMO.pro  
High Point STATION 105+00.176 EL:528.0991  
Low Point STATION 113+00.679 EL:522.9504

- Save As: This command will save your profile to a specified file name. There is no need to enter a file extension. If you want to save the file as Baker.pro, just enter "Baker". The Save As command will default to the current profile name. If you are entering a new profile, it will default to the current coordinate file name.



## 8.4 Draw Profile



The **Draw Profile** command will draw the selected profile on the screen. The profile will be exaggerated (typically 10:1 or 20:1) in order to maximize detail. You can control the vertical exaggeration by selecting the vertical scale icon, located at the lower left of the Draw Profile screen. All the zooming commands [Zoom In, Zoom Out, Zoom Window, Zoom Previous and Pan] are available to you in the Draw Profile command.

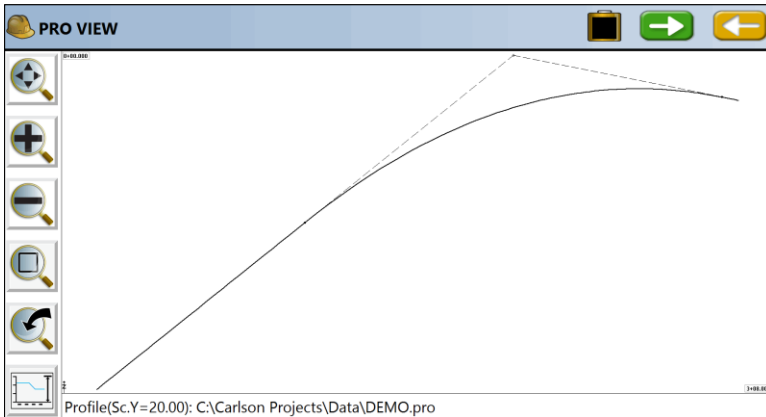

If you want to change the display scale, click the icon in the lower left corner. The dialog shown below will appear. Change the scale and tap **OK**.

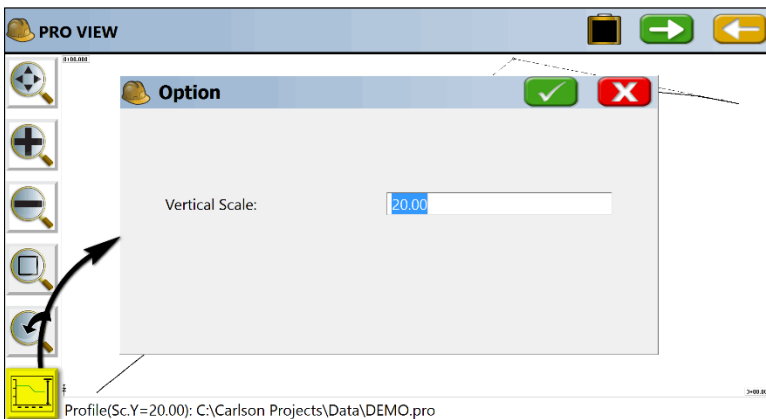



## 8.5 Template Editor



Templates for roads, levees, ditches and other earthwork can be created in Carlson Software products such as Carlson Civil or Carlson Roads, or alternately they can be entered in the field using **Input/Edit Template**. These templates can then be used in Carlson SurvPC in the **Stake Slope** command, where the template is one of the design files for slope staking, along with the centerline and the profile. Templates are also used in **Stake Road** (for staking those portions of the road from left shoulder to right shoulder) and for **Elevation Difference** by Road Design Files. Templates can be reviewed graphically using the command **Draw Template**. Templates are not necessary for the command **Stake Offset**, found on the SURVEY tab. In Offset Stakeout, road or other cross slopes from centerline are entered within the command itself.

Currently, SurvPC uses only templates created in Carlson Civil and Carlson Roads or entered directly within SurvPC using the command Template Editor. Every point on a template has an ID such as “EP” and “SH” or “CB1”. Templates in SurvPC have only one surface—the surface you are staking. To stake out a subgrade, you could enter the surface grade information, then use a vertical offset in **Stake Road** or enter the subgrade surface directly as a template.

After selecting **Template Editor**, you are presented immediately with the input dialog shown in the figure below. If an existing template is loaded (based on the last template used), you can clear the screen by clicking the clear icon (eraser) in the upper right.

Input-Edit \*.tpl File

C:\Carlson Projects\Data\DEMO.tpl

GRADES:  Right Side Same as Left

Left SURFACE			Right SURFACE		
Distance	Slope	ID	Distance	Slope	ID
10.000	-2.000%	EP	10.000	-2.000%	EP
CURB	CB		CURB	CB	
6.000	4.000%	SH	6.000	4.000%	SH

Add Edit Remove Up Down

Cut/Fill Super Load Save

Template grades are entered top to bottom and extend out from the middle position of the template. If you are dealing with a symmetrical template, keep the **Right Side Same as Left** option enabled. This will reduce entries by half. Otherwise, you must select the appropriate side and use **Add** to add entries or **Edit** to revise. One trick, if





you have non-symmetrical grades, is to keep **Right Side Same as Left** on and enter the symmetrical portion (perhaps the pavement lanes and first shoulder lane), then when you get to the outside shoulder or other lane where one side is different than the other, disable **Right Side Same as Left** and complete the non-symmetrical portion of the template. With the **Right Side Same as Left** turned off, you can click the words **Left SURFACE** or **Right SURFACE** and the left or right columns become active for editing. Alternatively, you may simply click into the items in the columns and edit or add.

In the curb-and-gutter template shown below, the **Add** option is used to enter the grade breaks from centerline out to the back of shoulder.

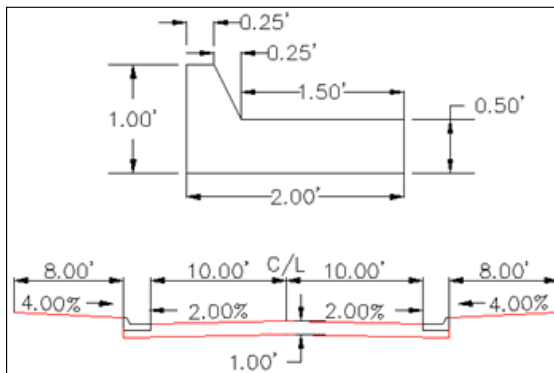

Since templates used in Slope Staking help define all grades into the centerline from the slope stake, it makes sense to focus on the subgrades that are built by the dozer, motor grader or trimmer. Thus, despite all the surface grades involved, there are only three distinct grades in this example curb and gutter template between centerline and the pivot point of the cut and fill slopes: 12.00 at -2% (subgrade at back of curb), 0.01 horizontal and 1 vertical, and 8.00 at 4%. For the **Vertical** method, some positive horizontal distances must be entered, such as 0.01 or 0.001.



By pressing **Add** in the dialog, we can enter the first two grades.

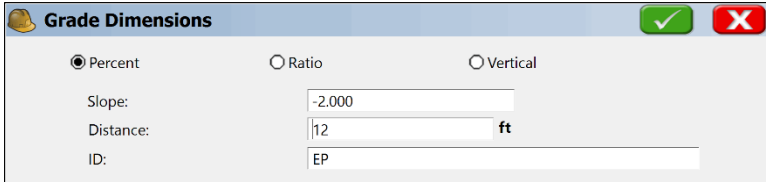

**Grade Dimensions** [✓] [✗]

Percent     Ratio     Vertical

Slope:

Distance:  **ft**

ID:

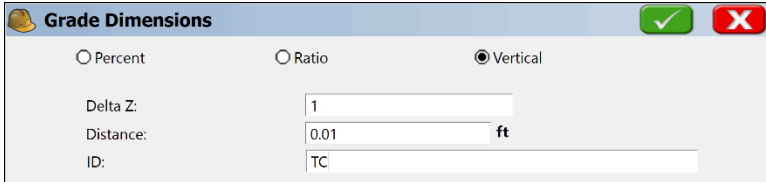

**Grade Dimensions** [✓] [✗]

Percent     Ratio     Vertical

Delta Z:

Distance:  **ft**

ID:

Downhill slopes, going out from the middle of the template, are entered as negatives. Note that it is necessary to enter an ID for each break point in the template. This helps identify the description of the grade on the progressive slope stake report (e.g. from the outside going in, 8' at -4% to TC, 0.01' at -1 vertical to EP, 12' at 2% to CL). The shoulder slope going out (8' at 4%) is entered similarly, as above. The Input-Edit Template dialog now appears.



**Grade Dimensions** ✓ ✗

Percent       Ratio       Vertical

Slope:

Distance:  **ft**

ID:

**Input-Edit \*.tpl File** ↶ ↷

C:\Carlson Projects\Data\DEMO.tpl

GRADES:  Right Side Same as Left

Left SURFACE			Right SURFACE		
Distance	Slope	ID	Distance	Slope	ID
12.000	-2.000%	EP	12.000	-2.000%	EP
0.010	1.000	TC	0.010	1.000	TC
8.000	4.000%	SH	8.000	4.000%	SH

You can press **Save** any time to save your work. Here the template has been saved and named “curb.” Now it is time to enter the Cut and Fill slopes, which are used in slope staking. If the cut slope is 3:1, but the fill slope is 4:1, you would select Cut/Fill above and enter as shown. Distinct left side and right side cut and fill slopes can be defined. After entry of the cut and fill slopes, press **OK** or **Enter** to return to the main **Template Editor** dialog, and press **Save**. Templates can be drawn using the command **Draw Template**.



**Cut/Fill Grades** ✓ ✕

Right Side Same as Left

Percent  Ratio

Left Side

CUT - Slope:	<input type="text" value="3:1"/>
FILL - Slope:	<input type="text" value="3:1"/>

Right Side

CUT - Slope:	<input type="text" value="3:1"/>
FILL - Slope:	<input type="text" value="3:1"/>

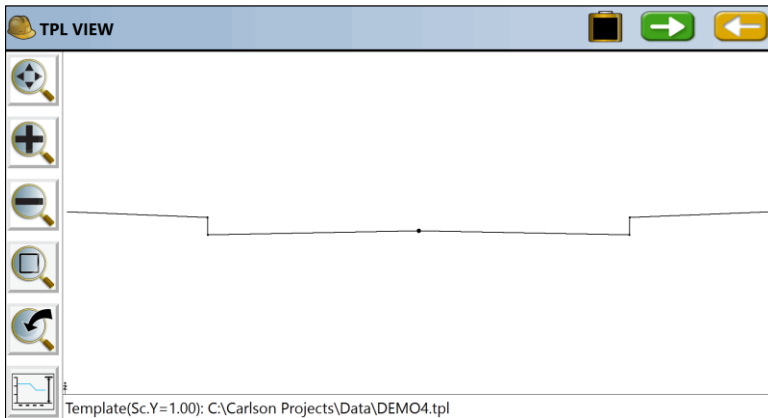

For highway projects or subdivision roads with cut slopes down to a ditch line, four template definitions may be necessary for slope staking: (1) Cut Left, Fill Right, (2) Cut Left, Cut Right, (3) Fill Left, Cut Right, (4) Fill Left, Fill Right. The appropriate template can then be used for any condition. Shown below is the Cut Left, Fill Right for a 2-slope (pavement and shoulder) road. The last slope in each column acts as the "pivot point" for the slope stake calculation. The fill slope is set at 4:1 and the cut slope at 3:1.



**Input-Edit \*.tpl File**

C:\Carlson Projects\Data\DEMO4.tpl  
GRADES:  Right Side Same as Left

Left SURFACE			Right SURFACE		
Distance	Slope	ID	Distance	Slope	ID
0.010	1.000	TC	12.000	-2.000%	EP
8.000	4.000%	SH	8.000	-4.000%	GB
12.000	-3.000:1	BD			

Add Edit Remove Up Down  
Cut/Fill Super Load Save

**Cut/Fill Grades**

Right Side Same as Left

Percent  Ratio

Left Side

CUT - Slope:	<input type="text" value="3:1"/>
FILL - Slope:	<input type="text" value="4:1"/>

Right Side

CUT - Slope:	<input type="text" value="3:1"/>
FILL - Slope:	<input type="text" value="4:1"/>

Using this template, cut slopes on the left side of the road will find the pivot at the base of ditch, while fill slopes on the right side of the road will pivot from the edge of shoulder.



## 8.6 Draw Template



The **Draw Template** command will draw the selected template on the screen. All the zooming commands [Zoom In, Zoom Out, Zoom Window, Zoom Previous and Pan] are available to you in the Draw Template command. Tap the **Menu** button to exit this command. The figure below illustrates this command using the “Highway Road.tpl” template.

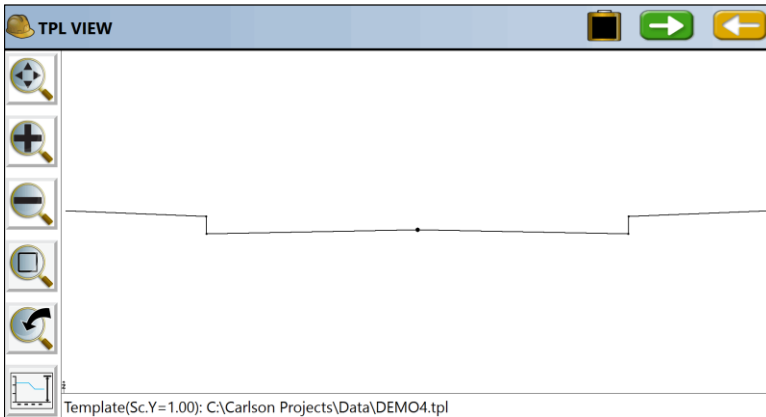



## 8.7 Utilities



**Road Utilities** includes necessary routines to convert centerlines, profiles and cross - sections from other formats to the formats used by SurvPC. SurvPC uses ASCII file formats for centerlines (“.cl” files), profiles (“.pro” files) and cross - sections (“.sct” files). These same formats are used by other Carlson products such as Carlson Civil (formerly SurvCADD), Carlson Survey, Takeoff and Construction.

Road Utilities will also scale up or down centerlines and profiles, usually to convert between metric and English units. In addition, Road Utilities includes a command for entering a superelevation file (“.sup”). This file can serve as an optional input file and react with templates in commands such as **Stake Road**, **Slope Staking** and **Elevation Difference**. Road Utilities has an option for a Template Series file (“.tsf” file). This file will transition from one template to another automatically between designated stations, as long as the templates share identical IDs. The Template Series file can be substituted for a standard template file in **Slope Staking** and **Stake Road**, wherever design files are applied. Finally, a "Template Grade Table" can be entered in Road Utilities, which designates slopes and offsets that apply left and right of centerline for any road segment, between which a proportional grade and lane width transition is calculated. Template Series files and Template Grade Tables are alternate methods of transitioning roads of variable width or slope and should not be used in combination in the same station range.

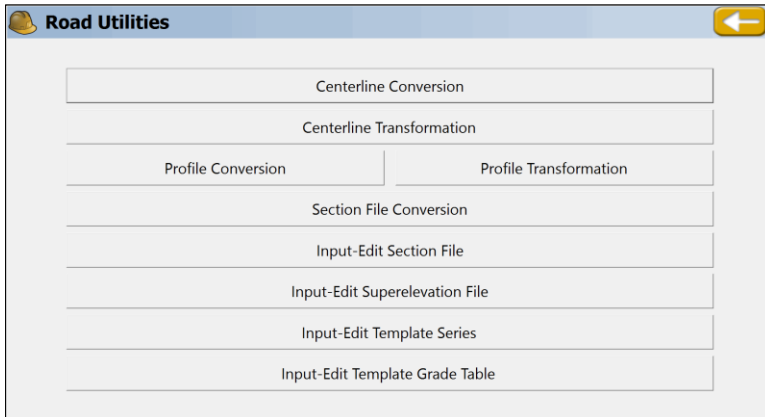



**File Conversion and LandXML:** The LandXML file format is becoming an encouraged standard of many departments of transportation (DOTs). This standard is also recommended by Autodesk, Bentley and Carlson. LandXML files have an “.xml” extension and may contain multiple road design files including centerlines, profiles, and cross - sections. The “header” lines within the “.xml” file will indicate what design files are included. In some cases, several files of the same type, such as three or four centerlines or profiles, may appear in the same LandXML file. As more and more software companies offer LandXML file output, this file type may become the preferred form of data exchange. Be aware that each company tends to implement the LandXML format in slightly different ways, much like DXF files for drawing data exchange were sometimes slightly different in format between Autodesk and Microstation, or from release to release. Therefore, if a LandXML file containing centerlines, profiles or cross - section files fails to convert, it is recommended that the file be emailed to Carlson Software so changes can be made in SurvPC to enable conversion. LandXML is an evolving format that is likely to solidify in the near future.

### **Centerline Conversion**

This command converts horizontal alignment files to and from the Carlson centerline format (\*.CL). Supported file types include:

- ASCII Inroads (.ASC)
- ASCII LDD (.TXT)
- Caice (.KCP)
- CLIP (.PLA)
- Geopak (.OSD)
- cutsheetc)
- LandXML (.XML)
- Leica (.GSI)
- MOSS (.INP)
- SDMS (.ALI)
- SDR (.SDR)
- SMI Chain (.CH)
- TDS (.RD5)
- Terramodel/Geodimeter (.RLN, .ALN and .ARE formats)

The SurvPC format has a “.CL” extension. These source files can be loaded into SurvPC using **Data Transfer**, located in the File menu options. When performing the conversion, and selecting a particular format, SurvPC automatically looks for the corresponding file extension.



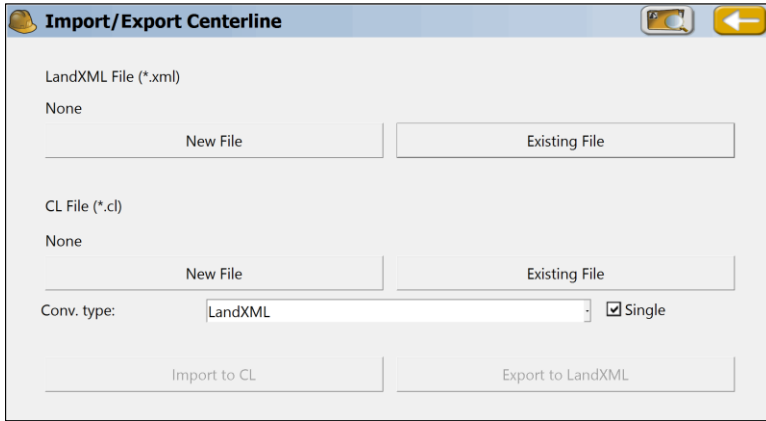

**Report Icon for LandXML Files:** If you are importing a LandXML file specifically, you can click the Report icon left of the "Return" icon in the upper right of the dialog, and review the source of the data.

**Conversion:** Clicking **Existing File** in the upper right (in the Land XML section) will load the file, and clicking **New File** under the CL File section will save the centerline file in the correct format for use in SurvPC. To convert in the opposite direction, select **Existing File** under the CL section to recall a SurvPC centerline file, and then click **New File** in the upper left (under LandXML file) to save it back to a LandXML file, for use in other software.

For file types in which both Import and Export options are available, the conversion procedure forms a "criss-cross": You bring the files into SurvPC by going upper right ("Existing") to lower left ("Select New"). You send the files back to the "non-SurvPC" format by going lower right ("Select Existing") to upper left "New".

When the files have been selected, the appropriate action is highlighted below, "Import to CL" or "Export to <type>". When the process is completed, the program announces "Process Done," and you are free to move on to the next command. Most formats only convert to SurvPC and not back again, and therefore only have "one-way" dialogs. These include ASCII-Inroads, ASCII-LDD, Geopak, Moss, TDS and Terramodel/Geodimeter.

### Importing TDS RD5 Files

**Importing TDS RD5 Files:** If TDS is selected, centerlines can be converted one-way to SurvPC centerlines (centerline files CANNOT be converted back to TDS files). It is important to note that the TDS RD5 file is a dual centerline and profile file. Because the TDS RD5 file does not display the starting station, an extra dialog will appear requesting starting coordinates (which can be recalled from a point) and a starting station.



Starting Station:	<input type="text" value="0+00.000"/>
Point From File:	<input type="text"/>
	<input type="checkbox"/> <input type="checkbox"/>
Starting Northing:	<input type="text" value="0.0000"/>
Starting Easting:	<input type="text" value="0.0000"/>

### Verify the Conversion

It is recommended that after converting centerlines, profiles or cross - section files to SurvPC format, you go to the Editor and Draw options for these file types and review the data to verify that the correct file was converted and that the conversion was successful. So, for example, after converting a centerline from Inroads format to SurvPC “.cl” format, go directly to **Centerline Editor** in the Roads menu and verify the data.

### Recognizing File Formats

For reference, portions of four of the file types are shown below, as they might display in a Text Editor. The LandXML, SurvPC and SDR examples all reference the file DOT1.CL. These displays may help you recognize these file types in the future. The new LandXML format, endorsed by many Departments of Transportation in the United States, may soon become the standard in the future for internet transfer of roading and other types of design files.

LandXML	<pre>&lt;CoordGeom&gt; &lt;Line length="848.64000000" dir="2.38921515" &gt; &lt;Start&gt;10000.00000000 10000.00000000&lt;/Start&gt; &lt;End&gt;10579.94056914 9380.43661675&lt;/End&gt; &lt;/Line&gt; &lt;Curve rot="ccw" chord="1914.99460706" crvType= &lt;Start&gt;10579.94056914 9380.43661675&lt;/Start&gt; &lt;Center&gt;2213.99512832 1549.51682467&lt;/Center&gt; &lt;End&gt;11767.20701020 7877.90450628&lt;/End&gt; &lt;/Curve&gt; &lt;Line length="1947.71000000" dir="2.55652497" &gt;</pre>	SDR	<pre>00NMSDR33 V04-04.24 Jul-29-99 14:49 122211 28KIDOT1 1 06NM1.00000000 29NM10078.6900 313.108056 10000.0000 30NM10579.9406 9380.4366 32NM1917.2300 -11459.1600 30NM11767.2070 7877.9045 30NM12842.8412 6254.1479 32NM1443.1116 -11459.1600 30NM13562.0477 5004.1230 30NM17287.5650 -2531.7846</pre>
SurvCE	<pre>0,10078.69000,L,10000.00000000,10000.00000000 0,10927.33000,L,10579.94056914,9380.43661675 0,10927.33000,PC,10579.94056914,9380.43661675 0,9,351012766,R,2213.99512832,1549.51682467 0,12844.56000,PT,11767.20701020,7877.90450628 0,14792.27000,L,12842.84117284,6254.14793824 0,14792.27000,PC,12842.84117284,6254.14793824 0,7,125600000,R,3289.62929108,-74.23974329 0,16235.38163,PT,13562.04766716,5004.12304528 0,24641.89003,L,17287.56502100,-2531.78459252 0,24641.89003,TS,17287.56502100,-2531.78459252</pre>	TDS	<pre>HR+++++ HL,77.0204,151.834 HC,-1.0,300.0,114.436,L HL,-1.0,128.892 HC,-1.0,800.0,846.144,R VR+++++ VG,47.02,0.000000 VG,215.48,5.000000 VC,75.0,5.000000,8.000000 VG,25.0,8.000000 VC,75.0,8.000000,9.430000</pre>



## Centerline Transformation

This routine is designed primarily to convert centerline data from Metric to Survey Feet or from Survey Feet to Metric. The image below shows the dialog and scale factor when converting from Metric to Survey Feet.

**CL Transformation**

Current CL File:  
None

Select File

Scale Factor: 3.280833333

Metric to Survey Feet  
 Survey Feet to Metric  
 Custom Scale Factor

Apply scale factor for start station

Apply Scale Factor

**Apply scale factor for start station:** If this option is enabled, then the starting station will be converted using the scale factor. For example, a start station of 1000 would become 3280.833. If disabled, the start station would remain at 1000. If the goal is to change the starting station by a certain amount unrelated to the scale factor, then you must use **Input-Edit Centerline** and enter a new start station in the initial dialog. This will automatically translate all stations in the centerline by the appropriate amount.

When **Apply Scale Factor for start station** is enabled, the centerline is adjusted by the scale factor, after a confirming warning screen.

## Profile Conversion

This command converts vertical alignments to and from the Carlson profile format (\*.PRO). Supported file types include: ASCII-LDD (.TXT)

- Caice (.KCP)
- CLIP (.ALZ)
- ISPOL (.RAS)
- LandXML (.XML)
- Leica (.GSI)
- MOSS (.INP)
- SDMS (.PRO)
- SDR (.SDR)
- SMI (.CH)
- TDS (.RD5)
- Terramodel/Geodimeter (.RLN, .ALN and .ARE)



The SurvPC format has a .PRO extension. These source files can be loaded into SurvPC using the **Data Transfer** feature in the FILE tab. The conversion screen is similar to Centerline Conversion, with the characteristic “criss-cross” logic for 2-way conversion (LandXML and Leica) and one-way import only conversion for the other options.

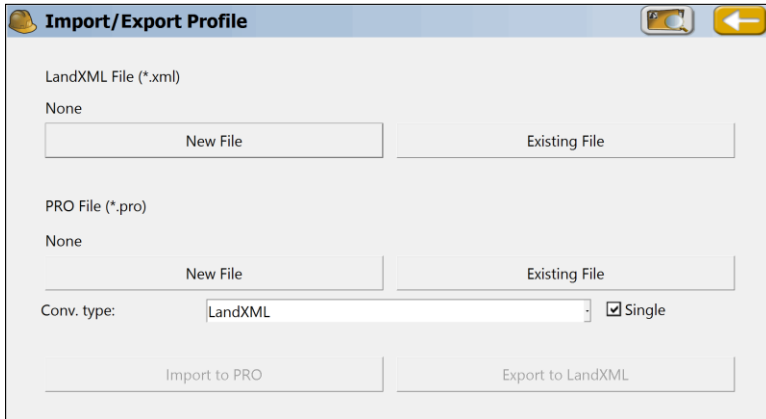

**The SurvPC Profile File Format:** It should be noted that of all the SurvPC file types that are ASCII and therefore viewable in standard text editors, the profile (.pro) file has the simplest format. The format is station, elevation, length of vertical curve, and description for road profiles. For example, the Demo.pro file that is typically provided with the software has the following four lines (which can be viewed in Notepad):

```
0.0000, 997.0000 , 0.0000,  
200.0000, 1005.0000 , 200.0000, (200 foot vertical curve length)  
308.0000, 1003.9200 , 0.0000,  
0.0, 0.0, 0.0 (this is an “end-profile” line)
```

Profile files can be created from within SurvPC, but are simple enough to be hand-entered using a text editor as well. Unequal vertical curve lengths can be entered in the form 150-50, indicating 150 units to the point of vertical intersection and 50 units to the point of vertical tangency. Other ASCII file types, such as centerlines, can be deciphered, but are generally of a more complicated design and are best created using the editors provided within SurvPC.

### Profile Transformation

Like Centerline Transformation, this routine is primarily used to scale a profile up or down to go from Survey Feet to Metric or from Metric to Survey Feet.



Unlike **Centerline Transformation**, **Profile Transformation** can directly translate the profile up or down. You can also scale the profile stationing and elevations. If you want to apply a translation to selected stations, tap the **Translate** button.

The Translate option leads to its own dialog of entries, which allows you to translate both the stationing and the elevations, as shown below. In this way, you can make the starting station 1000, or raise the entire profile 15 feet or meters.

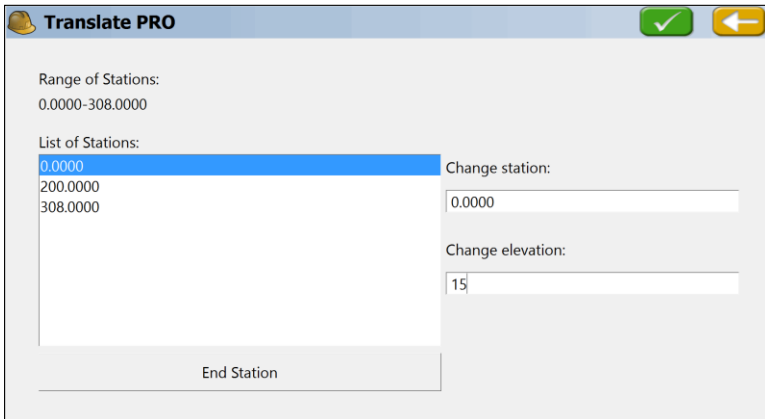

By default, the entire range of stations is selected. If you wish to only translate a range, highlight the beginning station, then click **End Station** and highlight the end station. Next, enter the amount to translate in the **Change Station** box. You may also translate the elevation using the **Change Elevation** box. **Tap OK when you are finished.**

### Section File Conversion

This command converts section files to and from the Carlson section file format (\*.SCT). Supported file types include:

- Caice (.FFF)
- CLIP (.TRV)
- Geopak (.XRS, .XSR, .SOE & .TXT)
- IGRDS (.LIS, .RDS & .TXT)
- Inroads (.TXT)
- ISPOL (.SC1 & .RAS)
- LandXML (.XML)
- Columnar Text (.TXT, CSV & .ASC)
- Terramodel/Geodimeter (.XSC)

The SurvPC format is “.SCT”. Section files are used for **Stake Slope**, **Stake Road** and **Elevation Difference**. **Cross - section Survey** also has the ability to output section files. TDS will store cross - sections in an RD5 format that behave as a series of templates, following "rules" for slopes coming from the design profile grade. You can



import TDS-style cross - sections using **Input-Edit Template Series** within Road Utilities, and for "Files of Type", select TDS.

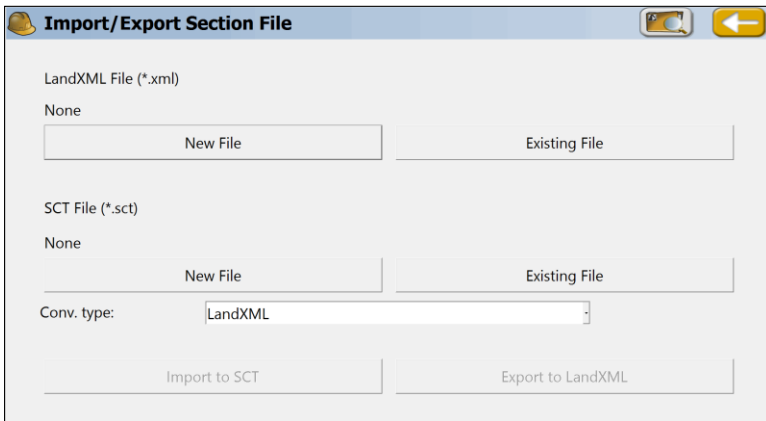

Note that if you select XML Info at the top of the screen, you'll see some of the "header" information associated with the XML file to be exported or imported.

To export to LandXML, you need to load a LandXML file that already contains a centerline covering all or part of the station range in the SCT cross - section file. Otherwise, you will see an error message.

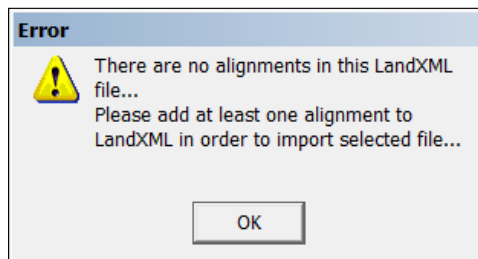

Despite the message, you can add the horizontal alignment portion to the LandXML file after creating the file with sections only. However, if you first create a LandXML file containing one or more alignments, then choose that existing LandXML file to export to, you can select among those centerline alignments when making the cross-section file.

Section files in SurvPC can contain descriptions useful for reference in other routines such as **Stake Road**. If descriptions are found in the source section file, they will be captured by the import process into the ".sct" file for use in SurvPC.



Pipes running longitudinally along horizontal alignments can be imported in the form of cross - sections using the Columnar Text form. The example below shows the layout of the pipe format that is recognized by SurvPC.

```
STA,Offset,FL elev.,Link - ID,Link - Library Item,Type
13+00.00,52.13,22.32,NP-26,18" RCP,T
14+00.00,-47.61,22.08,NP-1,18" CMP,T
14+00.00,49.63,22.02,NP-26,18" RCP,T
15+00.00,-39.58,21.78,NP-1,18" CMP,T
15+00.00,49.15,21.73,NP-27,18" RCP,T
16+00.00,-38.00,20.22,NP-3,24" RCP,T
16+00.00,48.92,21.45,NP-28,18" RCP,T
```

Within Stake Road, Section Method, the pipes can then be loaded as a cross - section file and the pipe inverts can be staked in the same way that road cross - section points can be staked. The pipe format is recognized and the pipes display with their correct diameter shown. Note the ability of the program to display the pipe size, captured as the 5th field in the ASCII file (above):

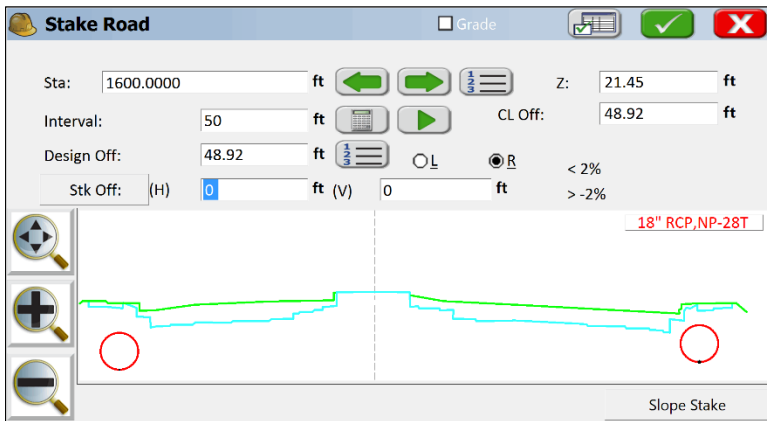

### Input-Edit Section File

This routine is a convenient cross - section editor. It can be used for entering new sets of cross - sections or for editing and reviewing an existing set of cross - sections. One nice application is **Slope Staking**. If you know the left and right “pivot points” on stations to be slope staked, you can enter very simple, two-point cross - sections consisting of the left pivot offset and elevation, and the right pivot offset and elevation. Then, without taking a cheat sheet into the field, you can slope stake by cross - section method, and the program will seek these pivot points, and even interpolate the correct pivot points between entered cross - sections.

A better approach would be to include all break points in the sections from pivot left to pivot right, along with descriptions. Then Slope Staking will report the progressive



information to grade each point from the catch all the way into centerline. This “section-based slope staking” is a cross between user-defined (where you need the cheat-sheet!) and design files, where the pivot offsets and elevations are taken from the pivot points in the template as they react with the profile and superelevation files. Sections used in **Stake Road** should be complete cross - section files, with all offsets, to enable precise, interpolated stakeout within the left-to-right range of the sections, on station, or at interpolated stations.

The Input-Edit Section File routine begins by prompting for a cross - section file name. If you wish to start a new cross - section file, just enter a new name.

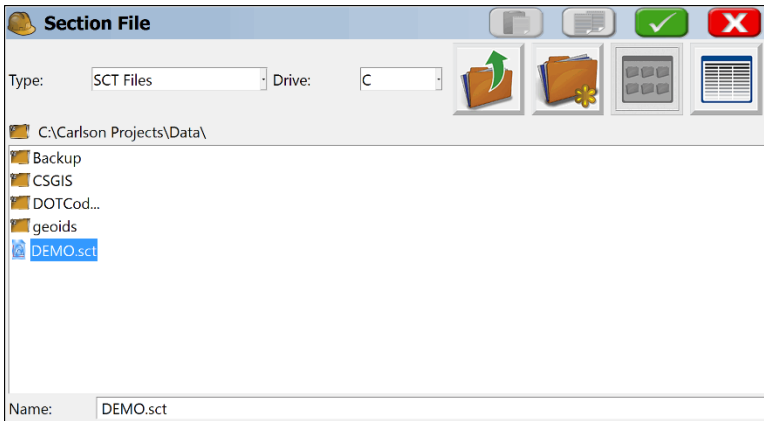

If you choose to select an existing cross - section file, such as DEMO.sct, after selecting the file, you will see the “Section List” dialog.

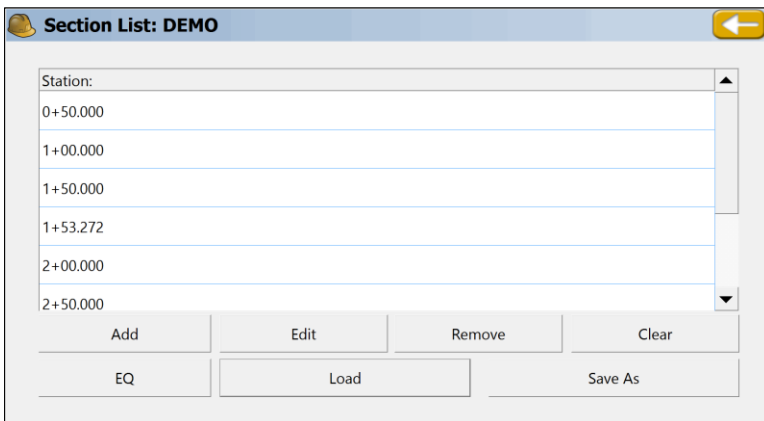

From this dialog, you can **Add** stations, **Edit** existing stations, **Remove** stations, **Load** entire new cross - section files, **Save As** (to save your changes to the current loaded file





or to a new cross - section file), and **Clear** the list of stations (not recommended unless you want to start from scratch). Select **Edit** to review a station.

Offset	Elevation	Description
-100.000	1004.253	INTERPOLATED
-63.461	1003.229	
-54.358	1002.973	
-21.891	1001.976	
-6.779	1001.562	

Edit Station:  ft

Add Edit Remove

Up Down Clear

In this dialog, you can **Add**, **Edit**, **Remove**, **Rearrange**, or **Clear** existing offsets and elevations. Note that cross - section offsets are negative for left of centerline and positive for right of centerline, and can have descriptions such as SH, EOP, CL, Ditch, 21, 22, 23, etc. These descriptions, where they exist, are potentially useful for description-based interpolation between stations, as applied in **Stake Road**. If you want to add an offset at -42.867 called RP, click **Add**. You don't have to highlight the correct offset to add above — the software will sort and place the new entry appropriately.

Offset:

Elevation:

Description:

When you click **OK**, your new entry will be in the list.

The **Edit** box leads to the same entry dialog as **Add**. **Remove** will provide a warning and then delete the highlighted offset and elevation. **Up** and **Down** should not be used unless a file conversion led to out-of-order listing of offsets and elevations. When you



click **OK** from the station edit dialog, you can save the revised cross - section file back in the section list dialog.

### Input-Edit Superelevation

Roads can contain one or more curves, and each curve can have its own superelevation data. This data includes start station for super transition, station for full super, percent of full super, station for end full super, and station for ending the super transition back to normal crown. In SurvPC, each superelevation data set for each curve would be entered as a “line” of superelevation data in the “.sup” file.

If we had two curves, both with superelevation, then we would do two Adds using this dialog. Let’s say, for simplicity, that we have a road with a 2% “normal crown” which has one curve to the left followed by one curve to the right, with the following information:

	Curve 1	Curve 2
Start Super Pivot	Sta: 100	Sta: 2200
Full Super	Sta: 600	Sta: 2500
Full Super %	3% Left	4% Right
End Super	Sta: 1400	Sta: 3500
End Super Pivot	Sta: 1900	Sta: 3800

The first curve to the left goes through three stages as it pivots into full super: (1) the right side pivots to “flat”, (2) the right side pivots to “reverse crown”, where the slope is the same across the template and (3) both the right and left sides pivot from the hinge point (centerline) into full super. All of these key pivot points are entered in the superelevation dialog.

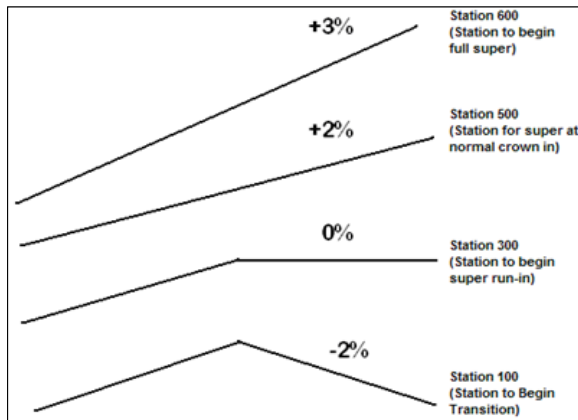

You enter all these key stations (begin, flat outside lane, reverse crown, full super) both going up to full super and transitioning back down to normal crown. Recognizing that the normal crown of -2% transitions from station 100 through a slope of 5%, the transition is 1% per 100 feet, assuming an even rate of transition. Therefore, a “flat”



outside slope occurs at station 300, reverse crown at station 500 and full super at station 600, as shown. You will need to compute these stations in advance. These intermediate stations are entered in the superelevation dialog to allow for different rates of transition from normal crown to flat to reverse crown to full super. Normally, the rates of transition are consistent. Note that super left or right is always entered as a positive percent slope — the road centerline curve direction will control the direction of pivot. You are now ready to click **Add** and enter in Curve 1.

Begin Transition:	1+00.000	ft	Begin Run-In:	3+00.000	ft
Reverse Crown rate in:	5+00.000	ft	Grade Slope(%):	3.00	
Design Speed:	35.00		Curve Type:	<input checked="" type="radio"/> Spiral	<input type="radio"/> Circular
Max slope of Full Super(%):	3		Begin Full Super:	6+00.000	ft
End Full Super:	14+00.000	ft	Reverse Crown rate out:	15+00.000	ft
Reverse Curve:	<input type="checkbox"/>		End Run-Off:	17+00.000	ft
End Transition:	19+00.000	ft			

When you click **OK**, the first line of the superelevation dialog is filled in. Curve 1 is complete.

Next, we enter Curve 2 as follows, using similar logic.

Begin Transition:	22+00.000	ft	Begin Run-In:	23+00.000	ft
Reverse Crown rate in:	24+00.000	ft	Grade Slope(%):	4.00	
Design Speed:	35.00		Curve Type:	<input checked="" type="radio"/> Spiral	<input type="radio"/> Circular
Max slope of Full Super(%):			Begin Full Super:	25+00.000	ft
End Full Super:	35+00.000	ft	Reverse Crown rate out:	36+00.000	ft
Reverse Curve:	<input type="checkbox"/>		End Run-Off:	37+00.000	ft
End Transition:	38+00.000	ft			

When **OK** is clicked, the two curves are complete and the summary dialog appears. There is one line (or row) for each curve.

*Note: If any of the columns are too narrow to display all the text, you can “grip” the vertical line separating columns, much like in programs such as Excel, and make the column wider.*



Superelevation List: 20170213				
Beg Trans	Run-In	Norm Out	Run-Off	End Trans
1+00.000	3+00.000	15+00.000	17+00.000	19+00.000
22+00.000	23+00.000	36+00.000	37+00.000	38+00.000

Add	Edit	Remove	Clear
EQ	Load	Save As	

The superelevation file is one of the optional “roading” or “design” files in **Stake Slope**, **Stake Road** and **Elevation Difference**. After a superelevation file has been entered and saved, it will appear as the default superelevation file in all of these commands, unless removed from the design file list by the user.

### Input-Edit Template Series

SurvPC allows for two types of transitioning: (1) a single template can transition by being “acted upon” by template transition files (made in Carlson Roads, Topsite, Leica Site Manager or Carlson Civil) and superelevation files, or (2) a template series file can transition between several templates sharing identical IDs, but having different slopes and widths between ID points within the templates.

You can load an existing TDS template series file, in the RD5 format, by clicking Load, then clicking the down - arrow for Type of File, and selecting TDS format. TDS templates always have IDs and the same number of template points per cross - section, so once imported, they behave exactly like SurvPC-defined templates. Using the Draw Template option, any particular template in a template series file can be selected and displayed as shown:

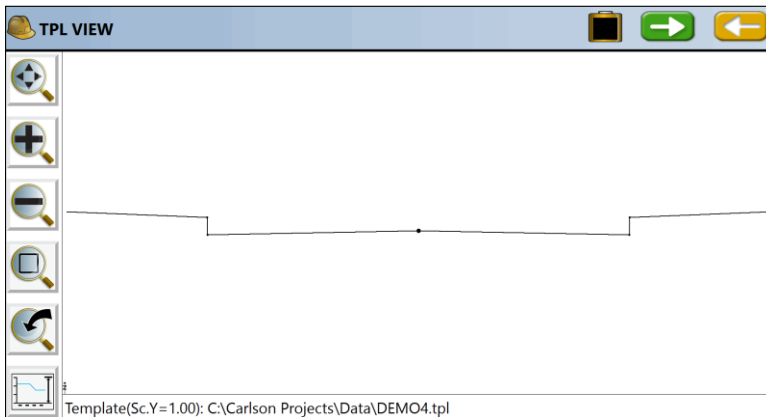

The Template Series approach can even be used to transition from normal crown to superelevation, avoiding the need to use superelevation files. The Template Series approach is commonly used to expand the width of a lane to accommodate, for example, a passing lane. Since template IDs must match, if a “special slope” lane



“appears” for a certain station range, then the Template Series approach can still be used as long as you add the extra ID point (e.g. EP2) to the normal template, perhaps making that point 0.001 units in dimension initially. In the second, transitional template, the EP2 lane can have the full width of 3.5 meters or 12 feet or whatever applies. If the transition starts at station 500 and ends at station 600, EP2, will be 1.75 meters or 6 feet or exactly half the full dimension at station 550.

Starting with the demo.tpl file, with a 10’ lane to ID “EP” followed by a 6’ shoulder lane to ID “SH”, you can make another template called Road.tpl, with a 12’ lane to “EP” and an 8’ shoulder to “SH”. Note how we have made sure to use the same ID for the road lane (“EP”) and the shoulder lane (“SH”).

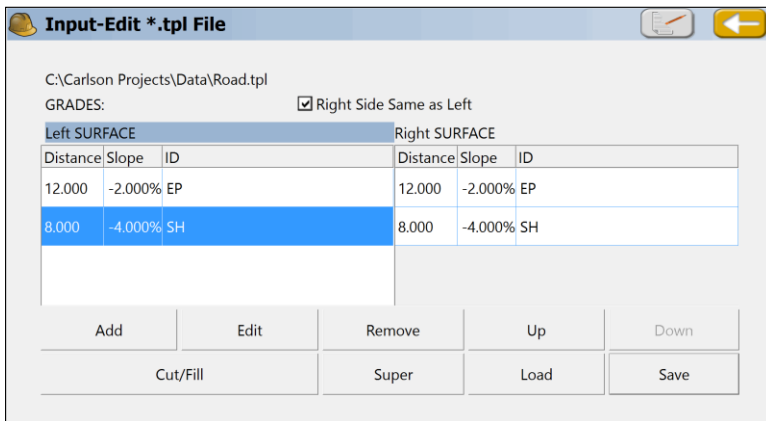

If the demo.tpl is used from station 0 to 500, and the Road.tpl is used from 600 to the end of the project at station 1000, then the entry process for a Template Series is as follows:

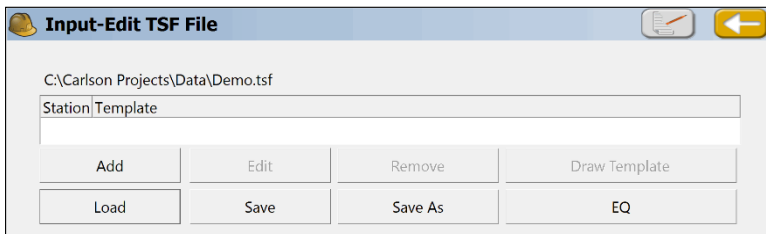



Click Add and you will obtain the next dialog.

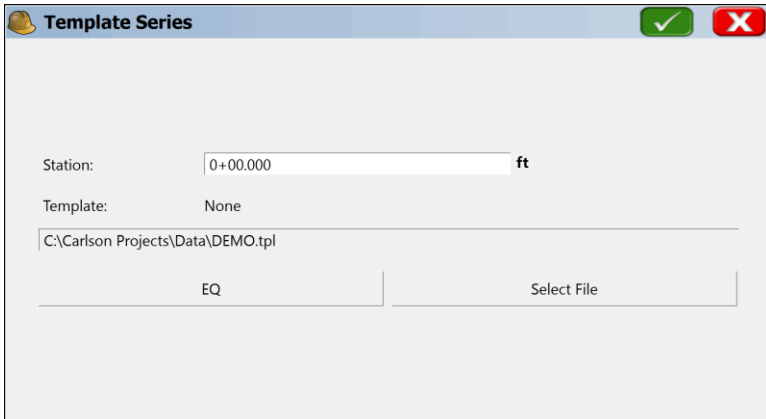

Choose Select File and pick the first template (demo.tpl). Click OK. Back in the main dialog, click Add again and specify the ending station for demo.tpl as station 500. Then click Add again and specify the first station for Road.tpl as station 600. You do not need to specify an end station, as Road.tpl will be used for the remainder of the project.

You then Save the Template Series File. When running **Stake Road, Stake Slope** or **Elevation Difference** by **Roading Design Files** and recalling a template file, you have the option to recall a Template Series File and process a set of transitioning templates.

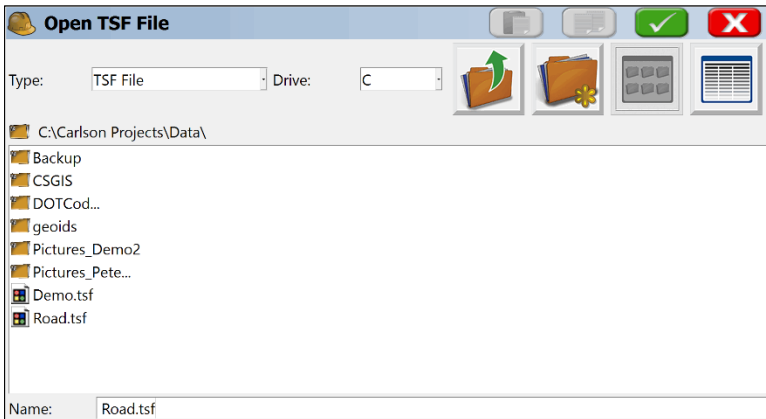



## Input-Edit Template Grade Table

Very complex roads such as exit ramps, with widening and shrinking lane widths and slopes that do not follow a simple superelevation pattern but instead adapt to meet grades of intersecting roads, can be defined using the Template Grade Table feature. Although template series files can be used to model any road, the creation of multiple templates, including all lanes, can be a labor-intensive process compared to entering the precise slope and width for particular template ID points. These slopes and widths are often provided in tabular form in the design documents, so direct entry of the slope/width data, applied to the appropriate template ID or several IDs, is often the most efficient way to handle complex road conditions.

Consider a template that goes from the center of the road to SH and then to SH2. The second segment is always 8 feet dimension at a fixed slope. The first lane, from centerline, is paved and has variable width and slope. The template grade table is applied to the first lane, after which the normal template rules apply. After selecting the command, you name your new (or existing) template grade table, and then the template that it is associated with. This leads to the screen shown below:

Left SURFACE				Right SURFACE			
ID	Table	Distance	Slope	ID	Table	Distance	Slope
SHL	Yes	37.220	-2.000%	SHR	Yes	33.500	-2.000%
SH2L	No	8.000	-4.000%	SH2L	No	8.000	-4.000%

The normal slopes of -2% to the edge of pavement (inner edge of shoulder) and -4% to the outer edge of the shoulder would apply if the template behaved normally.

If you click Edit on the right shoulder, for example, you can enter station-based lane widths and slopes as shown below:



**Grade** 📄 ✓ ✗

ID: **SHR** Side: **Right**

Station	Slope %	Distance
10+85.450	1.610	32.5000
11+80.000	-3.900	32.5000
12+60.000	-3.900	32.5000
13+61.110		32.5000

Station:  ft Slope:

Dist:  ft  Show As Ratio

Show Zeroes

**Grade** 📄 ✓ ✗

ID: **SHR** Side: **Right**

Station	Slope %	Distance
16+08.080	4.700	16.0000
17+54.000	4.700	16.0000
18+14.000	2.000	16.0000
20+66.860	2.000	16.0000

Station:  ft Slope:

Dist:  ft  Show As Ratio

Show Zeroes

In this example, considering first slope, the road begins midway in transition, at slope 1.61% in a curve left, then transitions into a curve right with a slope of -3.9% at station 1180, greater than normal crown, holding this grade through station 1260. Then the road veers again to a curve left of 2% and holds that from station 1418 through 1480, after which it transitions to 4.7% at station 1540, holds that slope through 1754, and transitions back to a uniform cross slope of 2% at station 1814 where it remains through station 2066.86. Note that where no slope entry is entered (e.g. at station 1361.11 through 1381.25), the program transitions proportionally between the last actual entries provided (1260 and 1418).

While the slope is following the instructions of the slope column, the road lane width adheres to the distance column. So, if the right-side shoulder width is 32.5 feet through station 1361.1, you can enter that distance for all stations in that range, or you could simply bracket the distance by entering 32.50 for station 1085.45 and 1361.11 and leave 1180 and 1260 blank for distance. Either way, it will compute correctly. Then for each station where a distinct distance is given in the plans, a new station entry is made, such as at 1378.61 (30') and 1381.25 (28'). If the road transitions from 28' to 16' between





stations 1381.25 and 1608.08, then all stations used for slope in that range can be left blank for distance. For station 1608.08, the distance of 16' needs to be entered, to complete the distance transition, and the slope at 1608.08 can be entered (since it is known) or left blank. Either way, it will calculate correctly, since the 4.7% slope is governed by stations 1540 and 1754. Similarly, for the final stations 1754 through 2066.86, the known distance of 16' can be entered or left blank.

At station 1500, the right-side SHR lane is both in slope and in distance transition. The program will calculate this and you can review the slopes by using the Stake Road command, as shown below:

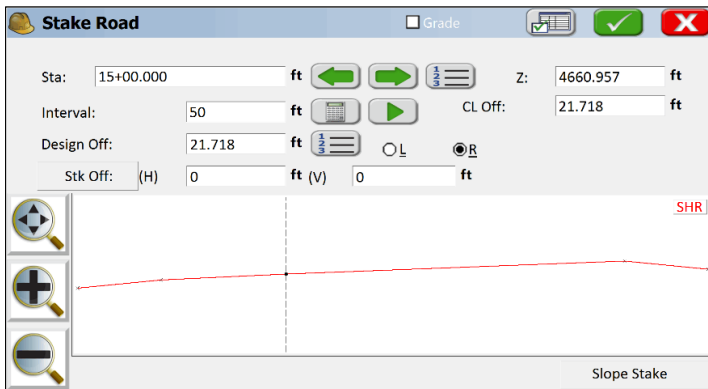
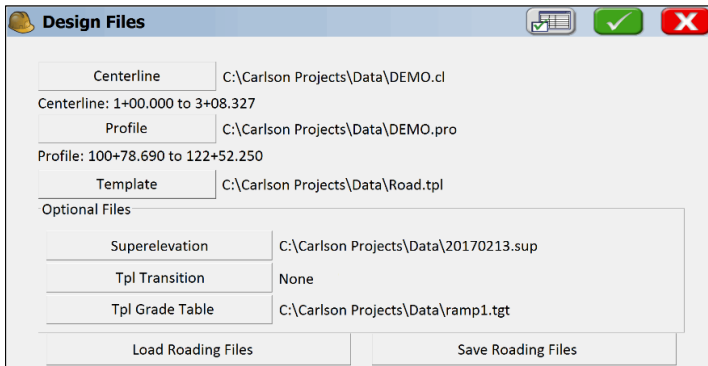

By clicking on the SHR ID point, the program displays the computed offset (21.718) and the computed slope in (2.901%) and slope out (-4%, per the standard template). A similar page of values was entered for the SHL ID point, leading to the uniform superelevated slope left to right. With the **Template Grade Table**, applied to as many template ID points as needed, any complex road can be defined. When running **Stake Road**, **Stake Slope** or **Elevation Difference** by **Roding Design Files** and recalling a template file, you have the option to use a **Template Grade Table** for precise modeling of complex roads.



## 8.8 Store Sections



This function collects as-built cross - sections of roads or other alignments and stores them optionally as points, as cross - sections or as an ASCII file, organized by station. The station and offset can be stored into the description field of the points. The station itself can be set to automatically round to the nearest 5, 10 or other station interval (e.g. a shot at 177+98.23 would round to 180+00 if a rounding of 5 or 10 is used). The information can be stored into a ".txt" ASCII file in addition to the points themselves, if "Store Comma Separated File" is turned on, and if point storage is turned on, you can save a ".not" file of the station and offset. You can save the cross - section data to a cross - section file in .SCT or RAW/Geodimeter format. Store Sections can also be used simply to verify your current station and offset as you move along a centerline using GPS or taking total station shots.

This routine is often combined with office software to check as-built road cross - sections against desired grade and to calculate quantities for payment. The field crew begins by taking shots along each desired cross - section, as shown in this figure.

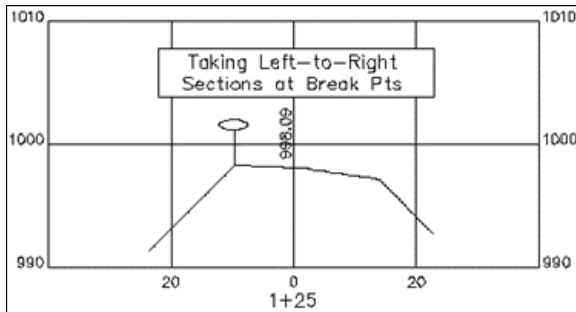

If four sets of cross - sections were taken from station 0+75 to 1+50, the points would appear as shown in the plan view below, and the 3D view shown below that. There is an option to turn off point number storing, in which case the shots can still be stored to a cross - section (.sct) file and report file (.txt).

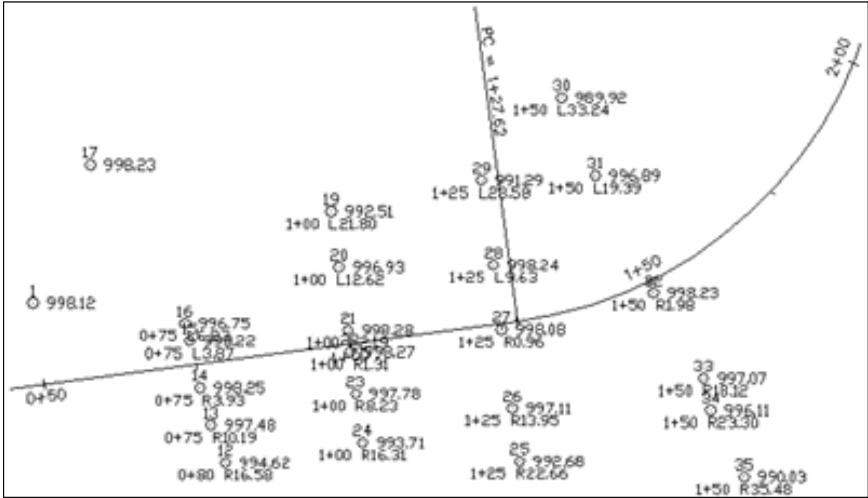

Here, below, we see the 3D view of this area.

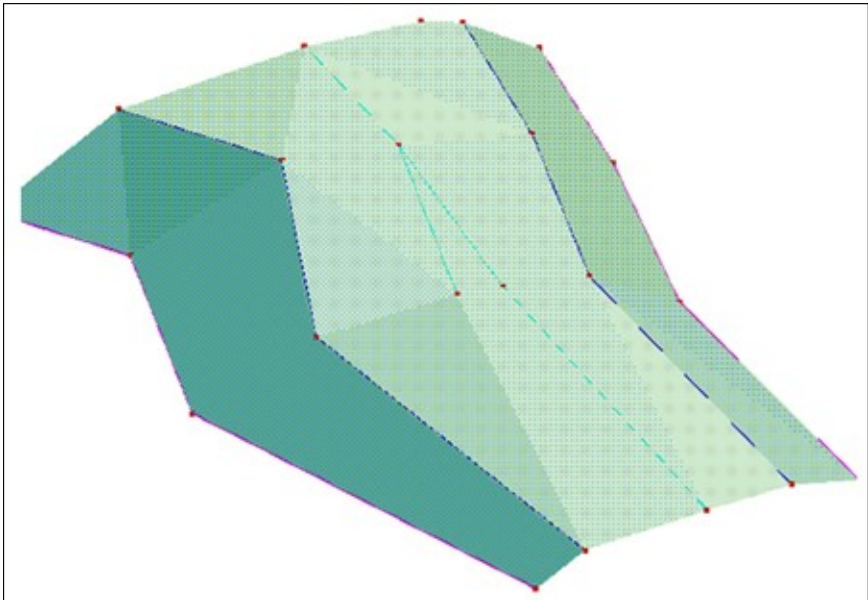



The command begins with a screen where you select the method for defining a centerline.

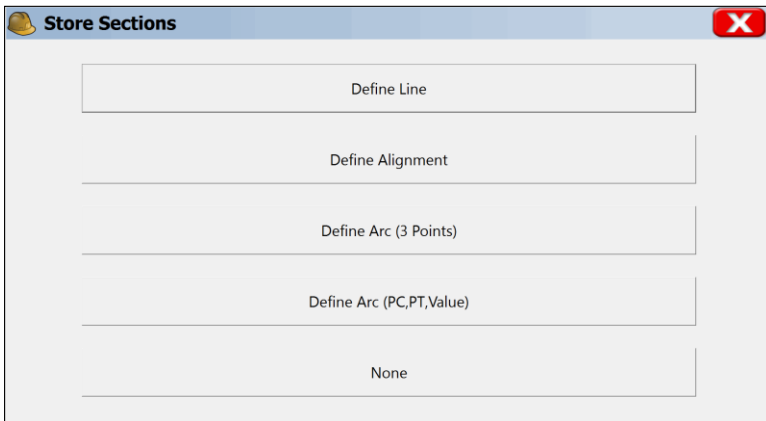

The next screen allows you to choose whether or not to store a file summarizing cross-section data. *This will be the fourth screen in the process of Define Line, Define Alignment, Define Arc (3 Point), Define Arc (PC, PT, Value).*

Because the SCT method requires that you choose an alignment, the option for no alignment (“None”) only applies to the Raw/Geodimeter method, in which case a named file is required. Except for this case of option “None”, the Section output file is optional because the information will be stored with the points. When you click Select File, you have two file type options when using a horizontal alignment.

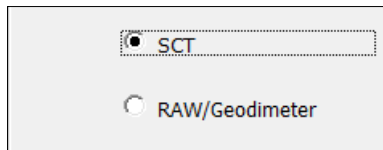

The Raw file format is a design that is compatible with the old Geodimeter section file format, and includes special prompting for job type. It is discussed in detail below (see the discussion of “None” as centerline option). It leads to a different set of screen options than the SCT format.



Unless you are looking for Geodimeter file format compatibility, you should consider storing a section output file in the “.SCT” format, since it can be converted, using Road Utilities, to LandXML form and then imported to several different roading software packages for plotting and computation of volumes. The “.SCT” section files can also be used directly for volume calculations with Carlson Roads, Leica Site Manager, Topcon Topsite and Carlson Civil. You can also set the rounding—here, a rounding of 10 units (feet or meters) has been selected. The station and offset can also be stored as the point description and as a note file, if the lower options are clicked on.

**Store Sections**

Store Data to Section File

Select File None

X-SCT Settings Station Tolerance: 2.000

Store Comma Separated File

Select File C:\Carlson Projects\Data\CSV.txt

Store Point in CRD File  Use Sta-Off as Desc

Round Station to the Nearest 10

Store Station and Offset in Note File

Note that the rounding is fully automatic. If you choose a 5-unit rounding, and are targeting station 0+75, but take a shot at 0+77.93, it will round up to 0+80.

Before collecting the cross - sections, it is important to click X-SCT Settings near the top of the dialog and set the stations you wish to capture. This way, if the station rounds, per the above screen, to a station that doesn't exist in your list, you are warned before proceeding with storing. This list also includes the left and right “tolerances” for the offsets, which will lead to warnings if you exceed that distance from centerline. If you set a tighter “Station Tolerance” in X-SCT Settings (option Edit) than the “Rounding” Tolerance, you will be warned even though the rounding is correct. In the screen shown below, station 16+70.000 has been added as a special station. Clicking the first line (10+00.000-23+00.000) allows you to set the standard interval, and the additional stations in the list would be for special stations in addition to the standard interval.



Station	Offset Left	Offset Right	Interval
10+00.000-23+00.000	100.000	100.000	50.000
10+00.000	100.000	100.000	50.000
10+11.570	100.000	100.000	50.000
16+70.000	100.000	100.000	50.000
23+00.000	100.000	100.000	50.000

Add Odd Stations   Edit   Remove   Save

The below, smaller dialog appears when you tap Add Odd Stations, shown in the figure below.

Add odd station		✓	✗
MIN Sta:	10+00.000		
MAX Sta:	23+00.000		
Station:	16+70.000	ft	
Left Offset:	100.000		
Right Offset:	100.000		

With the first line highlighted, selecting Edit leads to the settings options for the full range of stations.

X-SCT Settings		✓	✗
MIN Sta:	10+00.000		MAX Sta: 23+00.000
Range of Stations:			
<input type="checkbox"/> Do not use range of stations			
Beg. Sta:	0+00.000	ft	
End. Sta:	23+00.000	ft	Left Off: 100.000
Interval:	50.000		Right Off: 100.000
Offset from alignment to X-Section:			0.000
<input checked="" type="checkbox"/> Add Start and End Stations			
<input type="checkbox"/> Add PI, PC, PT, TS, SC, CS, ST Stations			



With an interval set of 50, and Start/End Stations turned on, the program will only expect you to capture stations at 50 unit intervals starting at 10+00 through to 23+00, but also including 10+11.57 and 16+70 in this case. The Offset from alignment to X-Section option lets you, in effect, use an alternate, parallel centerline at a left (negative) or right offset from the main centerline. Unless the Raw/Geodimeter method is used, a station “warning” screen is used if the rounded station is not in the list or pre-selected stations. A capture of station 1075 would round to 1080, but since 1080 is not in “the list”, you will be warned before storing. A station of 1667 would round to 1670, which is in the list, leading to no warning screen. Since the rounding was set to 10 in this example, data collected at 45 to 55 would round to 50 (station 1053 would not round up to 1055), and therefore only “even 10” stations will be collected to begin with. So, the additional “Station Tolerance”, which rounds the collected station data to the listed stations, will not activate.

When OK (green check mark) is clicked from the Store Sections dialog, the program immediately proceeds to a point collection mode, with continuous presentation of station and offset (if running GPS or robotic total stations).

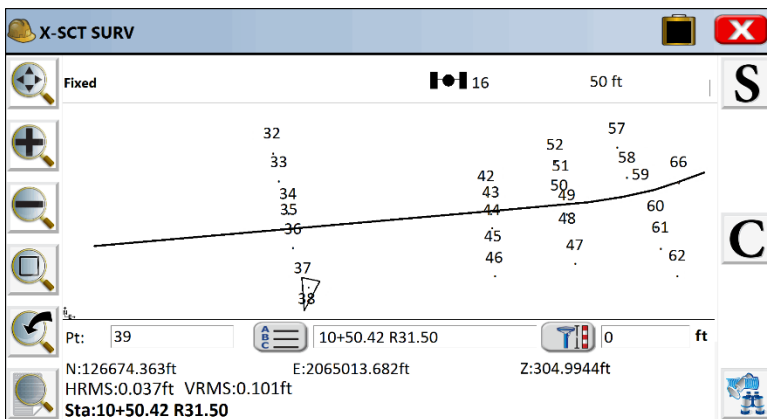

- **Storing Points using GPS:** There are two methods for storing points in real-time GPS mode: Press the S icon at right (or pick Alt S) or simply press Enter. The “binoculars” icon will bring up the Monitor/Skyplot dialog. You can survey as many cross - sections as desired within the command. Unlike in Slope Staking, Store Sections will respond to the setting for Hgt/Description prompt on save, found in Configure Reading, allowing you to arrow key to desired descriptions or change your rod height after taking the shot. Option C goes to the Configure Reading directly from the data gathering screen. When done, simply select the Menu button, and you are returned to the Road menu. When exiting by pressing Menu, if you have opted to store to an SCT file, you will be prompted to store the cross-section information in SCT form.



- **Storing Points using Total Stations:** After confirming the occupied station and backsight, as with all total station work, proceed through the same options above until you reach the store point dialog. In the example below, our centerline is metric, starting at station 0+000.

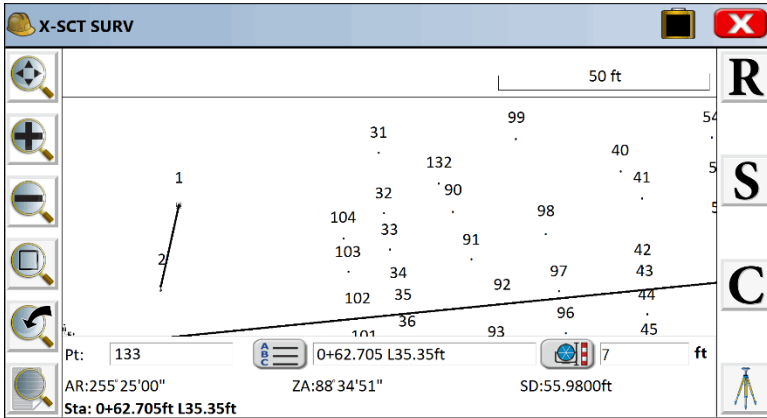

Here, your options are R for Read, followed S for Store, or simply Enter to Read and Store. The backsight icon can be pressed to set a new occupied point or backsight point. Note that we have a very “busy” screen of points. If you just want to see your setup, backsight and last point that was measured, press Alt F. This produces the screen below. You will stay in this mode until you press Alt F again and toggle back to the presentation of all points.

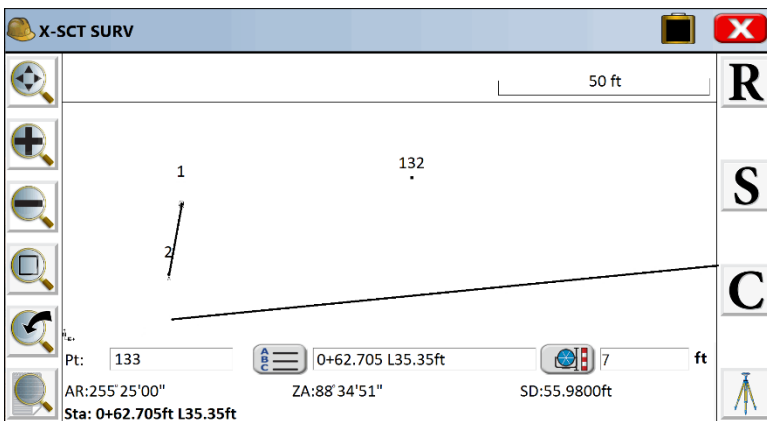





If a shot is taken that doesn't round to a station in the list of "approved" cross-section stations (X-SCT Settings), then a warning screen appears. In the warning dialog shown below, the tolerance has been exceeded on two accounts. We round to 0+80, which is not in the list, and our offset is 186.891 left, which exceeds our anticipated maximum offsets of 100 left and right.

**Station/Offset report**

Station Tolerance is Exceeded!  
Current Tolerance: 2.000ft

Edit Current Station    00+77.913

Round Station to the Nearest    10  
00+80.000

Use Closest Sta: 01+00.000    (Intvl.)

Offset is beyond the limits!  
Current Offset: Left 186.891

Offset Left: 100  
Offset Right: 100

Continue Storing

Points Store with Station/Offset Descriptions, as shown below:

29	0+125	L23.58
30	0+150	L33.24
31	0+150	L19.39
32	0+150	R1.98
33	0+150	R18.12

The comma-separated file would appear as follows if presented in a tab-delimited form:

#Point ID	Station	Offset	Elevation	Description
29	0+125	Left 23.5759	991.2901	0+125 L23.58
30	0+150	Left 33.2363	989.9193	0+150 L33.24
31	0+150	Left 19.3923	998.8921	0+150 L19.39
32	0+150	Right 1.9816	998.2340	0+150 R1.98
33	0+150	Right 18.1201	997.0731	0+150 R18.12

When you exit the routine by clicking Menu from the data gathering screen, and have Store SCT file turned on, you will be asked if you want to "process" or add the last shots you collected to the named SCT file. You have the choice to "Process" (use the data) or "Discard".

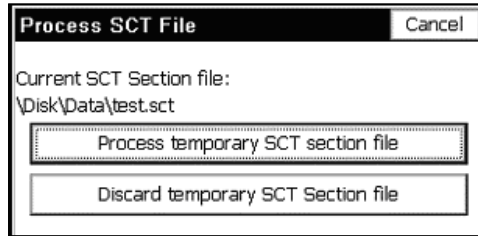

The program will even keep the section data “on file”, so that if you Cancel the above screen, and re-enter Store Sections, you will be prompted again whether to save (process) or discard the cross - section data collected earlier.

### Options When Storing in Raw/Geodimeter Format

Different options present themselves when the Raw/Geodimeter Format is chosen.

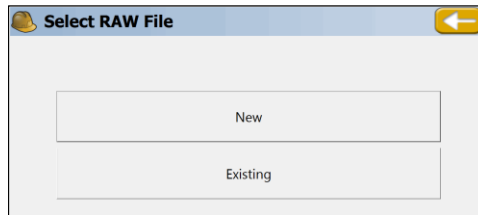

When Raw/Geodimeter is selected, a distinct set of screens are obtained. This particular format was adapted for highway departments and survey companies that had built cross - sectioning practices around the Geodimeter format. This method requires that you enter the station (chainage) being surveyed, and only uses the centerline position to advise you on your station and offset. A horizontal alignment is not required. The program detects the selection of this format, and before proceeding, opens with a starting screen where job-based information is entered.

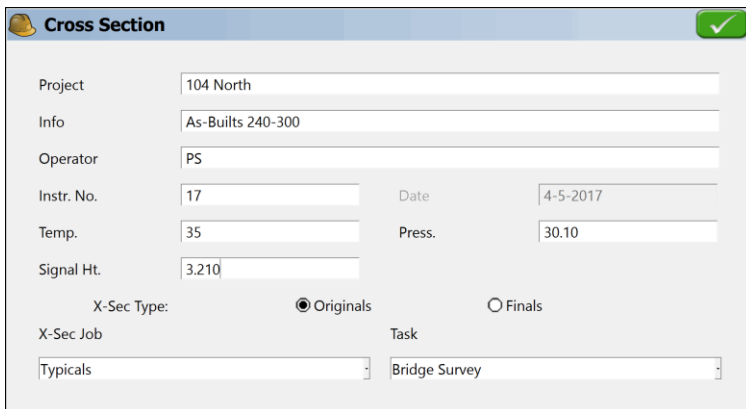



There are pre-set job categories and tasks, which save into defined number categories in the old Geodimeter raw file format. Whereas the SCT method recognizes the station you are on and automatically rounds to it when you are within tolerance, the Raw/Geodimeter method requires that you click the Station button and set your target station for collection of cross - section data.

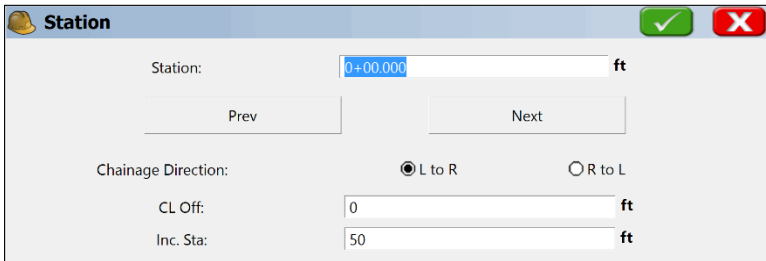
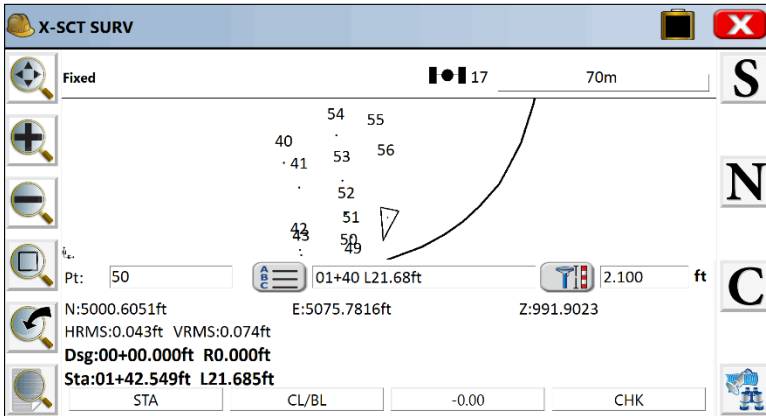

Then you proceed from the current location to the target station. In fact, although the points that are stored may contain station and offset descriptions, the data stored to the raw file pays no attention to the centerline information. The station and offset on the screen act only as a check on your current location. The direction of taking the sections, (L to R or R to L), is important and is set by specifying “Chainage Direction”. Unlike with the SCT format method, pressing Menu to exit does not store the data, but instead the data is automatically stored as you go, as a series of 37 (N), 38 (E) and 39 (Z) record types (Geodimeter format), with header line records, as shown below:

50=XSEC1  
54=104 North  
0=As-Builts 240-300  
53=VF  
90=2  
97=0  
51=3-28-2004



56=65.0  
74=30.10  
55=3  
96=2  
6=2.100  
80=280.000  
91=1  
37=5105.857  
38=5069.091  
39=991.905  
37=5104.091  
38=5074.931  
39=990.724

Starting left to right, the data points begin with a 91=1 record. A right to left section would begin with 91=2. When you “cross 0” or are on the centerline or baseline, you click the CL/BL button which sets a 92=1 record for centerline and 92=2 for baseline, and the next shot is the centerline/baseline shot. If you select the “-0.00” button, this indicates whether the next shot is a tie-in (catch) or extension beyond the tie-in. This sets a 93=1 record for the catch and 93=2 for the extension prior to the subsequent coordinate record. In effect, you tell the program where the centerline or baseline is by shooting that point. Then the station and offsets of the shots for that cross - section are determined relative to that center-of-alignment shot. It does not use a horizontal alignment combined with rounding to determine the station and offset of the shots (like the SCT method does). You tell it the station, the direction of measurement (left to right or vice versa) and you tell it which one is the center shot. This is why the Raw/Geodimeter method is the only method that works with no centerline (the “None” option). For each section, you tell it the station and center shot, and all other measurements are used to determine the left and right offsets relative to the center shot. If the L to R method was used, shots before the center shot are on the left, for example, and their offset is determined by the inversed distance to the center shot. The centerline file or other form of horizontal alignment, if selected, is academic and only used to advise you on your current station and offset. The CHK button will allow checking into known points to be sure that tight coordinate control is maintained. N moves onto the next station as defined by the interval set using the Sta button.

*Note: The SCT file method is the standard Store Sections method. The RAW/Geodimeter method is a flexible routine designed to adapt to customers who have built their cross - section processing systems around the Geodimeter raw file format.*



## 8.9 Stake Slope



The **Stake Slope** command calculates and stakes out the location of the “catch point” where fill slopes or cut slopes contact the original ground. The command will also set offset stakes to the catch point and will produce a report of the slope stake information. The location of the slope stake is dependent on the position of the “pivot” point where the slope begins and on the slope itself (e.g. 2:1, 3:1, 4:1, etc.). Slope stakes are typically used in highway work to locate the top of slope or top of cut. If design file information is available for the road template and profile, then the slope stake routine will calculate distance and offset information for all “break points” on the template from the slope stake itself back to the centerline. This also applies to slope staking conducted by section files, and descriptions associated with the break points on templates and/or sections are identified by name in the slope stake report.

*Note: Slope Staking can be conducted within the Stake Slope command from the fixed "pivot point" of the template, the end-points of cross - sections, or the centerline points of a horizontal and vertical alignment (as for a ditch). Slope staking, however, can also be conducted directly within the command Stake Road from any picked pivot point on the template or cross - section. One of the advantages of the Stake Slope command is the ability to obtain catch point information "real-time" using the "non-interval" method of walking parallel to centerline. Stake Slope will also automatically detect the ditch pivot point in cut scenarios using templates defined by Carlson Civil and Carlson Roads. Plus, Stake Slope knows which side of the centerline you are on and slopes stakes automatically to that side. The main advantage of Stake Road is the ability to slope stake from any picked point going either Left or Right as specified, for "staged" or partial roadwork design, or for finding catch points towards the interior of the template (e.g. central median). Stake Road also has a cross - section view option (within the Helmut Help). All slope staking is improved if the instruction to the user is In-Out from centerline and Forward-Back along the axis of the centerline. For this reason, it is best to set the View Point within FILE, Configure to In-Out and Left-Right, but also click on "Use Centerline for Reference Object".*

There are “rules” for slope staking. The slope stake is measured from a pivot point, which is user-entered, or starts at the centerline itself in “point-defined” alignments or starts at the last template point before the cut or fills when templates are involved or starts at the left and right end-points of sections when using section files. Note that in the command **Stake Road** (which works with both sections and templates), slope staking can be initiated from any desired point. This allows for slope staking of interior, central median catch points and slope staking of any side of an eventual divided highway, being built in stages. Slope staking can be interval based or accomplished based on where you are standing right now, independent of station interval.

Although office plans may predict the position of the catch points, slope staking is necessary to accurately determine the catch points based on actual field conditions. Slope stakes are often set at an offset to the actual catch points, since stakes at the precise top of slope or bottom of fill are likely to be knocked out by earthmoving activity. Furthermore, slope stakes are often marked with information on the slopes and distances in toward centerline or in toward the building pad or other feature. The



information on the slope stake is often written in “progressive” form: distance and slope from offset stake to slope stake, distance and slope from slope stake to outside shoulder, distance and slope from outside shoulder to edge of pavement, on into centerline. Thus, the slope stake, placed safely beyond the area of construction, tells the story of the cuts and fills in toward centerline or toward the center of the work.

Catch points for both cut and fill are shown in the typical section graphics below. See these two figures.

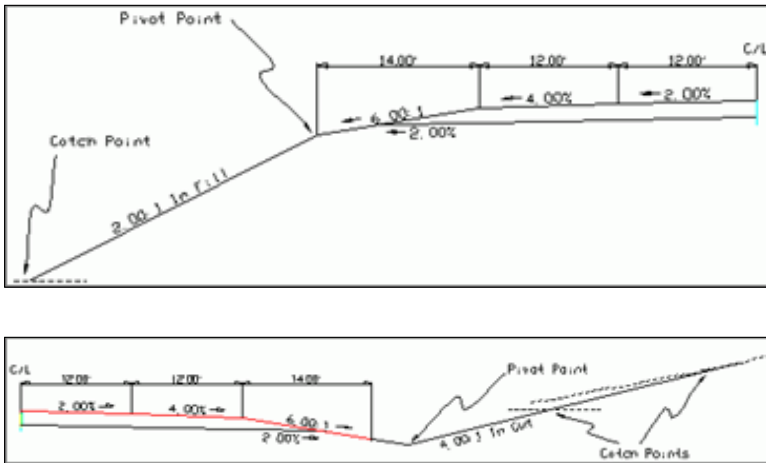

Note in the “cut” example above (bottom figure) how the catch point may be closer or farther from the pivot point based on the slope of the original ground. With flat ground at virtually the same elevation as the centerline of the road, the catch is found approximately 15 feet from the pivot point in the base of the ditch. But with ground sloping slightly uphill, it takes a full 30 feet or so to find the catch point. The program helps find the catch quickly by modeling the surface of the ground with each shot taken. Thus, by projecting the ground slope outward, the program advises the user how far to go to find the anticipated catch point. Unless the ground slope changes dramatically, the catch point is usually staked within just a few tries.



With GPS, the process is even more automatic, since the ground elevation is being computed continuously as you walk toward the catch point. No “shot” has to be taken until you are positioned right on the catch point itself. This next figure shows a cut condition slope stake in 3D. The “catch” is located at the top of the cut.

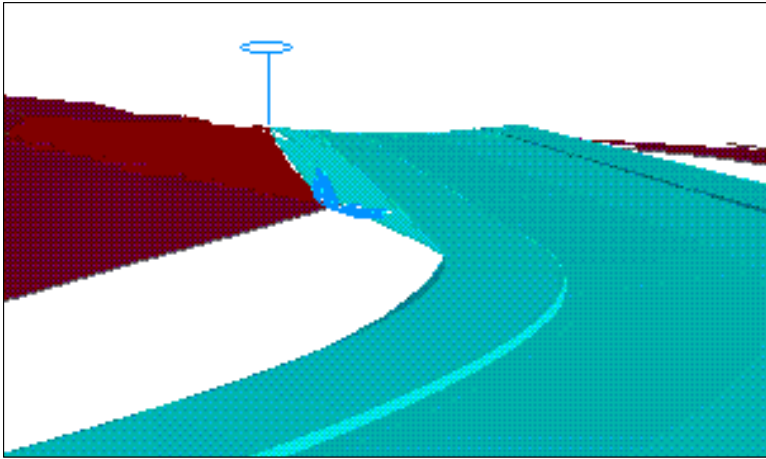

#### Four Methods of Slope Staking

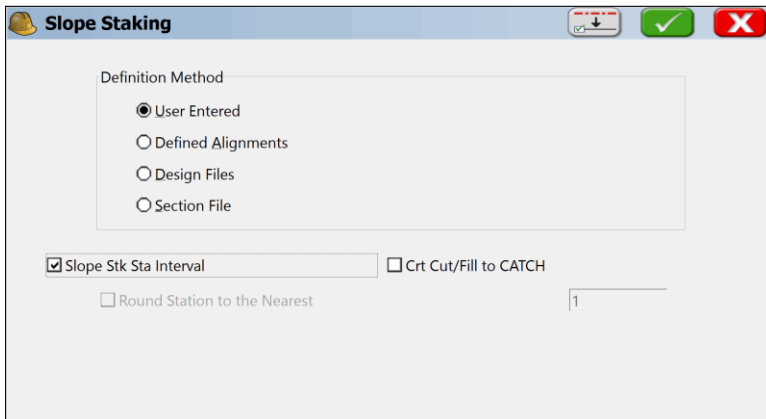

- **User-Defined:** This is the most commonly used method of slope staking. Here, you simply enter the station, offset and elevation of the pivot point. Do not enter a minus sign for a left offset as in  $-25$ , since the program detects whether you are left or right of centerline. The only prerequisite is the selection of a centerline file. Cut and fill slopes are entered in the field.



- **Point-Defined Alignments:** This method is often used for staking the top of cut for a ditch, particularly a V-ditch. You can select the centerline by any of the three classic methods of centerline file, a picked polyline on the screen, or a sequence of points. The vertical alignment can be derived from any picked 3D polyline or from the elevations on the sequence of points, or you can separately enter a profile. This method is useful for slope staking existing flow lines, where you simply take two shots at either end, create an alignment by point number, then set the slope stakes at the user-entered slope ratio.
- **Design Files:** This is the most “formal” way of slope staking, but typically only applies to uniform, simple road, drainage ditch or levee projects where the pivot offset positions do not vary from station to station. While all methods require that a centerline be selected, the design file method additionally requires, at a minimum, a template file and a profile (vertical alignment). For more complex roads, superelevation files and template lane width transition files may also be entered. With the exception of the centerline, profiles and simple templates, the other files are usually created at the office using Carlson Civil, Carlson Roads or TakeOff, and then downloaded onto the field computer.

*Note: Whenever the Road Design File option is selected, templates can be selected as a single “TPL” file, or as a series of templates organized as a “TSF” file (Template Series File). The TSF file can be entered within Road Utilities. If the left pavement lane of a road expanded from 10’ to 20’ for a passing lane, from station 1100 to 1200, you can create two templates, Road1 with the 10’ lane and Road2 with the 20’ lane. Then if you create the Template Series File shown below, the program will auto-calculate a 15’ left pavement width at station 1150. This same feature can be accomplished by using one template and applying a Template Transition File, which instructs on the changing dimensions of portions of a single template. Unlike the Template Series File, the alternate Template Transition File can only be created at the office using Carlson Civil, Carlson Roads or Carlson TakeOff.*

Station	Template
0+00.000	Road
11+00.000	Road
12+00.000	Road
20+00.000	Road





One advantage of the design files method is that since each template point has an “ID”, the slope stake report will include information to locate all ID’d template points from the slope stake back in to the centerline. In this way, the entire road can be built from the information marked on the slope stake, which is placed outside the construction area at a user-specified (e.g. 5’) offset to the actual catch point.

A report might appear as follows:

	HDIST	BDIST	SLOPE	
Offset to Catch	5.02	-0.17	CUT 3.4%	29.5:1
Catch to Pivot	32.20	16.10	FILL 50.0%	2.0:1
Pivot to Shldr	14.00	33	FILL 16.7%	6.0:1
Shldr to EOP	12.00	0.48	FILL 4.0%	25:1
EOP to CL	12.00	0.24	FILL 2.0%	50:1

The report might appear as shown here:

	HDIST	VDIST	SLOPE
OFFSET to CATCH	5.02	0.00	CUT 0.0%
CATCH to R651_5	87.24	43.62	CUT 50.0%
R651_5 to R651_4	10.66	5.33	CUT 50.0%
R651_4 to R651_3	6.00	2.00	FILL 33.3%
R651_3 to R651_2	4.00	0.17	CUT 4.3%
R651_2 to R651_1	3.99	0.17	CUT 4.3%
R651_1 to CENTER	10.00	0.43	CUT 4.3%

**Progressive or Total:** The above report is sometimes referred to as a “progressive” report, since it lists the incremental information from each break point to the next, going in toward the centerline. In some areas, the stake is referred to as a “story stake” or “progressive story stake”, because it tells the whole story of the gradework. The program is able to identify the names of the break points (e.g. “SHLDR” and “EOP”) because the templates used by the program must have pre-defined IDs for all break points. Specifically, with office-defined templates where cut conditions can have downslopes for ditches followed by upslopes, the program will auto-detect whether to pivot into fill or to create a cut condition, and pivot from the ditch line. You can also click the "Total" option and get offset distances to all break points as totals measured from the offset stake. In either case, the report is issued only if you stake the offset point to the catch.



- **Section Files:** Section files can be used to identify the pivot points left and right and minimize fieldwork. Consider the sections shown below.

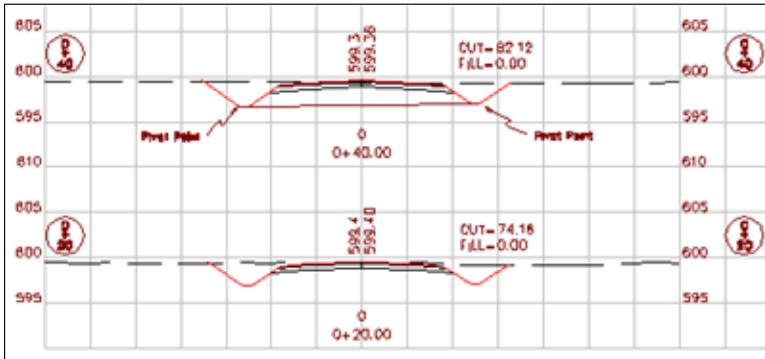

Shown are stations 0+20 and 0+40, with the pivot points for slope staking identified on station 0+40. For the section approach to work, the left-most point in the cross-section must be the left pivot, and similarly, the right-most point in the cross-section must be the right pivot. The section should only be entered from pivot left to pivot right (the “designed” catch points should be dropped). But since the interior section points have no bearing on the slope staking, they can be omitted, too. So, in the case of station 0+40, a 2-point cross-section could be entered, consisting of pivot left and pivot right. That 2-point section is also shown in the graphic above. It is just as effective for slope staking as a section containing all the break points between pivots. The one exception is if you have entered descriptions for your section points, you can obtain a progressive slope stake report, just as with the templates. Note that if descriptions do not exist, the report leaves them out. Section-based slope staking requires selection of a centerline file and field-entry of the cut and fill slopes.

Section-based slope staking is useful when the pivot points for stakeout vary unpredictably and don’t conform to a fixed template. Section-based slope staking has 2 advantages. First, all sections can be entered in the office as 2-point sections (left and right pivot), minimizing field paperwork and reference material. Secondly, odd stations can be staked out (e.g. station 0+27.5), since the pivot points can be straight-line interpolated by the program.

*Note: Section files can be used for slope staking within the command Stake Road. In this routine, you can choose sections or templates to stake, and you can pick any point to slope stake from—so any point on the section can become the pivot point. The advantage of slope staking by section file within Stake Road is that you can pick any point (greater flexibility). The advantage of slope staking by section file within the Stake Slope routine is that it automatically uses the left and right end points of the section as pivot points, which means less screen picks are involved (greater speed).*

Section files may be entered in Road Utilities, or in an external program such as Carlson Civil, Roads or TakeOff.



## Choosing the Slope Staking Method

When Slope Staking is selected, you are presented with a Definition Method screen, where you choose among the 4 methods of Slope Staking: User-Defined, Point-Defined Alignments, Design Files or Section Files. The application of these methods is discussed above.

The screenshot shows the 'Slope Staking' dialog box with the following settings:

- Definition Method:** Design Files (selected)
- Slope Stk Sta Interval
- Crt Cut/Fill to CATCH
- Round Station to the Nearest
- Input field: 1
- Buttons: Load Road Net File, Select Road Net Element
- Text below Load Road Net File: None

- **Slope Stake Station Interval:** When clicked on, your slope stake target is always a fixed point. It is the slope stake at the specified station in the input dialog in all 4 methods. But if clicked off, the slope stake target point moves forward/back station as you move. In User-Defined, the pivot offset and elevation is used regardless of station position. In the other methods, the pivot elevation is recalculated dynamically as you move based on the known information (3D points, profile, sections).
- **Round Station:** This option applies only if you turn off “Stake Station Interval” and move to “fluid” slope staking. If you “round” to an interval, such as 5, then the elevation to stake from is calculated to the rounded station value, as is the up-down station position for the offset. Rounding only applies to the stored report—the target still moves fluidly as you walk forward or back parallel to the alignment.
- **Load Road Net File/Select Road Element:** Carlson Civil 2008 and Carlson Roads 2008 have the option to output an "RNF" file, or "Road Net File", from the RoadNet feature. This file contains every centerline, cul-de-sac and road intersection "curve return" treatment for an entire road network. For example, a complete subdivision road system can be output as a single RNF file, and then SurvPC can stakeout any element of the RoadNet file that is loaded. Since the RNF file contains both templates and final sections, the Load RoadNet File option is accessible when slope staking by Design Files and Section Files. If you select, "Load RoadNet File", it merely loads the files, announces "Process Done" and all road files are placed into a temporary directory. You then need to click "Select RoadNet Element" to choose the element of interest. The three choices are centerlines, cul-de-sacs and the curve returns at intersections. For centerlines, the Center ID of the design template (if that method is used) is applied to the



horizontal alignment. Keep in mind that for cul-de-sacs and curve-returns, the position of the horizontal alignment is set in RoadNet within Carlson Civil and Carlson Roads, and typically is set to the edge-of-pavement alignment position. Slope staking will therefore use just the outer part of the template, for example, from EP ID outward, to find that pivot point. If you re-load the same RoadNet File, the program warns you that the prior temporary files will be erased and new ones created. This is done in case you actually modified a profile or other files in the temporary files, in which case you should use SaveAs in the appropriate command to preserve the changes in a new file name. When you Select RoadNet Element after loading an "RNF" file, you can highlight any element to stake, which then appear "dashed" when highlighted:

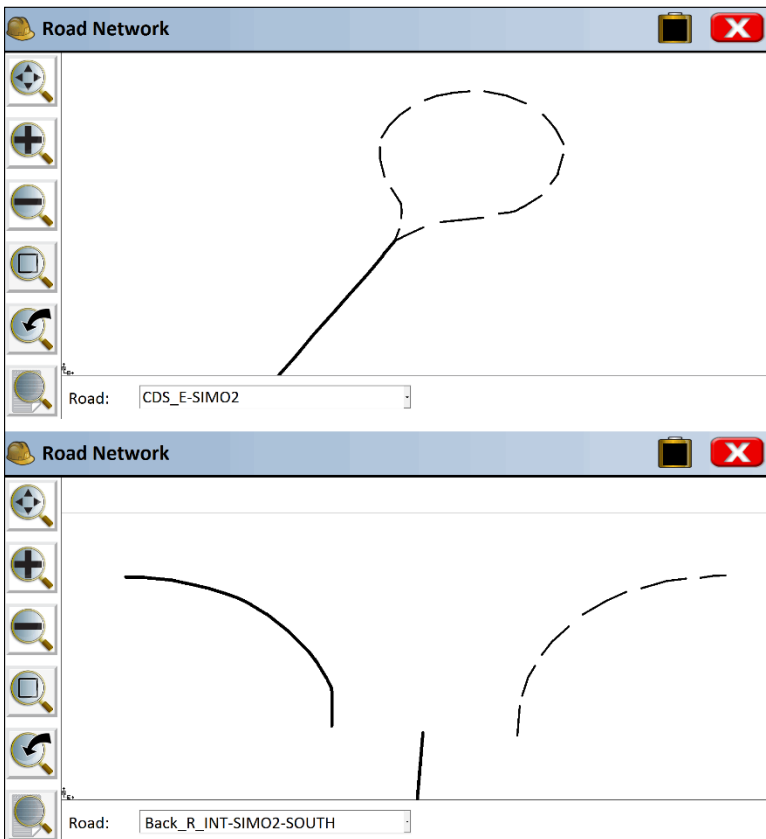

When you click out of the opening dialog that offers the 4 methods of Slope Staking, you obtain additional input screens.



- **User-Entered Dialog:** If the User-Entered method is selected, you are first prompted for a centerline, and a dialog appears.

**Station for Slope Staking** [✓] [✗]

Station:  Next Interval:

Pivot Off:  Pivot Elev:

Read Instrument

Use Point ID:  [Menu] [✗]

Slope:

Display As Ratio

CUT:

FILL:

At each station, you can enter a specific pivot offset, pivot elevation and the cut and fill slope ratio that governs. Slope ratios can be entered as percent as well, is "Display As Ratio" is clicked off. Pivot offsets should be entered as positive numbers even left of centerline, since the program will detect which side of centerline you are on from the first total station or GPS reading. The program will take the absolute value of the pivot offset entry, in any case. You can obtain the position to stake from "Read Instrument", which calculates the station, offset and pivot elevation from a measured position. Or you can enter a point number to obtain a station, offset and pivot elevation.



- **Defined Alignment Dialog:** The selection of the Point-Defined method leads to the classic alignment selection screen, familiar to users of Offset Stakeout and Stake Centerline.

The screenshot shows the 'Stake Slope' dialog box with the 'Horizontal' tab selected. The dialog has a title bar with a green checkmark and a red 'X' button. Below the title bar are two tabs: 'Horizontal' (selected) and 'Vertical'. The main area contains a sequence of steps: 1 Centerline File, 2 Select Polyline, 3 Define Point List, 4 Preview, 5 Edit, and 6 Save As. Below these steps, the following fields are visible: Centerline: C:\Carlson Projects\Data\DEMO.cl; Start Station: 0+00.000 ft; Ending Station: 3+08.327ft; Cutsheet: None.

The screenshot shows the 'Stake Slope' dialog box with the 'Vertical' tab selected. The dialog has a title bar with a green checkmark and a red 'X' button. Below the title bar are two tabs: 'Horizontal' and 'Vertical' (selected). The main area contains a sequence of steps: 1 Profile File, 2 Select Polyline, 3 Define Point List, 5 Preview, 6 Edit, and 7 Save As. Below these steps, the following fields are visible: Profile: C:\Carlson Projects\Data\DEMO.pro; Start Station: 0+00.000 ft; Ending Station: 3+08.000ft.

Though this is the classic use of the Point-Defined option (using points), slope staking can be conducted from a single centerline and single profile or from a picked 3D polyline. Points can be selected by number or picked directly off the screen.

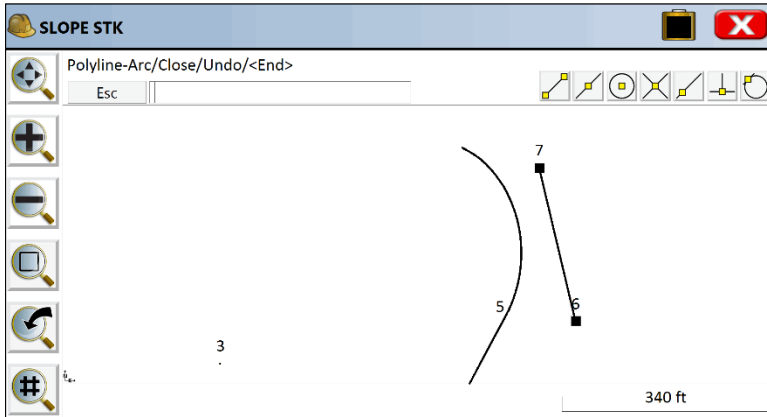

When a new horizontal alignment is selected by 3D polyline or point method, the program will ask if you wish to overwrite any existing vertical alignment selection. The typical answer is yes—you want it for both, and you are ready to stake any station at any interval based on user-entered slopes. Think of points 6 to 7 as the flow line of a ditch with steep side slopes, and the goal is to lay the slopes back at 2:1—a perfect application for Point-Defined Slope Staking.

- **Design File Dialog:** If you select Design Files, a dialog appears.

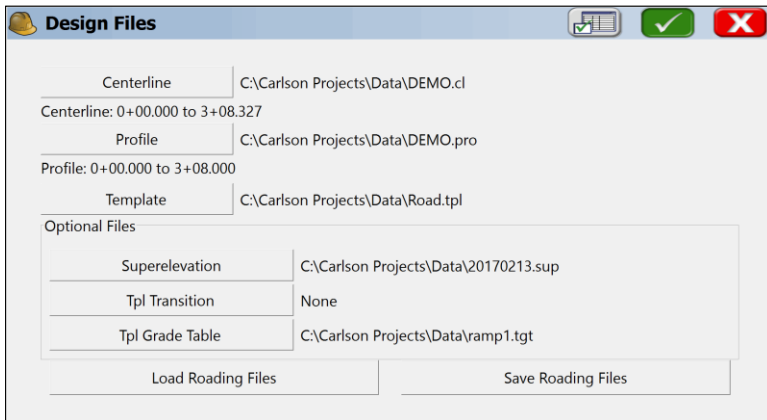

Centerlines, profiles and templates can be made using SurvPC. In fact, centerlines and profiles can be imported from a variety of file formats using the commands within Road Utilities. Note that templates can be either single template “.tpl” files or multiple templates with transitions in a Template Series “.tsf” file. If the roads have superelevation, the “super” files can be made in Road Utilities. If template transition files are to be used for lane changes, then this file type must be made using external software such as Carlson Civil or Carlson Roads. Note that “sets” of Roading Files can be saved and loaded using the buttons at the bottom of the screen.



The Settings icon at the top of the screen, to the left of the checkmark, allows you to place the profile grade at an offset to centerline, such as at the inside edge-of-pavement for divided highways, as shown below:

Settings

Apply Profile at

Left  Right

Fix Offset ft

Template ID EP

Reference Alignment

Vert Off of Profile:  ft

- **Section File Dialog:** If Section File is selected, a dialog appears.

Section File

Centerline C:\Carlson Projects\Data\DEMO.cl  
Centerline: 0+00.000 to 3+08.327

Profile C:\Carlson Projects\Data\DEMO.pro  
Profile: 0+00.000 to 3+08.000

Design Section C:\Carlson Projects\Data\DEMO.sct  
Sections: 0+50.000 to 3+00.000

Apply Vertical Alignment

Continue Last Slope

Cut:  Fill:   Display As Ratio

Load Rooding Files Save Rooding Files

The Section file (which has an “sct” file extension) can be entered in Road Utilities or imported from the LandXML format using Section File Conversion, also in Road Utilities. Note that for all roading design files, there is no requirement that starting and ending stations (chainage) match. All that is necessary is that they have a station range in common (in the above case, 10+00 through 20+00 is common to all files). Rooding File sets (as in the above Boneta files) can also be saved to a named set and then re-loaded later for convenience. With cross - sections, the profile is not required, but including the profile will lead to more accurate slope staking between known cross - sections, such as at high and low points in the road.

### Setting the Station and Interval for Stakeout





The next screen sets the station to stakeout and the interval and will appear in some form in all cases except section and design files slope staking with interval turned off. In effect, there are 8 ways of going into Slope Staking: 4 methods times 2 interval options (on=fixed station/off=fluid, real-time). You also have 3 more methods if you include the Stake Road routine which offers Slope Staking by Section, Template or Sections Cut from DTM, all fixed station.

Station for Slope Staking

Station: 6+00.000

Next Interval: 50

Read Instrument

Use Point:

The station to stake can also be read from the GPS or total station measurement, allowing you to slope stake "where you are". You can also get the station by entering a point number, in which case it projects the point onto the centerline to determine the station. In the non-interval method, the above screen does not appear. You slope stake wherever you are all the time and are freed of the constraints of staking a specified station.



The User-Defined and Point-Defined Alignment methods have their own pair of “follow-up” screens for the location to stake.

**Station for Slope Staking**

Station: 0+00.000 Next Interval: 20

Pivot Off: 0.000 Pivot Elev: 476.080

Read Instrument

Use Point ID: [ ] [ ] [ ] [ ]

Slope:

Display As Ratio

CUT: 2.00:1

FILL: 2.00:1

For flow line or V-ditch staking, a 0 pivot offset would be entered from the point-defined alignment. If the ditch were a trapezoidal ditch with a 2 meter bottom width, and the alignment was the centerline, each side of the ditch could be slope staked using a pivot offset of 1 (1/2 of the ditch width from center to pivot point).

Both the Road Design Files and Section Files methods go straight to the navigation (stakeout) screens if no interval is selected (Stake Station Interval turned off). The pivot offset is built into these methods based on the “rules” outlined earlier -- you stake from the pivot to cut or fill in templates, and from the extreme left and right points of cross - sections. With interval turned off, slope staking by "User-Entered" method simply asks for the pivot offset and elevation at the current location, and slope staking by point-defined alignment asks only for pivot offset, obtaining the elevation from the vertical alignment.

Slope staking cannot occur outside the station range of the horizontal alignment. If your horizontal alignment runs from station 0 to 308, you can't stake station -10, either by interval method (naming the station) or by the non-interval, fluid “where-you-are” method.

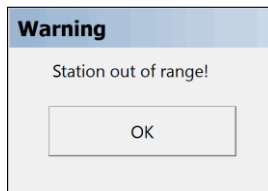



In live stakeout mode, you will get “Off Centerline” when beyond the range of the horizontal alignment.

All paths lead on to the navigation or stakeout (some call it “set out”) screen.

### The Navigation (Stakeout) Screen

When configured for GPS, the navigation screen then appears.

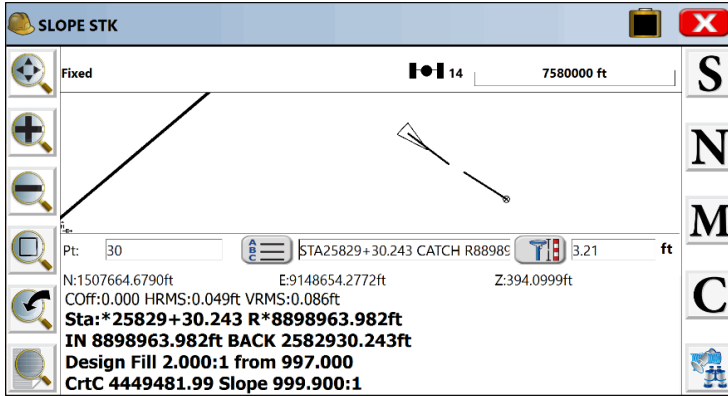

Note that because the GPS reads continuously and models the ground surface, the program calculates immediately where the catch point (the circle with the X) is located. You simply walk right to it. If the ground goes uphill or downhill as you approach the point, then the X will move closer or move away, until you are right on it.

As you get closer to the point (within the stake tolerance distance) the program will present a bullseye screen.

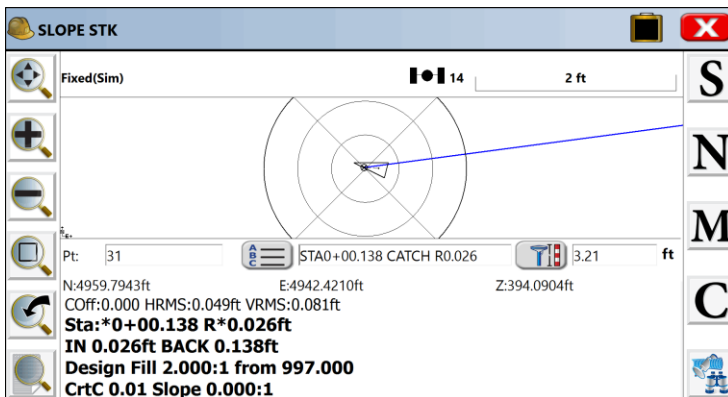



When you are satisfied with the accuracy of the slope stake position, you then touch S for Store (or press Enter to take the shot). In this case, it's time to drive the stake.

### Interval and Non-Interval Methods Impact Stakeout Screen

The stakeout screens above are for the interval method. In the non-interval, "fluid" slope staking, where you can drive the stake anywhere, the "Forward-Back" portion of the screen becomes vertical "Current Fill" or "Current Cut". In this fluid stake-out mode, you simply move in or out from the centerline to set the slope stake—there is no correct or incorrect forward or back station. So, the program instead reports the vertical up to the fill slope above you or down to the cut below you.

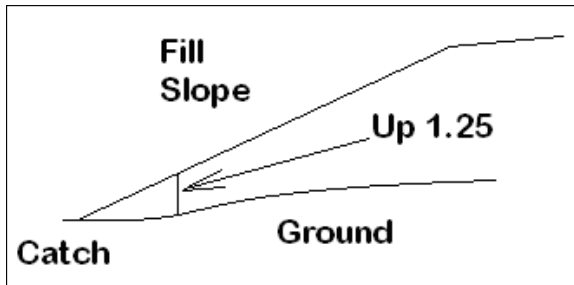

If you are moving out to the catch point along the ground, you would get a report of "CrtF 1.25" or some such number, and the "Current Fill" amount to the ground would decrease as you approach the catch. The actual stakeout screen would appear as shown below. Note that some surveyors will watch the lower line (1.6:1 for 3.65) and just keep moving out until they see 2:1 (or the desired slope) and drive the stake. Others will watch the "CrtF" value decrease to 0 and drive the stake, or watch "OUT" decrease to 0.



### Storing the Slope Stake and Offset Stake Points

When S for Store is pressed, you may store the actual slope stake point. You can also store a first offset point (since the slope stake itself can be removed by construction). The slope stake information is typically written on the first offset stake. Then you can also stake a second offset point, to obtain “line” to reset the slope stake if it is knocked out. The first and second offset stakes provide a direction back to the slope stake. When the slope stake is set, the program prompts for setting the first offset stake. When the first offset stake is set, the program prompts for setting the second offset stake. Both offset stakes are optional.

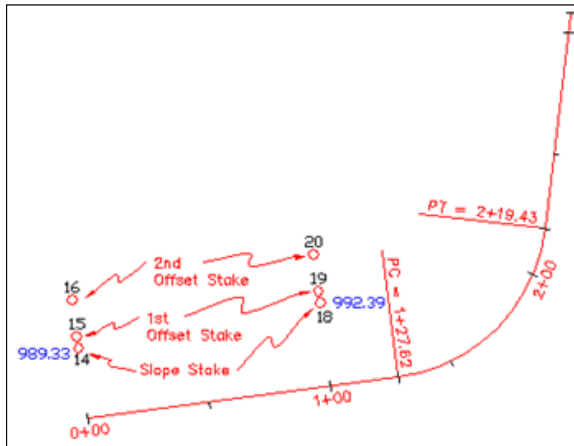

The storage of the slope stake points is an option turned on by clicking “Store Point to CRD File”. With this clicked off, you can simply slope stake and avoid storing any points. The Description for the point will default to the station and offset. Slope Staking will not respond to settings in Configure Reading for the Height/Description prompt screen. If you are using a named “Slope Stake File” (set in **File, Job Settings, Stake** tab, **Cutsheets** option), you can still control at the point of staking whether you choose to append data to the file by clicking on or off “Store Data to Report File”.



**Slope Staking Store**  Ref CL

	Station	<input checked="" type="radio"/> Offset	<input type="radio"/> Elevation	
Pivot Pt:	6+00.000	R18.000	945.750	
Catch Pt:	6+00.000	R36.501	955.001	
Stake Pt:	5+99.992	R36.478	955.001	
Stk-CP:	OUT 0.023		FWD 0.008	
Stk-PP:	C9.251	@1.997:1	HD: 18.478	50.063%
Stk-CL:	C6.251	@5.836:1	HD: 36.478	17.135%

Store Data to Report File

VOff:  ft Elv:  ft

Point ID:   Store Point to CRD File

GIS

---

**Slope Staking Store**  Ref CL

	Station	<input type="radio"/> Offset	<input checked="" type="radio"/> Elevation	
Pivot Pt:	6+00.000	R18.000	945.750	
Catch Pt:	6+00.000	R38.562	956.031	
Stake Pt:	5+99.298	R38.562	955.008	
Stk-CP:	F1.023		FWD 0.702	
CP-PP:	C10.281	@2:1	HD: 20.562	50%
Stk-PP:	C9.258	@2.221:1	HD: 38.562	45.025%
Stk-CL:	C6.258	@6.162:1	HD: 38.562	16.229%

Store Data to Report File

VOff:  ft Elv:  ft

Point ID:   Store Point to CRD File

GIS

Note that there are two options for the slope stake report: Elevation and Offset. The standard option is the Elevation method. This assumes you were able to survey the actual slope stake point with reasonable accuracy, and it reports the actual stake to pivot point results. If you were staking a 2:1 cut slope, it reports your actual slope (as 1.997:1 in this case), and you can choose to round the result and write "Cut 2:1, 9.25 V, 18.48 H" on the stake. But if at the catch point there are boulders in the way, you can walk out and away from centerline in cut and in toward centerline in fill and drive the stake where you can. In this case, you would choose the Offset method. In the Offset example above, we had to walk past the catch point about 2 units (from 36.50 to 38.56). We drive the stake and note that the catch is at 956.03 rather than 955.01, so we measure up 1.02 on the stake, and draw a horizontal line there as the catch point. An extra line appears in the report that tells us to write "Cut 2:1, 10.28 V, 20.56 H" on the stake. In cases of fill where there are obstructions, walk into centerline so when you drive the stake, you can mark where the fill intersects the stake.



When Enter or OK is pressed, you are prompted for whether to stake the first offset stake.

	Station	<input type="radio"/> Offset	<input checked="" type="radio"/> Elevation
Pivot Pt:	0+00.000	R0.000	997.230
Catch Pt:	0+00.000	R126.670	955.007
Stake Pt:	0+00.049	R126.726	955.007
Stk-CP:	IN 0.055	BACK 0.049	
Stk-PP:	F42.223	@3.001:1	HD: 126.726 33.319%

Store Data to Report File

Voff:  ft Elv:  ft

Point ID:   Store Point to CRD File

GIS

If you are doing “User-Defined” or “Point-Defined Alignment” methods, you are shown the horizontal distance and vertical fill or cut difference to the pivot point, which can be written on the Slope Stake. Additional break-point information appears if you are using the “Design File” or “Section File” method. If you trust that the Slope Stake will not be knocked out, then you are done—no need to set an offset stake.

Pressing OK leads to the prompt to set the first offset stake. If you choose to set the first offset stake, then you can set the offset distance.

Station:  ft

Offset:

Offset Type

CL Offset  Delta Distance from Catch Pt



Press OK and then you are in a standard stakeout screen. The offset point is a fixed location and the stakeout procedure is similar to point stakeout. This leads to a report of information that can be written on the Slope Stake. Finally, you will be prompted for staking out a second Slope Stake, to establish “line.” After the first offset stake is set, and before the prompt for the optional second offset stake, a summary screen will appear. If you have used the Road Design File or Section File methods, you will be presented with every break point into centerline.

	HDIST	VDIST	SLOPE	
OFFSET to CATCH	4.97	0.01	FILL	0.3% 34
CATCH to BD	17.00	8.50	CUT	50.0% 2
BD to EP	6.00	3.00	FILL	50.0% 2
EP to CENTER	12.00	0.00	FILL	0.0% 99

	HDIST	VDIST	SLOPE	
OFFSET to CATCH	4.97	0.01	FILL	0.3% 34
OFFSET to BD	21.98	8.49	CUT	38.6%
OFFSET to EP	27.98	5.49	CUT	19.6%
OFFSET to CENTER	39.98	5.49	CUT	13.7%

Finally, you will be prompted for staking out a second Slope Stake, a more rarely used option whose purpose is to establish “line” (the direction) from the first offset stake to the slope stake itself. This permits accurate replacement of the slope stake when it is knocked out by construction activity.

*Note: When using Road Design or Section Files in Slope Staking, setting the first offset point is the recommended procedure, as it produces the full report, referenced to cross - section and template IDs, for all break points all the way into the centerline point.*





### Procedure for Slope Staking with Total Stations

The procedure is nearly identical, except that you must press R for Read (or Enter) to take shots and allow the program to begin calculating the Slope Stake position. Unlike the GPS, SurvPC cannot predict the location of the target slope stake point until at least one measurement is taken.

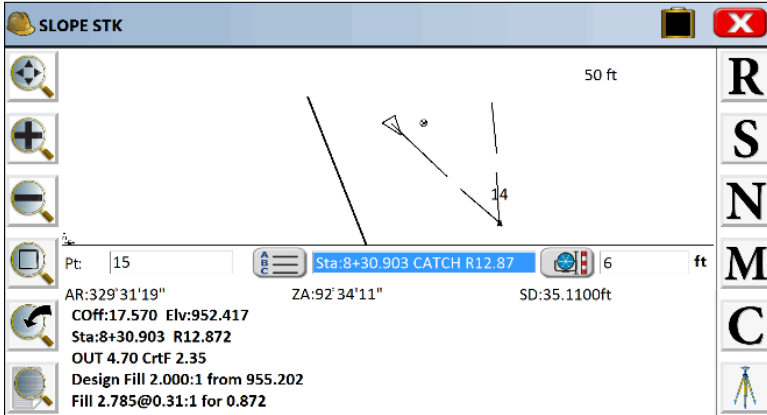

*Note: When using either GPS or total stations for slope staking, you can obtain more graphics and less screen information by pressing the down - arrow key. It literally has the effect of bringing the graphic screen down (see below). Pressing the up - arrow key will pull the screen back up and show the full text. This works in all modes except GPS Simulation, where the up - arrow moves the cursor faster, down - arrow slower.*

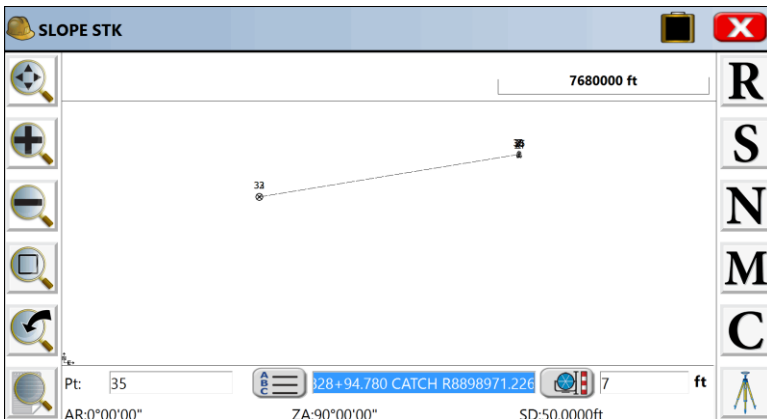



## The Slope Stake Report and Writing on the Slope Stake

Surveyors doing slope staking have the option to write the information on the stake as each is surveyed, or to come back at a later time, refer to the slope stake report, and write on all the stakes after the surveying is complete. The slope stake report file is a comma-separated “.txt” file, configured in **Job Settings, Stake, Cutsheets**, which might appear as follows if formatted in Excel or another spreadsheet form:

#Des Sta	Des Off	Des Elv	Staked Sta	Staked Off	Stake Elv	Desc
1+00.000	L33.849	998.075	0+99.966	L33.453	998.075	Catch Point
1+00.000	L38.849	--	1+00.019	L38.866	998.15	First Offset Point

Here is another example as viewed in the Edit mode within Job Settings, Stake, Cutsheets, Edit Slope Stake.

Design Sta(ft)	Pivot Off(ft)	Elev: PP/CP(ft)
7+00	Right 18.0	947.75
OFFSET to CATCH	H0.00	V0.00
OFFSET to BD	H14.49	V7.24
OFFSET to EP	H20.49	V4.24
OFFSET to CENTER	H32.49	V4.24
7+50.00	Right18.0	949.50
OFFSET to CATCH	H0.00	V0.00

The columns are configurable with the Slope Stake formatting in Job Settings. Shown above is a "total" report (as opposed to "progressive"). No offset stake was set. The template involved was flat from centerline for 12', then had a 2:1 slope for 6' into a ditch point (ID="BD" for "base of ditch"). This cut downslope condition was created within an office-entered template using Carlson Civil or Carlson Roads, and SurvPC automatically detected the cut condition and used the ditch points as pivot points, offset 18 with elevations 945.75 at station 6+00 and 946.50 at station 6+50. Some survey teams use one person to set the slope stakes and another to enter data on the stakes, which is easily done using the stored slope stake report above.



## 8.10 Stake Road



Stake Road is one of four major commands used in highway work. This command is designed to stakeout specific stations and offsets along a centerline and can be used for slope staking. For example, if your goal is to stakeout the break points like edge-of-pavement and shoulder at station 87+80 on a given road centerline, you would use **Stake Road**. **Stake Road**, therefore, is used primarily to lay out road surfaces for construction. **Stake Road** is typically used to set cut and fill stakes or “blue tops” at specific stations and offsets. The elevation used to determine the cut or fill at each offset is derived from either design files (the template interacting with the profile and centerline) or from cross - sections or from sections that are “cut” from alignments. The "Road Model File" option loads a LandXML file containing alignments for each break in grade, such as edge-of-pavement, shoulder and ditch lines. In each case, at any specific station, you will be guided to the desired offset and will get a cut or fill. By contrast, if the goal were to simply set random cut and fill stakes along an alignment, at no particular station or offset, then the command **Elevation Difference** would be used. If the goal is to stake out the “catch” in cut and fill, where cut slopes and fill slopes meet existing ground, then **Stake Slope** would be used. However, you can also Slope Stake within **Stake Road**, with the advantage of having the option to see both a section and plan view. **Stake Slope**, by contrast, has one advantage over Stake Road in that it can slope stake at any position, and does not require a station to be specified. The fourth, major highway-oriented feature is Store Sections, which is used to gather “as-built” information on a road. In this command, you take cross - sections of data points along the road, at random or specific stations. In summary, **Stake Slope** starts the cut and fill work, **Stake Road** directs the precise roadbed work and fine grading, **Elevation Difference** acts as a quick grade check, and **Store Sections** produces the final confirmation of the as-built road for payment and certification. It is highly recommended for all road stakeout that you set on "Use CL for Reference Object" within **Configure, View Point** tab.

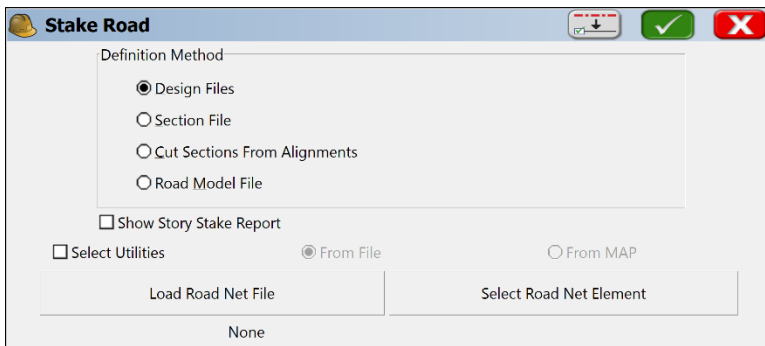



-  **Reference Centerline Button:** In the opening screen, the button up top, left of the green check (OK), is the "Reference Centerline" button. This button allows a second centerline to be used for instructions on forward and back, Left and Right to stake the point calculated from the primary, first centerline. This is useful when the primary centerline is curving and where a single point may be offset from different positions along the centerline. The second, reference centerline is usually the main road centerline, so that forward-back, left and right instructions are easy to follow. Because this feature is rarely used, its very appearance is configurable. You must turn it on in **File, Job Settings, Stake Tab, Alignment Settings, Option "Allow Reference Centerline"**. If checked, this means a reference centerline will be used for the road options Design Files, Section File and Road Model File. Note that if the reference centerline is on, but carried forward from another job, you might obtain extremely large station and offset data, possibly with negative numbers. The reference centerline station and offset data is always presented with an asterisk (\*), so if you see the asterisk followed by clearly erroneous data, look to see if the reference centerline has been left on, pointing to an incorrect centerline, and turn it off.
- **Story Stake:** The middle zone of the opening screen in Stake Road shows the 4 methods of defining the road, described below. Underneath the method options is the option to turn on "Show Story Stake Report". If this is selected on, then ANY point that is staked out on the road will lead to an entire report on all breaks, starting on the far outside of the section on the side you are on, to the point you staked, then past that point all the way to centerline, as shown below. Note that your current staked position is SHLD1, so since this is on the right side of the road, the first page of the report and the first line of the second page shown cover distances to offsets further to the right, and the lower portion of the second page cover distances from your staked position in to centerline. You can also see the relative cut and fill and distance to the break points on the other side of the road if you click off "Show Report up to CENTER". Then the report would be even longer! Similar to the Slope Stake Report, you can see the progressive horizontal and vertical distances or the total to your current, staked position. Although it is standard to do these reports and mark slope stakes, the Story Stake allows you to mark ANY stake, not just the slope stakes on the outside of the road, but, for example, mark all information on a central depressed median stake, which the contractor can then reference. The Story Stake report applies to all Stake Road methods.
- **Road Network (.rnf) Files:** The Carlson Civil module of the Carlson office software has a command called Road Networks that will output both design files and cross - section files for street intersections and cul-de-sacs, in addition to main alignment segments of the road. The breakthrough feature allows for staking out of complex intersections, including what are sometimes called the "curve returns" where the edge-of-pavements and other breaklines, in effect, are filleted with inscribed curves. The multiple curves of cul-de-sacs can also be output. It is



highly recommended that when Road Network Files are used, you should select the Section File method of stakeout within Stake Road. The outputting of Road Network files is found within Settings in the Road Network command in Carlson Civil, as shown below as "Write SurvPC Stakeout":

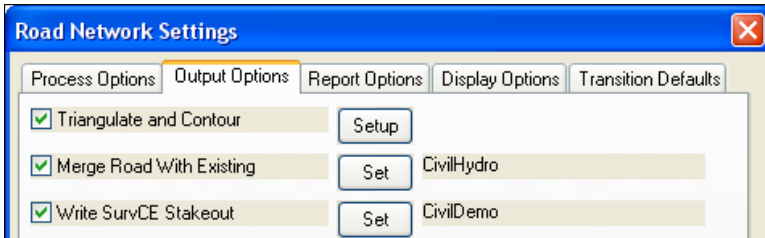

## Defining the Road

The first dialog that comes up when you select Stake Road is where you define the road by selecting one of the following options.

- **Design Files:** In Carlson SurvPC, design files include templates, centerline, profile and optionally, superelevation and template transition files. If you wish to “clear” a file such as a superelevation file, just click it and choose Cancel. The definitions for each of these files is covered in their own sections of this manual. Design files are recommended for subdivision streets, access roads and simpler highway designs. The Template Grade Table file which can be input and edited under Road Utilities also is used as a "design" file and replaces the need for template transition and superelevation files, covering both options by specifying cross slopes and grade widths across any station range for any template ID.

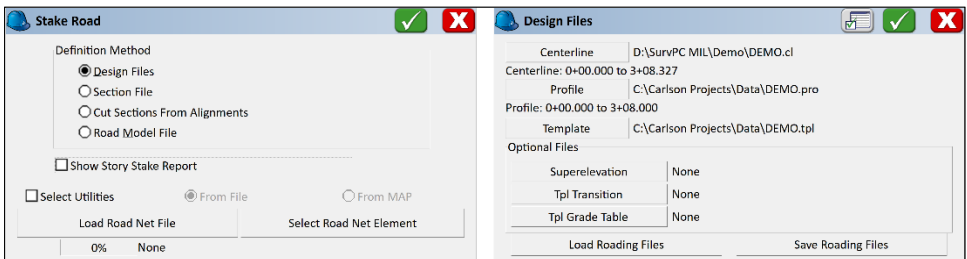



- **Section Files:** Sections are made up of simple offsets and elevations that can have optional descriptions such as “EOP”, “DL” or “SH” and must be accompanied by a horizontal alignment file (centerline). The vertical alignment or profile is optional but improves accuracy at high and low points. Every cross - section is a “snapshot” of the template at a given station. SurvPC supports using multiple surfaces simultaneously in Stake Road by using multiple section files or by extracting the section for each surface when all surfaces are within a single file (as exported by Carlson Civil). Each surface can exist on its own layer with its own color for easy identification while in the Stake Road dialog. For complex designs, with non-conforming intersections, transition lanes, special ditches, etc., it is recommended to use cross - section data if available. Longitudinal pipes can also be displayed in cross - section and staked out. The software now allows user definable horizontal and vertical offsets. These can be applied to North or South bound auxiliary centerlines.

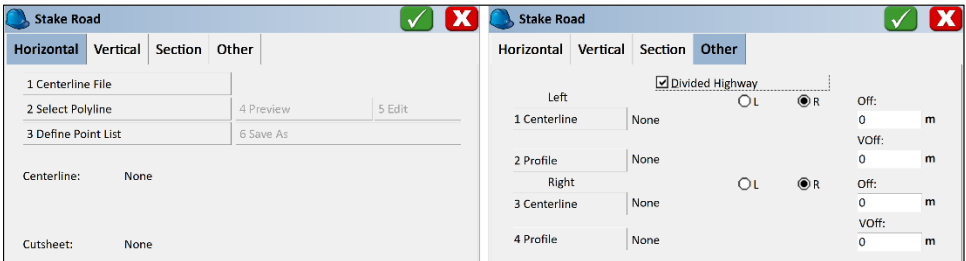

- **Cut Section from Alignments:** Provides the ability to extract cross - sections directly from 3D polylines that exist within SurvPC. The first thing you need to define is the horizontal and vertical alignment files. These form the basis for cutting the sections and determining left and right offsets from the horizontal alignment or centerline. The centerline-defining screen is similar to the screens found in Stakeout Line and other commands.

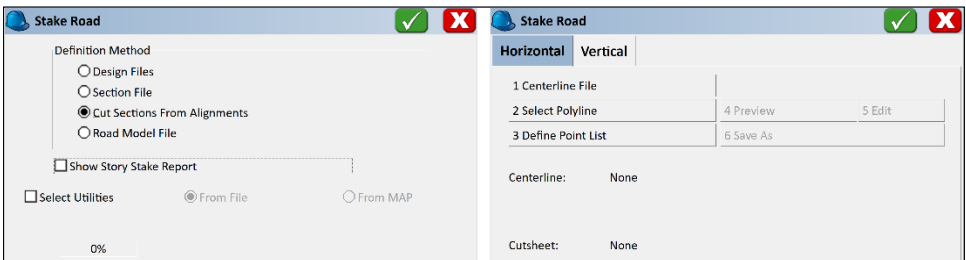



- **Road Model File:** Loads a LandXML "model" of all alignments associated with the road. Each "break point" on the road such as centerline, edge-of-pavements, shoulders and ditch lines can be considered to have its own horizontal and vertical alignment. By including all of these files in a single LandXML file, and by user selection of the true centerline for stationing purposes, the entire road can be defined in the form of a multi-alignment LandXML file. This method is commonly used in Scandinavia, the UK and by some U.S. Departments of Transportation.

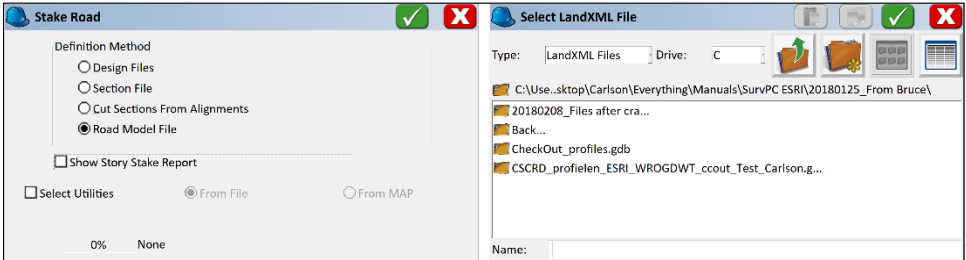

## Design File Method

**Design File Example Demo:** Provided with SurvPC and SurvPC are sets of roading files called Demo.cl (centerline, horizontal alignment), Demo.pro (profile, vertical alignment) and Demo.tpl (template). In SurvPC, these are known as "design files" for road work. In particular, the template is a rule-based design file controlling grade cross slopes, and including definitions for road lanes, curbs and cut and fill slopes. This template approach is best for simple roads such as subdivision and building access roads where rules are strictly followed (except at intersections). For intersections and cul-de-sacs, Road Network Files (.rnf files) from Carlson Civil can be used for stakeout (best done using "Section Files"). Design Files can be acted on by template transition files (which expand and contract road lanes), by superelevation files (which alter cross slopes) and by template grade table files (which both change lane dimensions AND cross slopes). Here is an example of a simple road. You can follow along using the 3 "Demo" files (.cl, .pro and .tpl).

Begin by starting a job named Demo. It does not matter whether you are in metric units or feet. If there are any points in the file, go to Cogo, Keyboard Input, Utilities and delete all points by range (or enter ALL). You can delete any points one-by-one using File, Points, highlight and delete. Now draw the Demo.cl centerline using the command, in the Map screen, under Tools, Centerline, Draw CL to Map. Then use Cogo, Create Points, Polylines to Points to turn the centerline into points at all vertices and radius points. Start numbering at point 1.

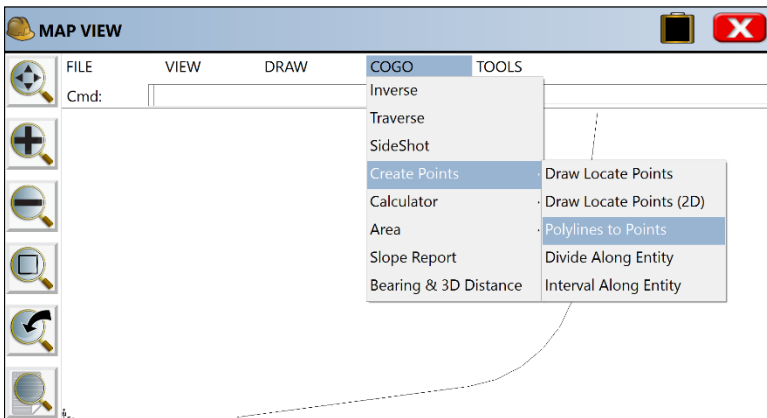
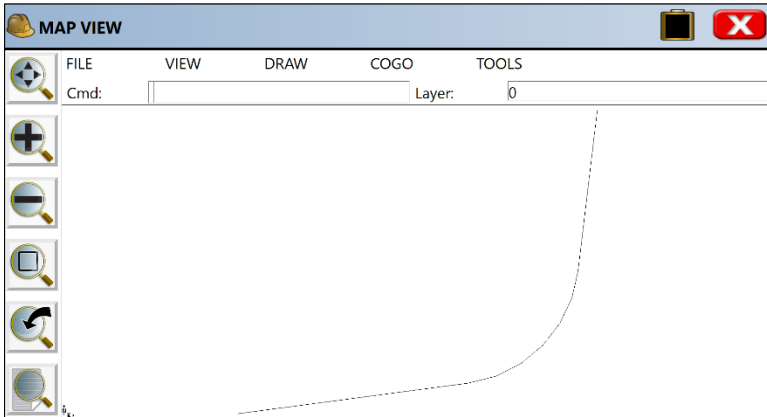
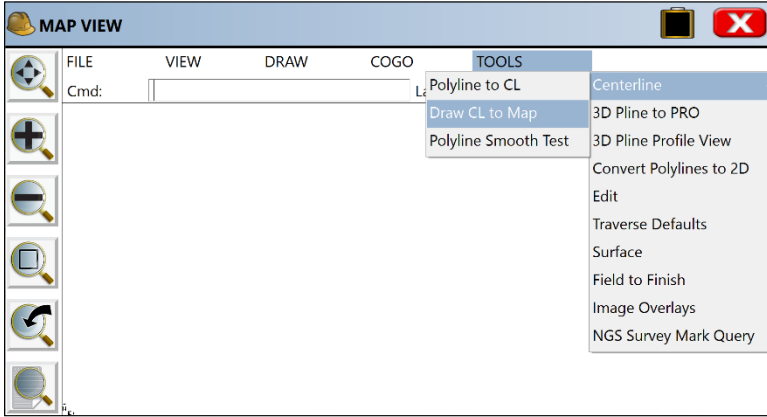



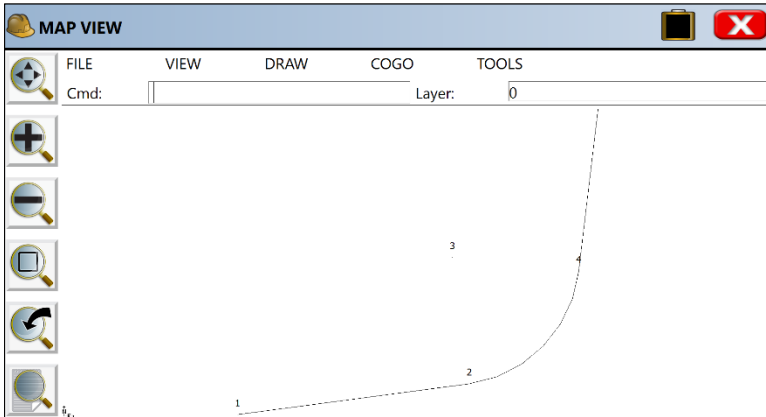

The next step is to go to Road, Stake Road, be sure no reference centerline is selected (button at top of screen) and select Design Files. To turn off any of the 3 files in the lower, optional section of the dialog (lower left), click those items and remove file using Cancel (red X). Note that the stationing of the centerline and profile do not need to match--they just need to have areas of overlap to work. In this case, the end station nearly matches perfectly (308.327 vs 308). So, you could not stake out station 308.1--there is no extrapolation on the vertical alignment. You will be warned, "No Cross - section..." if you enter 308.1 to stake.

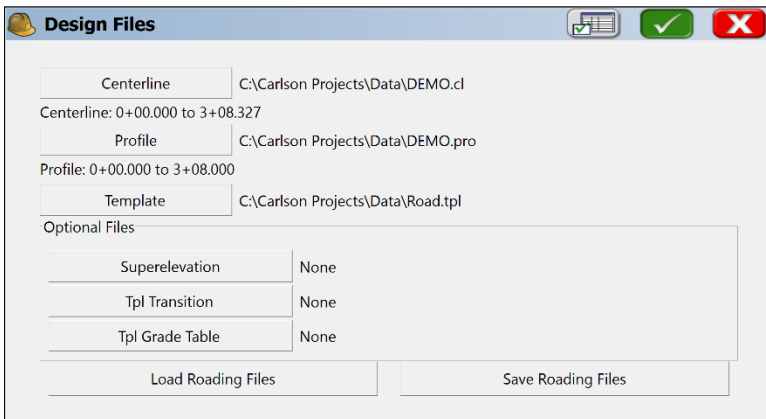

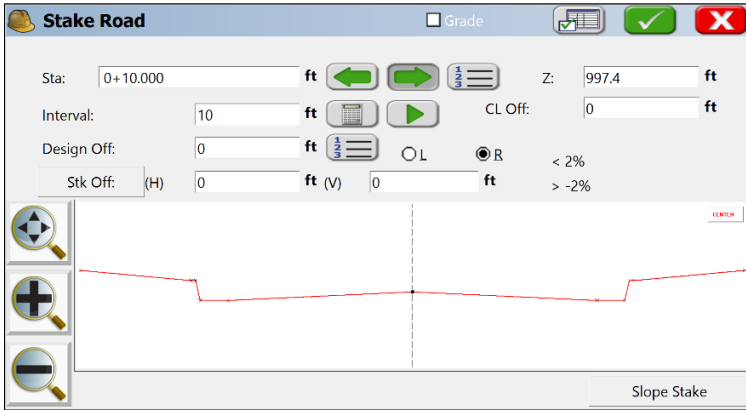

The settings button in the Design Files screen allows application of the profile to any template ID--the default is "Center" or center of road. For divided highways, the profile grade is often the inside edge-of-pavement, rather than the center (which might be a concrete median or central ditch). The settings button in the Stake Road dialog above goes to the standard, 3-tab Road Stake dialog also accessible in Job Settings, Stake option. This controls various things such as vertical exaggeration (here 4x was used) and key station points to increment through (e.g. PC, PT, high points, low points). Select a Design Offset of 0 by entering it or picking the middle of the template (zoom extents to center the template). Set a Stake Offset H=0 and V=0. Note that the slope into the selected point (left of center) is displayed as 2% and the slope right of center is displayed as -2%. Slopes in this display are calculated left to right, not outward from centerline (in which case both slopes would be -2%). Select any point on the template to stake, either graphically by picking or by entering a point. If you pick graphically, you must pick a template "break point", indicated by the X's. All template break points have template IDs like EP for Edge-of-Pavement and SH for Shoulder. If you enter an offset, you can select a point that is not a break point, such as 5.5 Left (shown below):

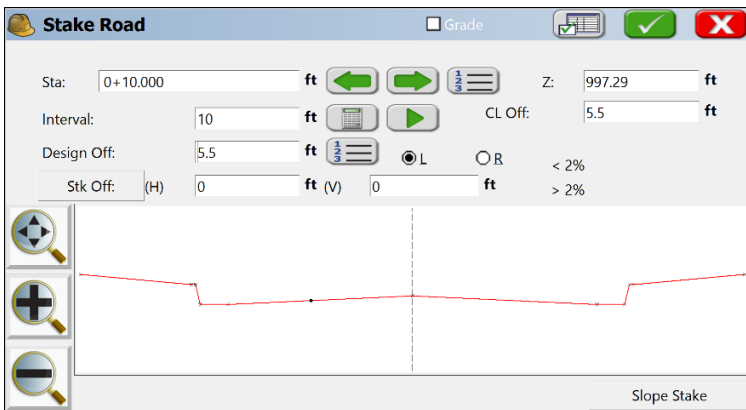



**Stake Road**  Grade

Sta: 0+10.000 ft    Z: 998.06 ft

Interval: 10 ft   CL Off: 22.1 ft

Design Off: 18.1 ft   L  R

Stk Off: (H) 4 ft (V) 0.16 ft

Slope Stake

If you click OK, you begin the stakeout process (requiring Localization if running GPS Simulation). Another option is to stake an offset. Click on the far-left template point (SH) and then enter an offset of 4 units. Then if you want to extend the slope of the last segment, click the "Stk Off" button, choose Extend Current Slope option, and return back to the above right screen. Note the vertical offset is calculated for you (you can always direct enter the vertical offset if you know it). Also, note as you make these various changes to the target point to stake, the Z elevation in the upper right of the screen is re-calculated and the target "CL Offset" distance is displayed, which is now distinct from the Design Offset. When ready, click OK to stake out.

### **Design File Example with 4% Cross Slope Superelevation using Superelevation**

**File:** Let's say the road goes through a superelevation of 4% at the PC at station 127.62 and complete superelevation of 4% at the PT station of 219.62, transitioning from normal crown to full super in 90 feet (e.g. 37.62 start transition, pivot from -2% to 2% on outer lane to "reverse crown" at 97.62 and reach 4% full super at 127.62). In this way, the rate of transition of the outside lane on the curve left is 2% each 30 length of road. Complete the same transition in reverse after the PT, from 219.62 at 4% to 249.62 "reverse crown" (2% slope both lanes) to 309.62 end full super. This can be accomplished by 2 methods: (1) Superelevation Files applied to a single Template or. tpl file or (2) by (Template Series Files--using 3 templates: normal crown, reverse crown and full super). It is very important to first define the template ID point outside of which no superelevation rules are applies. If you have a curb and gutter road, usually the edge-of-pavement (EP in this case) is the outside lane to apply the superelevation--all template points beyond that follow their original definition, including the 4% uphill shoulder slope, even when in superelevation.



**Input-Edit \*.tpl File**

C:\Carlson Projects\Data\DEMO1\_.tpl

GRADES:  Right Side Same as Left

Left SURFACE			Right SURFACE		
Distance	Slope	ID	Distance	Slope	ID
10.000	-4.000%	EP	10.000	-4.000%	EP
0.010	2.000	CB	0.010	2.000	CB
6.000	4.000:1	SH	6.000	4.000:1	SH

Add Edit Remove Up Down

Cut/Fill Super Load Save

**Super Elevation Settings**

Divided Road

Transition from Normal to Super(Inside Edge)

High Side PP:  Low Side PP:

Transition from Normal to Super(Outside Edge)

High Side PP:  Low Side PP:

Max Percent Slope Difference:

Low Side Grades to Match Greater SUP Slope:

Now to accomplish the above superelevation by use of a superelevation file, enter the following within Road, Utilities, Input-Edit Superelevation Files:



**Superelevation List: Demo**

Beg Trans	Run-In	Norm Out	Run-Off	End Trans
0+37.620	0+67.620	2+49.620	2+79.620	3+09.620

Add Edit Remove Clear

EQ Load Save As

**Add Super (Stations):**

Begin Transition: 0+37.620 ft Begin Run-In: 0+67.620 ft

Reverse Crown rate in: 0+97.620 ft

Grade Slope(%): 2.000 Design Speed: 35.00

Curve Type:  Spiral  Circular

Max slope of Full Super(%): 4

Begin Full Super: 1+27.620 ft End Full Super: 2+19.620 ft



Reverse Crown rate out: 2+49.620 ft

Reverse Curve End Run-Off: 2+79.620 ft End Transition: 3+09.620 ft

Note that 3 transition points are defined: (1) begin transition, (2) run-in and run-out where the pivoting outer lane side has a zero cross slope), reverse crown and full super. So, between these 3 transition points, the rate of transition may vary. In this case the rate is the same, 2% every 30 units of length on the outside lane. This entry creates one line of superelevation, one for each curve involved.



When this is applied, note cross slopes at stations 67.62 (2% and 0%), 97.62 (2%) and at station 127.62 (4%) below:

**Design Files**   

Centerline: C:\Carlson Projects\Data\DEMO.cl  
Centerline: 0+00.000 to 3+08.327



Profile: C:\Program Files (x86)\SurvCEDemo\Data\demo.pro  
Profile: 0+00.000 to 3+08.000



Template: C:\Carlson Projects\Data\DEMO1\_tpl



Optional Files

Superelevation	C:\Carlson Projects\Data\Demo1.sup
Tpl Transition	None
Tpl Grade Table	None

Load Rooding Files Save Rooding Files

**Stake Road**  Grade   

Sta: 0+67.620 ft    Z: 999.705 ft

Interval: 5 ft   CL Off: 0 ft

Design Off: 0 ft   L  R < 2%

Stk Off: (H) 0 ft (V) 0 ft > 0%

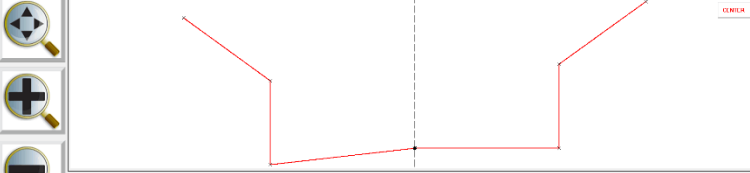

Slope Stake



Shown below are the reverse crown and full super sections at station 97.62 and 127.62:

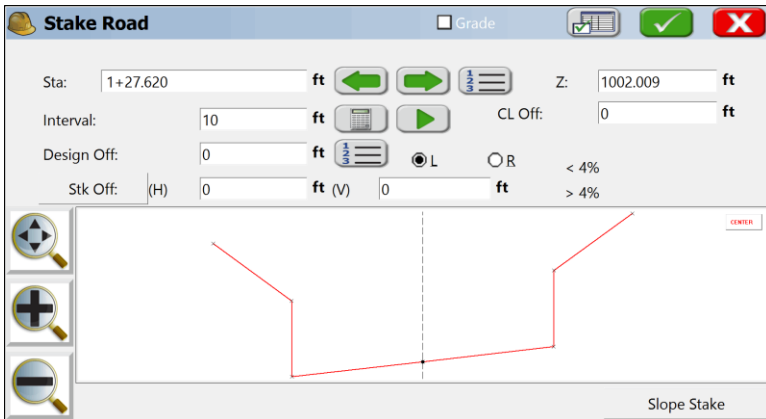
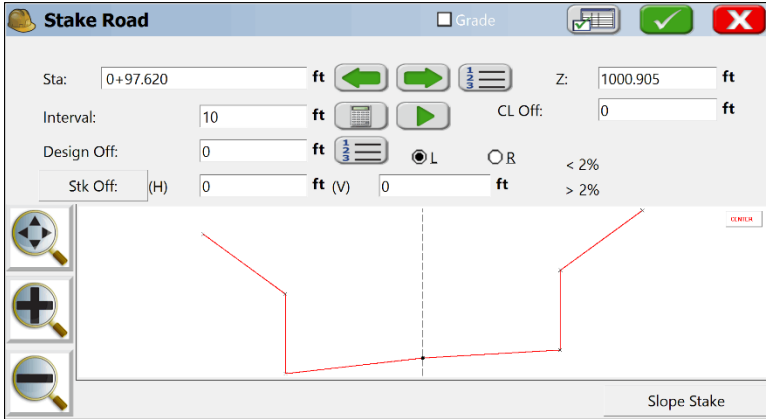



**Design File Example with 4% Superelevation Plus Lane Width Changes using Template Series (.tsf) File:** Another way to accomplish lane-controlled superelevation is to use distinct templates, linked together as a "Template Series" file. In addition to the standard 10 width road at 2%, add another template for the reverse crown condition and a third template for full super. You need all three, since there is no slope change on the low side until reverse crown at 2% (same slope L and R) is achieved, at which point both sides pivot to full superelevation. We choose to do a second reverse crown template of 8 width to illustrate that you can also change the lane width on any of the additional templates, for a simultaneous reduction or expansion in lane width through superelevation. Here are 2 of the additional templates for this example:

C:\Carlson Projects\Data\DemoSuper.tpl  
GRADES:  Right Side Same as Left

Left SURFACE			Right SURFACE		
Distance	Slope	ID	Distance	Slope	ID
10.000	-4.000%	EP	10.000	-4.000%	EP
1.500	0.000%	CB	1.500	0.000%	CB
0.100	0.500	TC	0.100	0.500	TC
0.500	0.000%	BC	0.500	0.000%	BC

Buttons: Add, Edit, Remove, Up, Down, Cut/Fill, Super, Load, Save

C:\Carlson Projects\Data\DemoReverseCrown.tpl  
GRADES:  Right Side Same as Left

Left SURFACE			Right SURFACE		
Distance	Slope	ID	Distance	Slope	ID
8.000	-2.000%	EP	8.000	-2.000%	EP
1.500	0.000%	CB	1.500	0.000%	CB
0.100	0.500	TC	0.100	0.500	TC
0.500	0.000%	BC	0.500	0.000%	BC

Buttons: Add, Edit, Remove, Up, Down, Cut/Fill, Super, Load, Save

Note here that we have added an additional aspect of lane reduction to 8 units for the DemoReverseCrown.tpl template on the left side. Here we are designing a normal transition up to full super, and then exiting full super at 10-unit width for the EP, transitioning to reverse crown at only 8-unit lane width. So that transition would occur from the PT station 219.62 to reverse crown to at 249.62. To stay and finish at 8-unit





lane width for the EP left, we need 1 more final Demo8. TPL, defined as having an 8 unit EP width, left side. This Template Series file is then created in Road, Utilities, option Input-Edit Template Series. Clear anything that is there (erase icon) and then enter as shown:

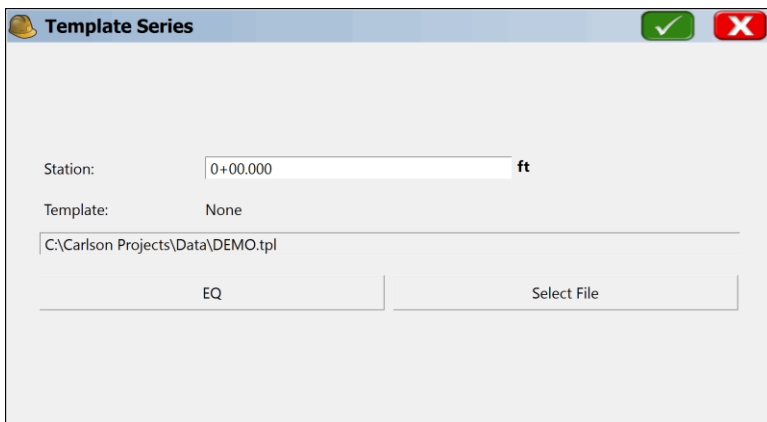
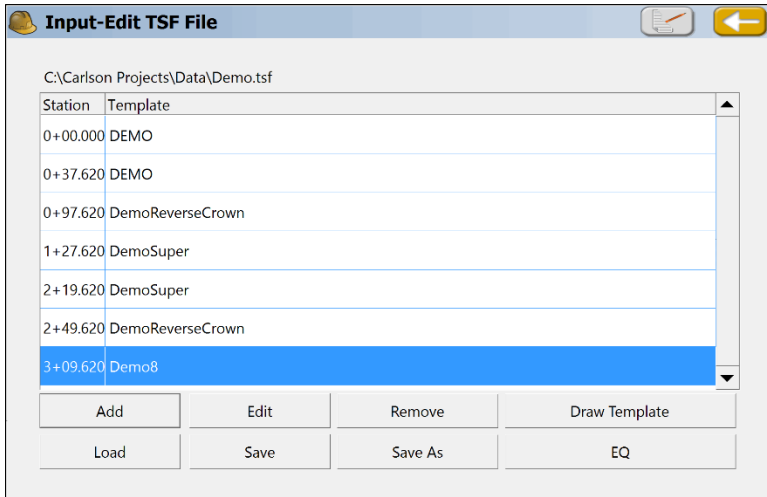

Now when Stake Road is run, station 219.62 shows full super and the transition to a 8 unit lane width occurs from 219.62 to 249.62, holding 8 width on the EP lane through to the end (station 308). Note below left that when selecting the template, you actually load the demo.tsf template series file which includes reference to ALL of the various templates as defined within Input-Edit TSF File. You do not use any optional files in the lower half of the dialog.



**Design Files**

Centerline: C:\Carlson Projects\Data\DEMO.cl  
Centerline: 0+00.000 to 3+08.327

Profile: C:\Program Files (x86)\SurvCEDemo\Data\demo.pro  
Profile: 0+00.000 to 3+08.000

Template: C:\Carlson Projects\Data\Demo.tsf

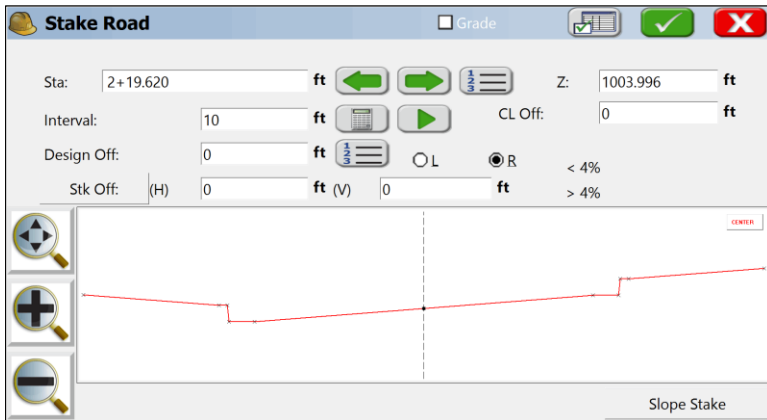

Optional Files

Superelevation	C:\Carlson Projects\Data\Demo.sup
Tpl Transition	None
Tpl Grade Table	None



Compare station 219.62 above (end of full superlevation) to station 127.62 (start of full super) further above as defined by superlevation files. They are similar. Also, note station 234.62. It is halfway through the transition from 10' width to 8' width on the left side (EP=9 Design Offset), and also transitioning from full super (4%) to reverse crown (2%). At station 308, the road superlevation has not fully transitioned back to 2% (at station 309.62). Wherever you pick the middle right of the display shows the cross slope left and cross slope right of your picked point. So the cross slope on the right side is -1.89% trending downward to -2%. Also, note the shorter dimension (8 units) of the EP lane left of centerline.



The variations in the road shown below can be seen in "drive through" mode by entering the starting station, picking an offset to follow (such as Center) and clicking the Green Arrow  opposite the word Interval. This drives through the site at the selected interval, and you can watch grades rise and fall, expand and contract. The Red Box  stops the process.

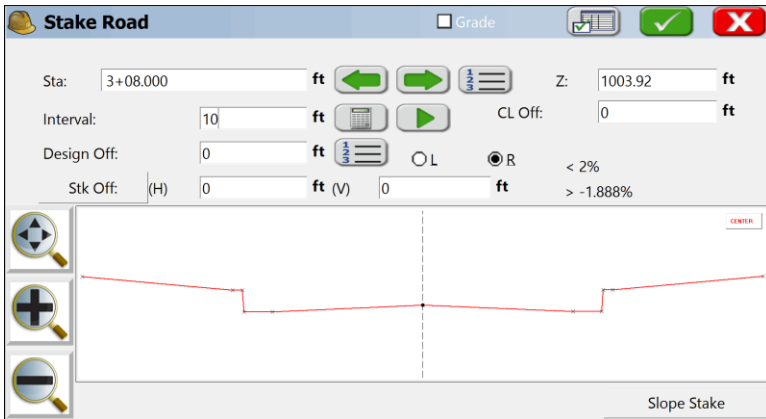
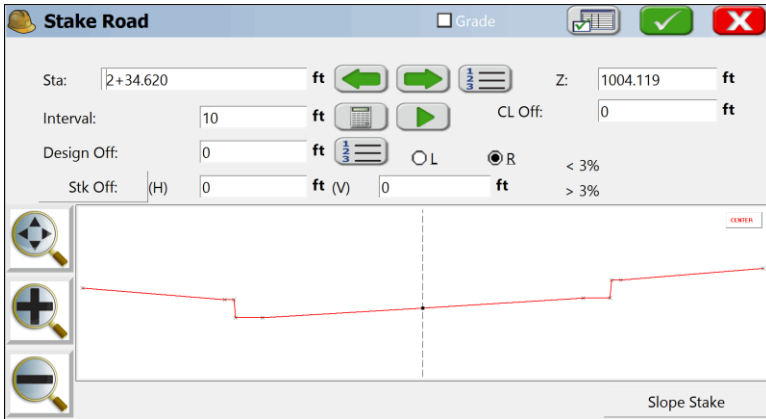

Clicking OK on station 234.62 above would lead to the following stakeout screen, as seen in Plan View (default) and Section View (click Plan/Section in upper left of screen to switch between views). The button shows current view status.

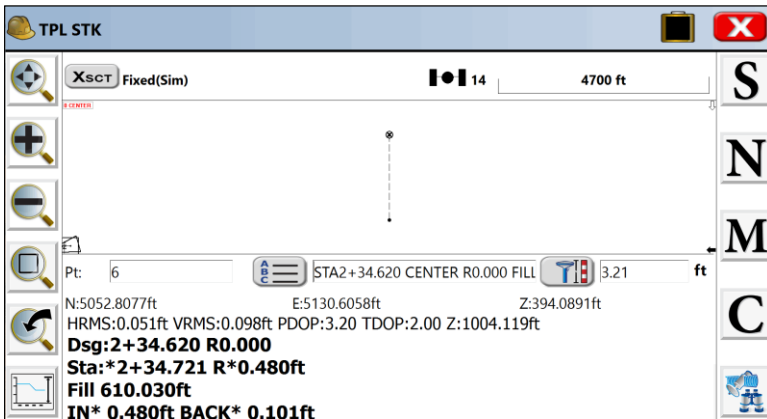
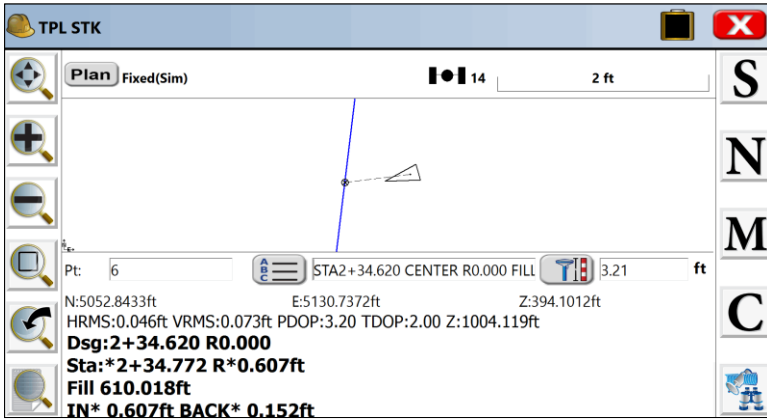

In section view, if the vertical exaggeration is too large, tap the lower left icon (circled in red) and reduce the vertical exaggeration to 1 or 2, real-time, while in the process of staking the point. If the position is within tolerance settings under Equip menu for stakeout, the larger 'bullseye' will appear. Note also that using C for Configuration, you can go to the View tab and click on "Use CL for reference object". This means that whenever a horizontal alignment is involved, your instructions will be in the form of forward and back on the alignment, in and out from centerline.



**Design File Example--Divided Highway:** Divided highways with central ditches (sometimes called "depressed medians") can be defined as templates, starting from the center (ditch or low point) and entering each slope out to the cut and fill. In the example below, there is both an inside shoulder (4%) and outside shoulder (also 4%). The template is shown both inside the editor and through the command Draw Template.

Left SURFACE			Right SURFACE		
Distance	Slope	ID	Distance	Slope	ID
24.000	6.000%	MED	24.000	6.000%	MED
8.000	4.000%	EP1	8.000	4.000%	EP1
12.000	2.000%	LANE	12.000	2.000%	LANE
12.000	2.000%	EP2	12.000	2.000%	EP2

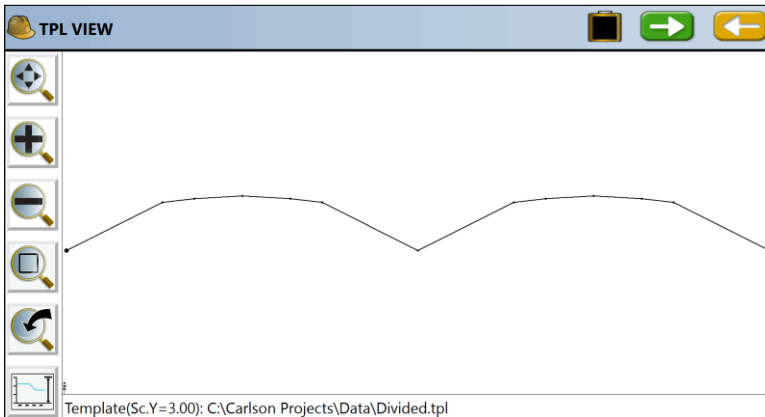

In the Draw Template command, you can Green Arrow to the right and view all template files stored in the current directory of your PC. This is a way to visually "walk through" all your template files to confirm their appearance.

It is using divided highway style templates where use of the first settings button in Stake Road is so essential. In almost all cases, the ditch line is not the defined "grade point" of the road. The vertical alignment or profile is typically applied to the inside edge-of-pavement, in this case "EP1". This is accomplished by clicking Settings in the Design Files dialog (highlighted):



**Design Files** [Icons: Print, Checkmark, Close]

Centerline: C:\Carlson Projects\Data\DEMO.cl  
Centerline: 0+00.000 to 3+08.327

Profile: C:\Program Files (x86)\SurvCEDemo\Data\demo.pro  
Profile: 0+00.000 to 3+08.000

Template: C:\Carlson Projects\Data\Divided.tpl

Optional Files

Superelevation	None
Tpl Transition	None
Tpl Grade Table	None

Load Rooding Files      Save Rooding Files

**Settings** [On] [Off] [Checkmark] [Back]

Apply Profile at

Left       Right

Fix Offset      ft

Template ID

Reference Alignment

Vert Off of Profile: 0 ft

- CENTER
- CENTER
- MED
- EP1
- LANE
- EP2
- SHD
- EP3

Then, if a template ID is the grade point, you can choose it from a dropdown list. The profile grade can also be applied to a fixed offset (26 feet right for example) or to an entirely different reference alignment (selected as a .cl file). You can specify a vertical offset for the profile as well. So, if you defined your template as the subgrade slopes rather than surface slopes, your goal being to stake subgrade, you would need to reference the subgrade to the true profile of the road by entering a vertical offset. The use of the profile offset and reference itself can be turned on and off at the top of the screen. Until the Profile Setting is turned off, Stake Road always passes through the dialog above right to be sure you intend to use the current settings.



So, with this setting, and recognizing that the profile grade at station 100 is 1001.00, staking of the centerline ditch or depressed median will result in a recalculated center profile grade of 996.68.

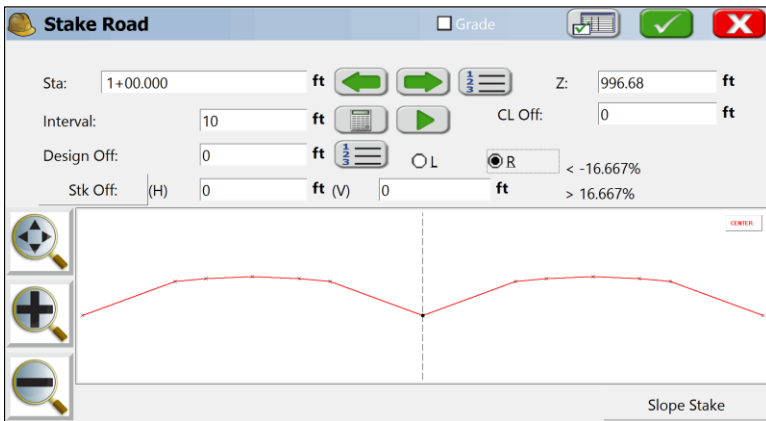
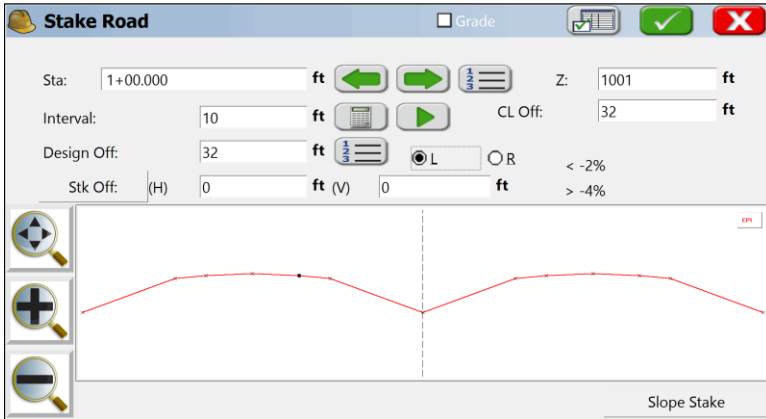



Divided Highways also offer challenges regarding superelevation. When in superelevation, only certain lanes respond and slopes such as shoulders and the inside ditch slopes remain constant. Within Input-Edit Template File, click on "Super" to set the controls for where superelevation applies:

The screenshot shows the "Super Elevation Settings" dialog box. It has a title bar with a yellow icon, a green checkmark, and a red X. The "Divided Road" checkbox is checked. There are two sections for transition points: "Transition from Normal to Super(Inside Edge)" and "Transition from Normal to Super(Outside Edge)". Each section has "High Side PP:" and "Low Side PP:" fields, both containing "EP1" and "EP2" respectively. At the bottom, "Max Percent Slope Difference:" is set to "7%" and "Low Side Grades to Match Greater SUP Slope:" is set to "1".

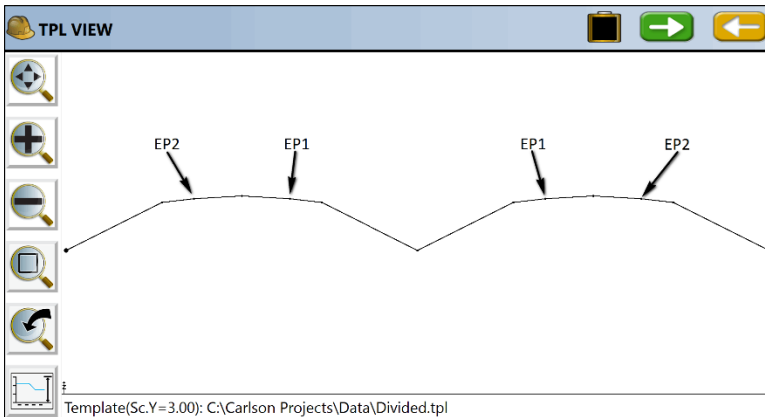

With the above settings, even with superelevation applying to the 2-lane driving surfaces only, the outside and inside shoulders will change if the Maximum Algebraic Difference of the slope percentages are more than 7%. So, if the normal shoulder is 4%, and the road is in 4% super, then the uphill shoulder of the road at 4% downhill would result in an 8% algebraic difference. Thus, a 3% outside shoulder slope will be forced. This prevents "bottoming out" of vehicles as they drive outside the passing lane towards the shoulder in high-side superelevation. Here is an example of this applied in 4% superelevation. Note how the maximum 7% algebraic difference, forcing the shoulder to 3% from normal 4%, applies to both the inside and outside high side lanes.





**Stake Road**  Grade

Sta: 2+00.000 ft Z: 1003.75 ft

Interval: 10 ft CL Off: 32 ft

Design Off: 32 ft  L  R < 4%

Stk Off: (H) 0 ft (V) 0 ft > 4%

Slope Stake

**Stake Road**  Grade

Sta: 2+00.000 ft Z: 1004.71 ft

Interval: 10 ft CL Off: 56 ft

Design Off: 56 ft  L  R < 4%

Stk Off: (H) 0 ft (V) 0 ft > -3%

Slope Stake



Shown below is a staking of a Horizontal Offset of 4 from the outside right shoulder, extending the shoulder slope to the right on station 210.

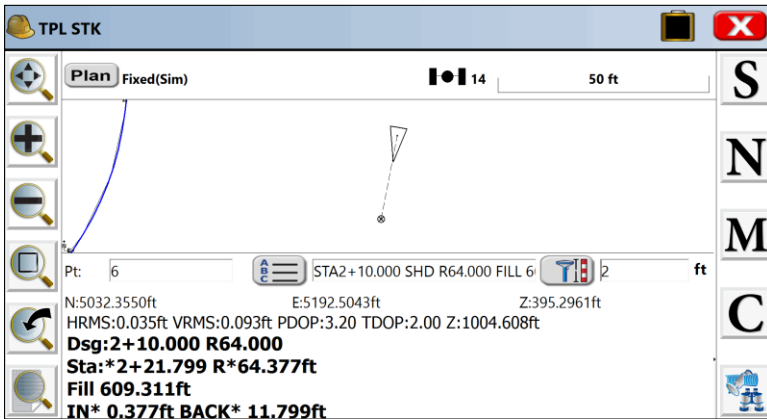
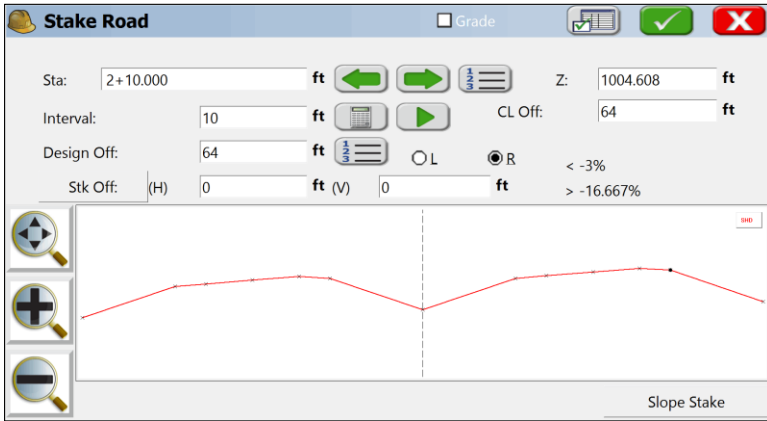



### Design File Example with Reduced or Expanded Lane Dimensions using

**"Template Transition" (.tpl) File:** Let's say that starting at station 200, the road shrinks from a width of 10 units on the left side to 6 at station 300. This can be accomplished, per above, by Template Series Files. But there is a file known as a Template Transition File and it is one of the only files requiring Carlson Civil, the Carlson office solution for road design, to make in advance. This is done using the command "Template Transition" under the Roads pulldown of Carlson Civil. The stations need to be entered in increasing order for start transition, Full Template (complete transition), and end Full Template and resume normal template. If there is no resumption of normal template, enter stations beyond the job range.

**Design Files**

Centerline: C:\Carlson Projects\Data\DEMO.cl  
Centerline: 0+00.000 to 3+08.327

Profile: C:\Program Files (x86)\SurvCEDemo\Data\demo.pro  
Profile: 0+00.000 to 3+08.000

Template: C:\Carlson Projects\Data\Divided.tpl

Optional Files

Superelevation	None
Tpl Transition	C:\Carlson Projects\Data\TEMP.tpl
Tpl Grade Table	None

Load Rooding Files      Save Rooding Files

**Stake Road**  Grade

Sta: 3+00.000 ft    Z: 1003.88 ft

Interval: 5 ft    CL Off: 6 ft

Design Off: 6 ft     L     R    < 2%

Stk Off: (H) 0 ft (V) 0 ft    > 2%

Slope Stake

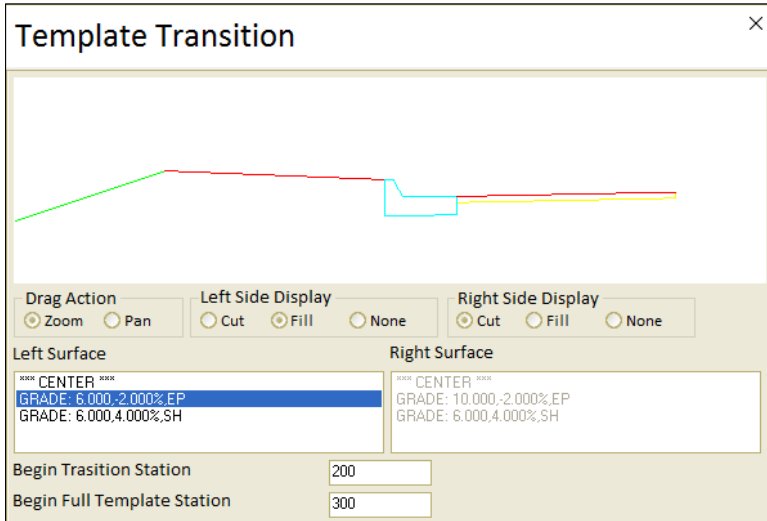

Note that at station 300, the full EP position is at Design Offset 6, based on the DEMO template transition file (DEMO.TPT). At station 250, the EP lane would be 8 units wide, halfway between normal 10 at station 200 and the reduced width of 6 at station 300. The Template Transition File is a relatively crude method compared to others and can be considered a "legacy" feature reading Carlson Civil ".tpt" files. The expansion or contraction of road lanes, with the greater flexibility of both maintaining AND altering cross slopes, can be accomplished with Template Series Files (described in Superelevation example above) and with Template Grade Table Files, described next.



**Design File Example with Template Grade Table File:** The same example using Template Series File, where the Demo.tpl road is transitioned through 4% superelevation and a lane width change, left side from 10 to 8, can be accomplished identically using a Template Grade Table. The Template Grade Table takes a single template and associates specific lane width and slopes with any specified template ID point, left or right. This method has the ultimate flexibility for controlling road designs. Although described in the section on Road, Utilities, here is the above example accomplished using the Template Grade Table.

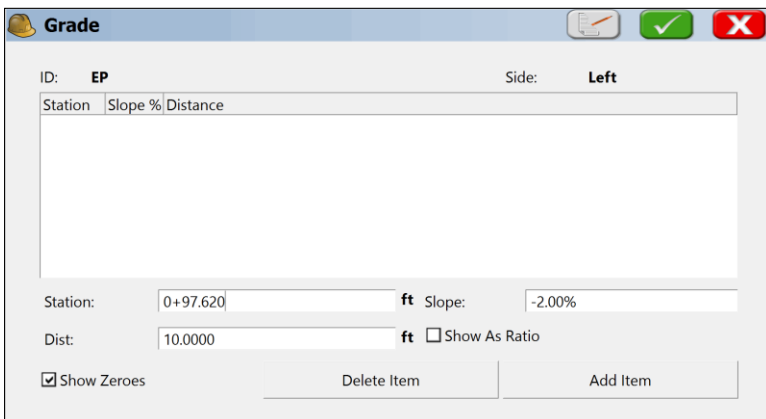
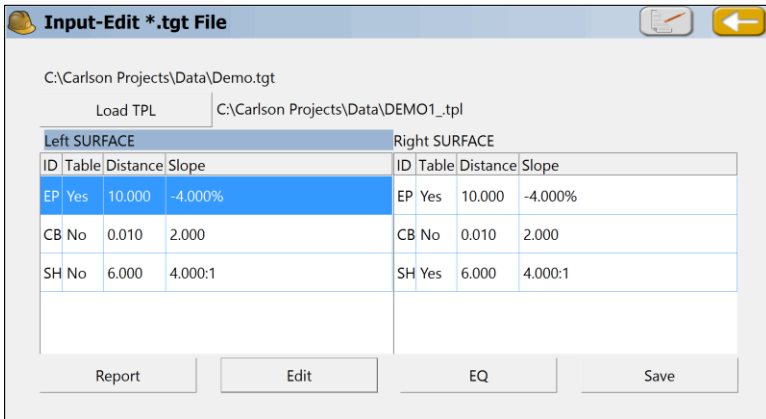

You start by selecting the grade that will change. In this case, both the EP Left and the EP Right grades will be impacted by superelevation and lane width changes. So you can start by selecting EP Left. You next enter the station where the continuous transition from normal EP Left grade/slope to a different EP Left grade/slope occurs. The last station where 10 width at -2% occurs is reverse crown (2% all the way across) or 97.62. Enter that data and then click "Add Item". The next station controlling the transitional slopes on the left side would be full superelevation (-4%) at station 127.62.



Continue entering the data as shown below left. The left EP lane holds -2% slope and 8 width through the end starting at 249.62, so no final station needs to be entered. For the left side, only 4 stations, as shown, control all the EP transitions.

**Grade** [Print] [Check] [Close]

ID: **EP** Side: **Left**

Station	Slope %	Distance
0+97.620	-2.000	10.0000
1+27.620	-4.000	8.0000
2+19.620	-4.000	10.0000
2+49.620	-2.000	8.0000

Station:  ft Slope:

Dist:  ft  Show As Ratio

Show Zeroes

**Grade** [Print] [Check] [Close]

ID: **EP** Side: **Right**

Station	Slope %	Distance
0+37.620	-2.000	10.0000
1+27.620	4.000	10.0000
2+19.620	4.000	10.0000
3+09.620	-2.000	10.0000



Station:  ft Slope:

Dist:  ft  Show As Ratio

Show Zeroes

Turning attention to the right side, or "high side" in the superelevation caused by a curve to the left, the transition out of normal crown begins at station 37.62. So this must be entered as the last "normal" width/slope station for the EP Right. Then the next controlling station is all the way to the full super at 127.62, since the rate of transition is consistent in this example (2% over each 30 length of road). The right side would have slope 0% at 67.62, +2% at 97.62 and +4% at 127.62 as shown, so only the latter, controlling station data needs to be entered. Complete the entire data for the right side EP as shown below:



**Grade**   



ID: **EP** Side: **Right**

Station	Slope %	Distance
0+37.620	-2.000	10.0000
1+27.620	4.000	10.0000
2+19.620	4.000	10.0000
3+09.620	-2.000	10.0000

Station:  ft Slope:

Dist:  ft  Show As Ratio

Show Zeroes

**Input-Edit \*.tgt File**  

C:\Carlson Projects\Data\Demo.tgt

C:\Carlson Projects\Data\DEMO1.tpl

Left SURFACE				Right SURFACE			
ID	Table	Distance	Slope	ID	Table	Distance	Slope
EP	No	10.000	-4.000%	EP	Yes	10.000	-4.000%
SH	No	6.000	4.000:1	SH	Yes	6.000	4.000:1

When both EP Left and Right sides are edited, they are marked "Yes" in the Template Grade Table dialog, indicating those template IDs have distinct grade tables. (If, for example, a shoulder dimension was expanded on the right side, it could have its own Grade Table). Note how different the left side EP data is from the right side EP data-- the pivot points for grade changes are different in each case, only identical at the shared full superelevation stations. If the station for the left EP lane width change was different than the precise "reverse crown" station, then a new and separate station would be entered controlling only that lane transition point. Template Grade Tables are ideal for transitioning road rehabilitation projects to existing, undisturbed, as-built road template dimensions and slopes.

Clicking Report in the Template Grade Table routine leads to the presentation at lower right. Now to apply the Demo.tgt Template Grade Table File, add it as an "optional" file in the Stake Road, Design File option. Click OK to proceed.



TPL Grade Table Report		
1+27.620	-4.000%	8.000
2+19.620	-4.000%	10.000
2+49.620	-2.000%	8.000
Grade: EP Right		
Station	Slope%	Distance
0+37.620	-2.000%	10.000
1+27.620	4.000%	10.000
2+19.620	4.000%	10.000
3+09.620	-2.000%	10.000
Grade: SH Right		
Station	Slope%	Distance
1+27.620	4.000%	10.000
2+19.620	4.000%	10.000

Design Files	
Centerline	C:\Carlson Projects\Data\DEMO.cl
Centerline: 0+00.000 to 3+08.327	
Profile	C:\Carlson Projects\Data\DEMO.pro
Profile: 0+00.000 to 3+08.000	
Template	C:\Carlson Projects\Data\DEMO1_.tpl
Optional Files	
Superelevation	None
Tpl Transition	None
Tpl Grade Table	C:\Carlson Projects\Data\Demo.tgt
Load Rooding Files	Save Rooding Files

Note 8 dimension of EP lane width on station 280 when EP Left is clicked on the screen, and when the Center point is clicked, the right lane appears in slope transition downward from full super (at 0.1% uphill grade, nearly flat). Experimenting with different stations or clicking the green arrow "drive through" button both help verify the accuracy of the Template Grade Table entries. It is important to point out that the Design File method allows templates to be adjusted 3 distinct ways: (1) acted on by superelevation (.sup) and lane transition (.tpl) files, (2) transitioned from one template to another with the Template Series File and (3) modified by a Template Grade Table file. The "Cut from Alignments" and Road Model options discussed below may be considered a fourth way, where template ID points can be assigned their own centerlines and profiles, as read from the drawing, directly assigned, or loaded from a LandXML file (Road Model method).





**Stake Road**  Grade

Sta: 2+80.000 ft Z: 1003.99 ft

Interval: 10 ft CL Off: 8 ft

Design Off: 8 ft  L  R < 0%  
> 2%

Stk Off: (H) 0 ft (V) 0 ft

Slope Stake

**Stake Road**  Grade

Sta: 2+80.000 ft Z: 1004.15 ft

Interval: 10 ft CL Off: 0 ft

Design Off: 0 ft  L  R < 2%  
> -0.1%

Stk Off: (H) 0 ft (V) 0 ft

Slope Stake



## Section File Method

**Section File Example with Multiple Sections and Longitudinal Pipes:** For complicated roads, the cross-section data, provided at intervals and key stations on the alignment, is very often the "official" design data for purposes of construction. Staking out cross - sections according to the plans, therefore, is standard operating procedure in road construction stakeout. The challenge is often obtaining the cross-section data. Sometimes it is available in LandXML format, which SurvPC can read within Road, Utilities. It may also be available in a Columnar Text format, which SurvPC also reads. As a last resort, cross-section data can be hand entered to form the SurvPC ".sct" file, using the command Input-Edit Section File within Road, Utilities. There is a special format for Longitudinal Pipe Data that can be read automatically by SurvPC. This format, including the header line, is as follows (the "+" in the stationing is optional):

<b>STA</b>	<b>Offset</b>	<b>FL Elev.</b>	<b>Link – ID</b>	<b>Link – Library Item</b>	<b>Type</b>
13+00.00	52.13	22.32	NP-26	18” RCP	T
14+00.00	-47.61	22.08	NP-1	18” CMP	T
14+00.00	49.63	22.02	NP-26	18” RCP	T
15+00.00	-39.58	21.78	NP-1	18” CMP	T

The 18" RCP (reinforced concrete pipe), for example, is found at station 13+00 at offset 52.13, flow line elevation (invert) of 22.32, Type 18" RCP and again at station 14+00, offset 49.63, flow line elevation of 22.02. The "Link-ID" column tracks the pipe ID from station to station, and the Link-Library Item is used to confirm the linked pipe and for purposes of display. The final column is used as a pipe designation and should be included. Longitudinal pipe data can also be entered directly within Input-Edit Section File as shown below. Note that the pipe size and name come first in the description. When importing from an ASCII File, the Link - Library Item is found and sorted such that it goes first in the description field.



Multiple cross - section files can be loaded by the option "Add Section" in the opening dialog of the Section option within Stake Road, Section File, Section Tab. You can Delete Sections from the list, and you can assign a Layer to the Sections.

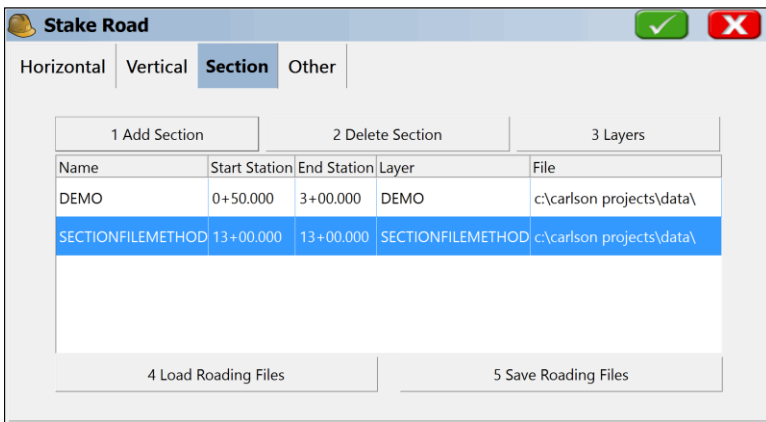
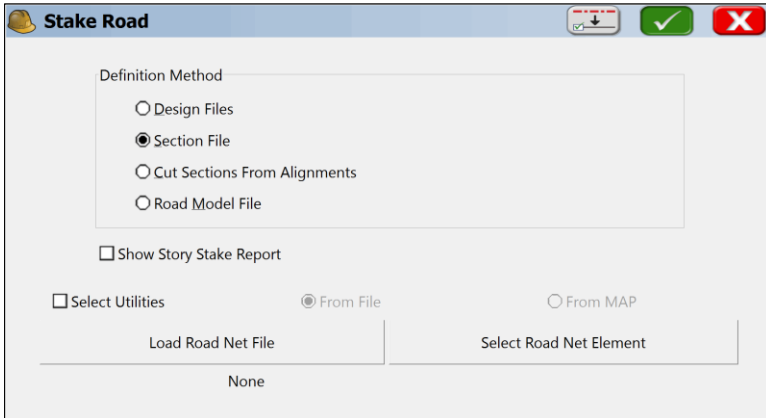

The Horizontal and Vertical Tabs are similar to those in Stake Line/Arc. The Horizontal Alignment (whether loaded as a ".cl" file or picked from the screen) MUST be selected. The +Vertical Alignment is optional, but for roads with high and low points, the vertical alignment is necessary to interpolate sections correctly when these high and low points or grade changes on the road profile, fall within the station interval. For example, if cross - sections were available at a 50-foot interval, but there was a high point at station 17+75, the vertical alignment would be critical for accurate interpolation of station 17+75. You have the option to apply the vertical alignment or work strictly with the cross-sections.

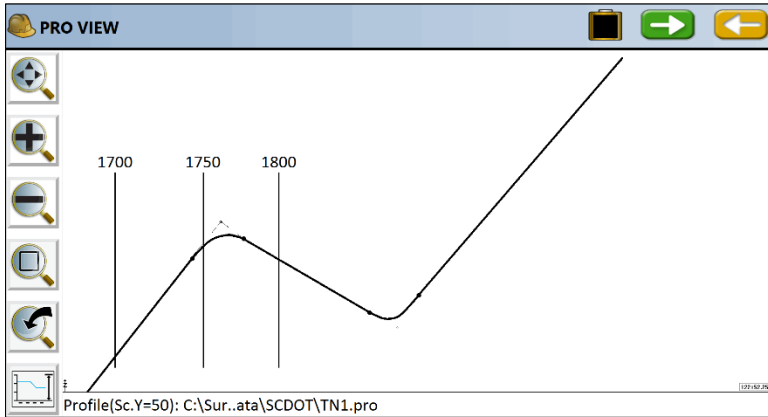

Stake Road

Horizontal **Vertical** Section Other

1 Profile File

2 Select Polyline 5 Preview 6 Edit

3 Define Point List 7 Save As

Profile: C:\Sur..mo\Data\SCDOT\SC46RFP.pro

Start Station: 1062.320 ft

Ending Station: 6254.154 ft

Apply Vertical Alignment

When you click OK (green check), you proceed to the Section Selection screen. Here you can select in the lower portion of the dialog which surface or sections to stake out. All break points on each selected surface appear. If a pipe is selected, its data appears in the upper right. If the cross - sections did not contain descriptions, then only the design offset appears in the dialog, along with the slopes left and right of the selected point. You can pick the points to stakeout graphically on the screen.



**Stake Road**  Grade

Sta: 1300.000 ft    Z: 22.32 ft

Interval: 10 ft   CL Off: 18.5 ft

Design Off: 18.5 ft   L  R < -2.034%

Stk Off: (H) 0 ft (V) 0 ft > -2.069%

SC467XSPIPES  
SC46R\_SX\_LIST\_TOP  
SC46R\_SX\_LIST\_SUB  
Surface: SC46R\_SX\_LIST\_SUB Slope Stake

**Stake Road**  Grade

Sta: 1300.000 ft    Z: 22.32 ft

Interval: 10 ft   CL Off: 52.13 ft

Design Off: 52.13 ft   L  R < -2.034%

Stk Off: (H) 0 ft (V) 0 ft > -2.069%

Surface: SC46R\_SX\_LIST\_SUB Slope Stake

The selected or highlighted cross - section surface always appears red and bold for purposes of stakeout. The Settings button at the top of the screen leads to the standard Road Stakeout settings controls, also found in Job Settings, Stake tab.



**Section File with Reference Point in Stake Road (For 2 Cut/Fill Results):** The staking of pipes offers a convenient point to introduce the topic of the Road Stake Reference Point. If you click the "From List" button opposite the Design Offset within Stake Road, you are taken to a special list, that offers the ability not just to select the offset and elevation to stake, but to pick a section surface and a reference point on that section to use for stakeout. In this case, we selected the 2nd from left offset point, top of the fill slope, and then clicked "Set REF". This expands the information on the screen to include the reference point offset, to show that point as a black symbol with solid circle inside, along with the target point, in this case the 18" CMP pipe at station 1400.

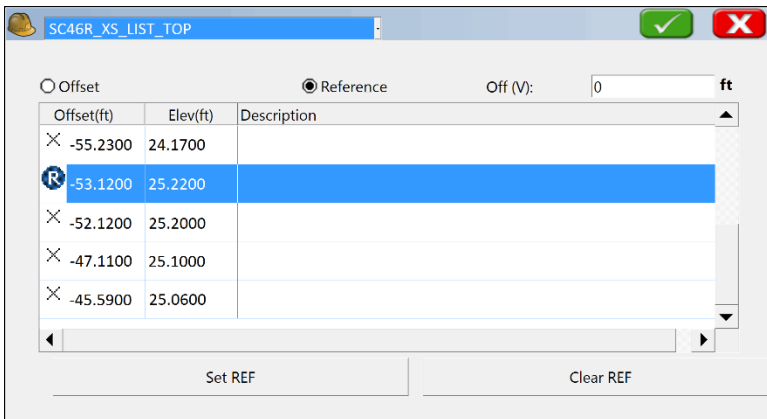
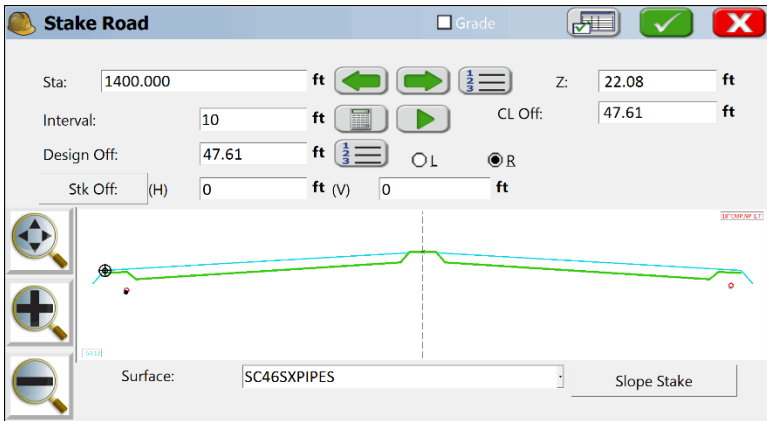



Now when you click OK (green check) to proceed, additional information is presented on the screen during the stakeout process.

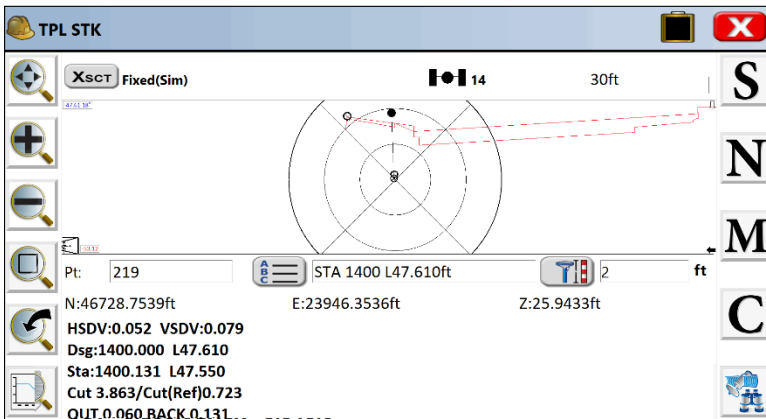
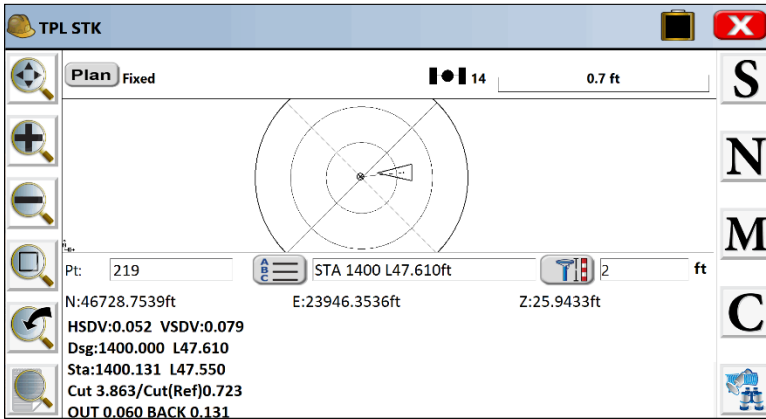

With reference points, the in-out and forward-back guidance is to the target point, but the cut and fill information is provided to both the target AND the reference point. Since the pipe target point is well below the top of bank reference point, cut to the reference in this example is just 0.7 approximately while cut to the pipe is 3.9 approximately. A single stake marking the pipe could show the cut to the shoulder as well. If the reference were reversed, you could stake the shoulder point and also reference the cut to the pipe as additional information to mark on the stake. Options to show North/East or Station/Offset are provided in the Stakeout Report.



**Stakeout Report**  Ref CL

Show North/East       Show Station/Offset

	Northing(ft)	Easting(ft)	Elevation(ft)
Staked:	46728.842	23946.387	25.958
Design:	46728.883	23946.416	22.080

Move:    North:0.041ft    East:0.030ft    C 38.78ft/C(Ref)0.738ft

Voff 1:  ft    Elev:  ft

Voff 2:  ft    Elev:  ft

HRMS:0.009ft      VRMS:0.005ft      PDOP:3.200

Store Point      Point ID:

Set GIS     

**Stakeout Report**  Ref CL

Show North/East       Show Station/Offset

	Station	Offset	Elevation(ft)
Staked:	1400.042	L42.581	25.958
Design:	1400.000	L47.610	22.080

Move:    BACK:0.042ft    OUT:0.030ft    C 38.78ft/C(Ref)0.738ft

Voff 1:  ft    Elev:  ft

Voff 2:  ft    Elev:  ft

HRMS:0.009ft      VRMS:0.005ft      PDOP:3.200

Store Point      Point ID:

Set GIS     

Be sure to clear the Reference Point so it does not stay active.





**Section File with Story Stake for ALL Cut/Fills to all Break Points:** When staking out cross - sections, it is beneficial to turn on "Show Story Stake Report". Whereas the Reference Point method outlined above provides 2 cut/fill values, the Story Stake provides All Cut/Fill values and is easy to use. The one advantage of the Reference Point method is that the reference can be on a different cross - section surface. Regarding the Story Stake, set it on in the opening screen. Then choose a point on a surface with many break points to stake out.

When the point is staked, the initial report screen shows the individual cut fill to the selected point:

Show North/East     Show Station/Offset

	Station	Offset	Elevation
Staked:	1399.996	L53.122	25.954
Design:	1400.000	L53.120	25.220

Move: FWD: 0.004 ft  
IN: 0.002 ft      Cut 0.734

Voff 1:  Elev:

Voff 2:  Elev:

HRMS:0.009    VRMS:0.005    PDOP:3.200

Store Point    Point ID: 219

Point Description: TA 1400.000 L53.120 CUT0.734

When you click OK with Story Stake turned on, you obtain both Progressive and Total numbers for the entire list of offsets for the cross - section up to Center (entire left side in this case). And if you turned off "Report to Center", you would get a cut/fill report for all offsets on the entire cross - sections, from the single staked point.

<input checked="" type="radio"/> Progressive <input type="radio"/> Total	
<input checked="" type="checkbox"/> Show Report Up to CENTER	
Offset PT	Sta:    Offset:                      Elevation:
1400.000	L53.122                      25.954
	HDIST    VDIST    SLOPE
55.23 to 53.12	2.11    1.05    FILL 49.8% 2.0:1
55.23 to 52.12	1.00    0.02    CUT 2.0% 50.1:1
55.23 to 47.11	5.01    0.10    CUT 2.0% 50.1:1
55.23 to 45.09	2.02    0.04    CUT 2.0% 50.5:1
55.23 to 44.59	0.50    0.00    FILL 0.0% 999.9:1
55.23 to 44.51	0.08    0.50    CUT 625.0% 0.2:1

<input checked="" type="radio"/> Progressive <input type="radio"/> Total	
<input checked="" type="checkbox"/> Show Report Up to CENTER	
Offset PT	Sta:    Offset:                      Elevation:
1400.000	L53.122                      25.954
	HDIST    VDIST    SLOPE
OFFSET to 55.23	2.11    1.78    CUT 84.6% 1.0:1
OFFSET to 53.12	0.00    0.73    CUT 999.9% 0.2:1
OFFSET to 52.12	1.00    0.75    CUT 75.2% 1.0:1
OFFSET to 47.11	6.01    0.85    CUT 14.2% 7.1:1
OFFSET to 45.09	8.03    0.89    CUT 11.1% 9.1:1
OFFSET to 44.59	8.53    0.89    CUT 10.5% 9.1:1



Note that the Progressive Report shows the relative vertical distances between offset points and does not utilize the field-staked elevation in the vertical calculation. But on the Total Report, the vertical difference is from the staked position to each of the offsets. Study the 4th column for the direction of the vertical difference as cut or fill.

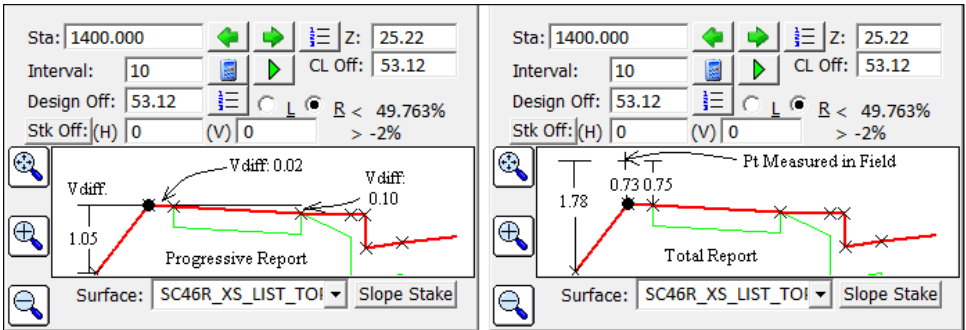

This report can also be saved to a user-formatted cutsheet file. Later in the Stake Road documentation, formatting of Story Stake cutsheets are discussed.

**Section File Method using RNF Files from Carlson Civil, Road Network:** Carlson Civil will output complete stakeout files in the form of "RNF" files as both Design Files and Section Files to stake all portions of road networks, including intersections and cul-de-sacs. Shown below is a road, viewed in 3D, designed in the Carlson Civil Road Networks command, including the option within Settings, Output Options tab, that produces the named ".rnf" file (Road Network File).

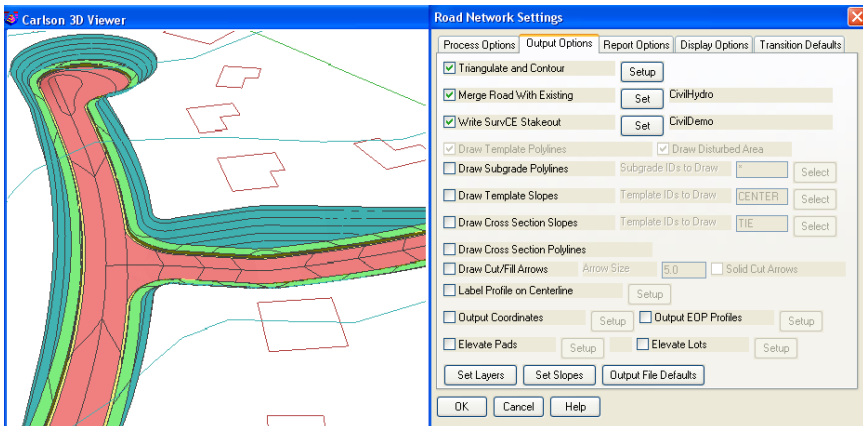



It is recommended that the RNF files be staked out using the Sections options within Stake Road--since all surfaces can be viewed and selected (e.g. surface of road, shoulder and cut/fill slopes, plus all subgrades). The Section Method offers the flexibility to select any desired Road Net Element for stakeout, as output in the form of the RNF file. To use the command, select the RNF file at the lower left of the opening dialog, then select the Road Net Element to stake, either graphically as shown or from the pull-down list. In the above road example, there are 6 elements, named according to the centerline files involved: (1) First Part Main Road (2) Second Part Main Road after Intersection, (3) Side Road, (4) First Curb Return Main Road to Side Road, (5) Second Curb Return Side Road back to Main Road and (6) the Cul-de-Sac.

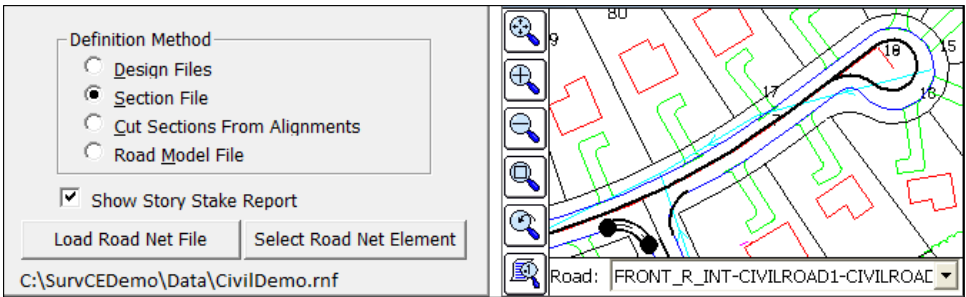

If is our goal to stake the back of curb on the first "Curb Return" as shown, then select it and choose the top surface and pick the back of curb point. If you pick "From List" for the Stations, you can review the entire station range for this small curb return, which in this case is 45.96 as shown below right. So staking Station 24 on this special segment would be approximately halfway around the curb return. Note the "centerline" used for this is the edge-of-pavement or left-most point on the curb, so that the back of curb appears as CL Offset 1.5 (curb is 1.5 units wide).

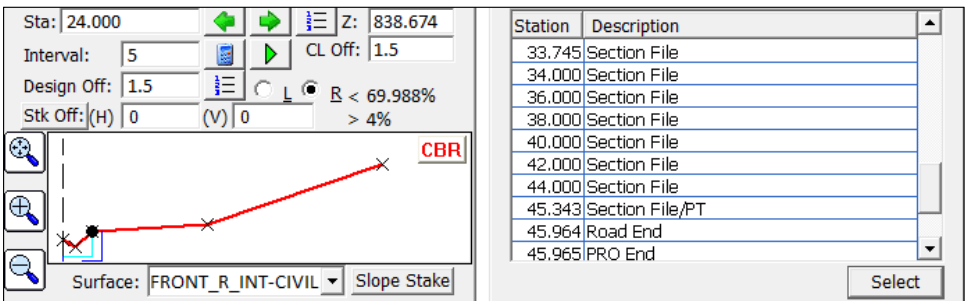



Note how any surface or subgrade point can be selected and staked out, at any distance along the special "centerline" for this curb return segment. The next procedure is to click OK to continue, to enter the stakeout screen, shown below in both plan view and cross - section view.

Plan View (50 ft)	Cross-Section View (7 ft)
Pt: 1011 Desc: STA 24.000 HT: 6	Pt: 1011 Desc: STA 24.000 HT: 6
N:3268.6277 E:4536.1289 Z:839.9896	N:3271.0775 E:4537.0836 Z:840.0017
HSDV:0.051 VSDV:0.087 Z:838.674	HSDV:0.044 VSDV:0.094 Z:838.674
Dsg:24.000 R1.500	Dsg:24.000 R1.500
Sta:24.147 R6.670	Sta:23.932 R4.047
Cut 1.316	Cut 1.328
IN 5.170 BACK 0.147	IN 2.547 FWD 0.068

The process can be repeated for the cul-de-sac. Here we will stake out both the stone subgrade outside point and then we will slope stake the catch at a station approximately 1/4 of the distance around the cul-de-sac:

Plan View	Cross-Section View
Road: CDS E-CIVILROAD1	Surface: SUB2_CDS_E-CIVILR
Sta: 50.000	CL Off: 14
Interval: 2	Stk Off: (H) 0 (V) 0
Design Off: 14	R < 4%
	> 0.1%

The cul-de-sac "centerline" is the outside edge-of-pavement facing the curb, and by clicking "From List" opposite Station, is seen to be just over 200 in total length in the screen below left. Staking out station 50 would be approximately 1/4 of the distance around the cul-de-sac.



Station	Description
198.000	Section File
200.000	Section File
202.000	Section File
204.000	Section File
206.000	Section File
208.000	Section File
210.000	Section File
210.718	Road End
210.719	PRO End

Plan Fixed 14 110 ft

Pt: 1011 Desc: STA 50.000 HT: 6  
N:3381.4995 E:4744.1779 Z:839.9935  
HSDV:0.049 VSDV:0.070 Z:838.339  
Dsg:50.000 R14.000  
Sta:50.720 R28.965  
Cut 1.655  
IN 14.965 BACK 0.720

Select

The "catch" point at the top of cut can be staked out for station 50 by selecting the top surface outside shoulder point and then clicking the Slope Stake button in the lower right of the screen:

Sta: 50.000 Z: 839.756  
Interval: 10 CL Off: 19.5  
Design Off: 19.5 R < 4%  
Stk Off: (H) 0 (V) 0 > 24.998%

Surface: CDS\_E-CIVILROAD1 Slope Stake

Slope: Define Slope by Next Section Poi R

CUT: 4.00:1  
FILL: 3.00:1  
 Ratio  Mirror CP

Pivot Point - Edge of Road  Elev From Files  
Pivot Pt (Z/O/D): 839.756m R19.5 User(SH)  
Design Pt (Z/O): 839.756 R19.5  
Stake Off (V/H): 0 L0  
Ref Off (V/Z): 0 N/A

Slope Staking takes you to a "parameter" dialog where you set the Pivot Point type (here it is "User Selection") and how the next slope is defined. By selecting "Define Slope by Next Section Point", the program detects that point is in cut, so calculates the cut upslope at 4:1 (matching the >25% at left) and ghosts the value so it cannot be changed. You can also change the selection type to "User Defined" and enter any cut upslope ratio you prefer. Then click the Green Check (OK) to continue:

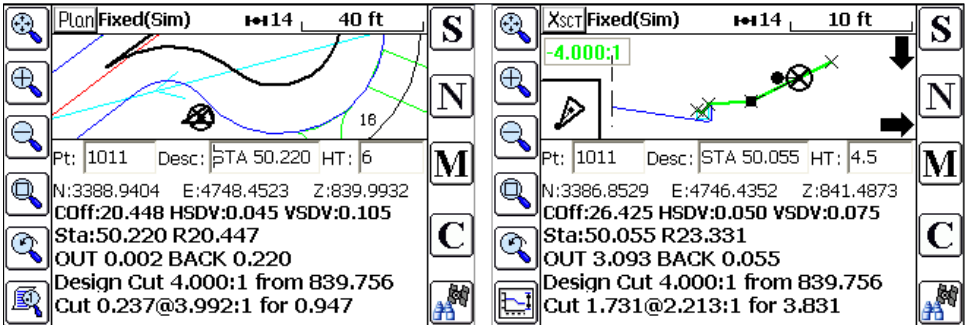

Note that with a rod height of 4.5 in this simulated example above right, the ground catch position is projected at lower than the original estimate further to the right. This is often the case in slope staking--the ground has been altered since the design was conducted and you must react to actual field conditions. It should also be noted that the Slope Stake command "models" the existing ground real-time as you move, making the best estimate it can of the projected or interpolated catch point position. Since it works real time with GPS without taking a measurement (as required with a total station), it is best to keep the base of the pole close to the ground. Slope Staking leads to the Slope Reports shown below:

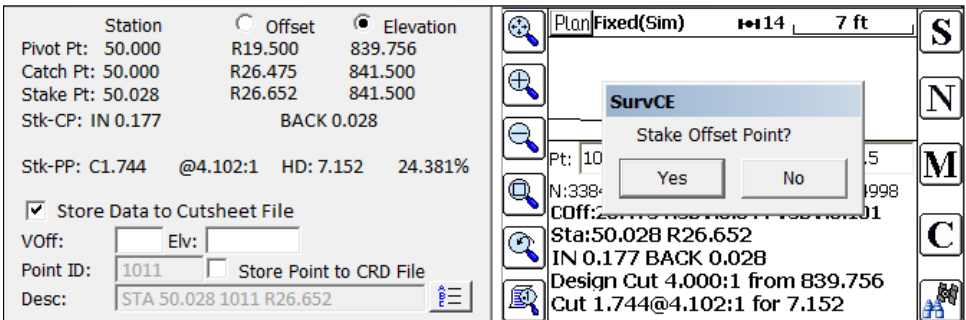

It is recommended whenever doing Slope Staking to stake the first Offset Point, in case the actual catch point stake is knocked out during construction. Typically click Yes to the above prompt, "Stake Offset Point?" Use the "Delta Distance" option.



Station:

Offset:

Offset Type

CL Offset     Delta Distance from Catch Pt

Plan Fixed(Sim) 14 30 ft

Pt: 1011 Desc: STA 49.982 HT: 4.5

N:3383.5117 E:4743.6356 Z:841.5090

HSDV:0.041 VSDV:0.096

Dsg:50.000 R31.475

Sta:49.982 R27.688

OUT 3.787 FWD 0.018

When the offset stake is placed, you can do a second offset. This is sometimes beneficial in extremely small radius curves, such as a cul-de-sac, in order to have 2 stakes to point in the direction of the true catch point. But in most cases, it is unnecessary. The slope stake report is shown below:

Current: Northing 3380.499 Easting 4741.337 Elevation 841.488

Target: Northing 3380.503 Easting 4741.335

Difference: 0.005

Store Point to CRD File

Store Data to Cutsheet File

Point ID:

Description:

Progressive     Total     Combo    OFFSET

Show Report Up to CENTER

Offset PT Sta: 50.002    Offset: R31.477    Elevation: 841.488

	HDIST	VDIST	SLOPE
OFFSET to CATCH	5.00	0.01	FILL 0.2% 423.5
OFFSET to PIVOT	11.98	1.73	CUT 14.5% 6.9:
OFFSET to CBR	17.98	1.97	CUT 11.0% 9.1:
OFFSET to CBR2	18.81	2.56	CUT 13.6% 7.4:
OFFSET to EP	19.48	2.31	CUT 11.8% 8.4:

The "Combo" option shows a "progressive", incremental slope ratio for each segment (last column), combined with a total HDist and VDist measurement to each point. If you have named and defined a Slope Stake file in advance (File, Job Settings, Stake Tab), and clicked it on for storage, then the slope stake information will be stored in the slope stake file as shown below. The file formats of all of these "cutsheet" types are fully user configurable. A configurable Story Stake Report is outlined later in this chapter.



<input type="checkbox"/> Point Stakes    Format    Edit File Select File    C:\SurvCEDemo\Data\AR.txt	<b>Design Sta</b>	<b>Pivot Off</b>	<b>Elev:PP/CP</b>		
<input type="checkbox"/> Alignment Stakes    Format    Edit File Select File    C:\SurvCEDemo\Data\Logging1.txt	50.000	Right 19.500	841.500		
<input checked="" type="checkbox"/> Slope Stakes    Format    Edit File Select File    C:\SurvCEDemo\Data	OFFSET to CATCH	H 5.002	V 0.012		
<input checked="" type="checkbox"/> Grade Stakes    Format    Edit File Select File    C:\Sur...\Data\SubdivSlope.txt	OFFSET to PIVOT	H 11.977	V 1.732		
<input type="checkbox"/> Story Stakes    Format    Edit File Select File    C:\Sur...\Data\mant-STS.txt	OFFSET to CBR	H 17.977	V 1.972		
	OFFSET to CBR2	H 18.810	V 2.555		
	OFFSET to EP	H 19.477	V 2.305		
	Insert	Up	Down	Delete	Special

### Cut from Alignments Method

If a drawing or DXF file is loaded or created in SurvPC using CAD tools in the Map screen or by Field-to-Finish, 3D Polylines and 2D Polyline Contours can be used to extract cross - sections for stakeout. This is the "Cut from Alignments" option. The normal use of this command is to extract sections from a set of 3D Polylines representing pavement, shoulder, and ditch lines. However, it is possible to actually name the alignments by associating section descriptions with selected centerline (.cl) and profile (.pro) files. In normal use, when extracting sections from a drawing of 3D polylines, the layers of the polylines are used as the section point description. If several polylines are encountered with the same layer name, such as Ditch, then in the direction away from centerline, each subsequent common layer is given an appended number incremented by 1, as in Ditch, Ditch1, Ditch2, to create unique section point descriptions.

Consider the drawing of 3D polylines shown below. In close-up, stationing for the main horizontal alignment (centerline) appears, with a starting station computed to be 219+00.

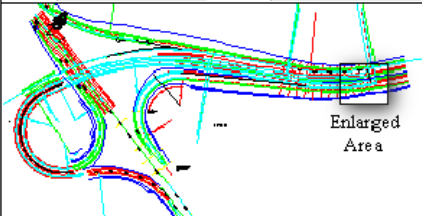
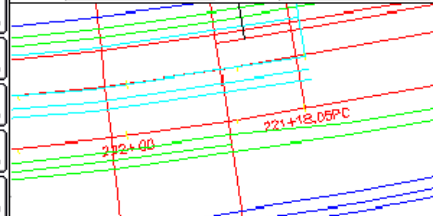
<b>FILE</b> <b>VIEW</b> <b>DRAW</b> <b>COGO</b> <b>TOOLS</b> Cmd:                      Layer: CTR	<b>FILE</b> <b>VIEW</b> <b>DRAW</b> <b>COGO</b> <b>TOOLS</b> Cmd:                      Layer: CTR
	





So, within Stake Road, selected option 3, Cut Sections from Alignments. This leads to the standard alignment selection dialog, with tabs for Horizontal and Vertical Alignments. It is essential to set a Horizontal Alignment. Pick the main centerline (labeled with 221+18.05 PC above).

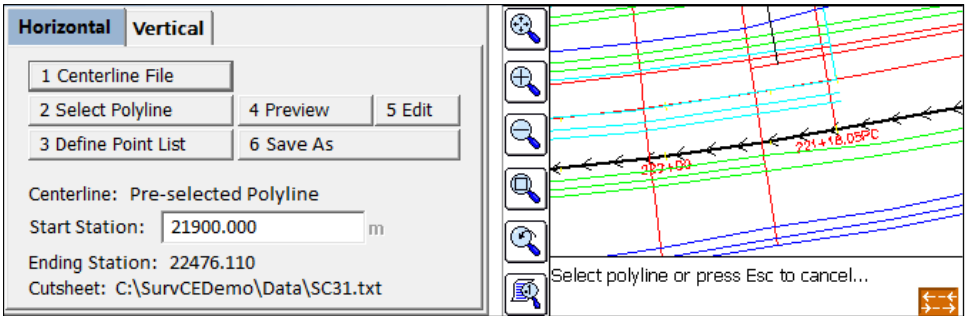

If you are unsure of the direction of the main centerline, pick the orange "Direction Reverse" button. If it was correct to begin with, you will need to reverse again to restore the original direction. It is important to point out that all polylines that will be selected for cross - sectioning need to be drawn in the same direction. So, prior to issuing the Cut from Alignments command, it is a good idea to go to the Map screen and study the polylines involved using the command Draw, Modify, Reverse Polyline. In the above example, all polylines for road, shoulder, ditch and other points need to be drawn and saved right to left, matching the main centerline. When selecting the main centerline, if it is 3D, you will be asked, Overwrite the Vertical Alignment? Answer with Yes. Set the correct Start Station, in this case, 21900 (verify same start station for vertical alignment). Then Ok (green check) to continue.

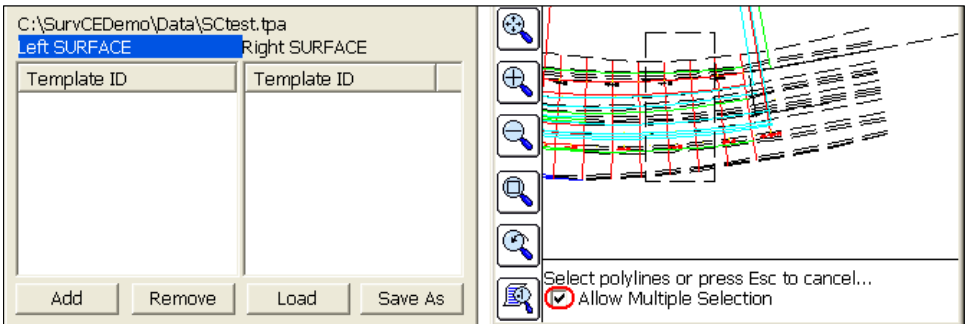

If there is previous data in the 2-column screen, use the Eraser Icon to delete all the data. Then rather than pick one polyline at a time, use the window/crossing selection icon circled in red above left. This leads immediately to a map screen as shown above right. In the lower portion of the dialog, click on "Allow Multiple Selection". Then do any combination of individual picks or window/crossing selections (lower left to upper right or lower right to upper left). A typical selection is shown by the dashed rectangle



above. Click OK to return to the Template Alignment dialog, which now has the data organized in 2 columns:

C:\SurvCEDemo\Data\SCtest.tpa  
Left SURFACE Right SURFACE

Template ID	Template ID
SHLD	ROAD
SHLD1	ROAD1
SHLD2	ROAD2
DITCH	SHLD
DITCH1	SHLD1
DITCH2	DITCH
	SHLD2
	SHLD3

Add Remove Load Save As

Sta: 22100.000 Interval: 10 Design Off: 41.317 Stk Off: (H) 0 (V) 0 Z: 20.09 CL Off: 41.317

< 0:1 > 2:1

DITCH

Slope Stake

Note that when picking the first ditch point left side, that the layer is Ditch, and the next two are layered Ditch1 and Ditch2. Above the select Ditch point to the right is the third shoulder point on the left side, with SHLD2 as the ID. The next step is simply to click OK (green check) and start the normal stakeout process. Note also that you can Slope Stake (typically from the outer ditch point on the trapezoidal ditch, Ditch1 in this case).

Plan Fixed(Sim) 14 50 ft

XSCT Fixed(Sim) 14 40 ft

-41.317 DIT

Pt: 10 Desc: STA 22100.0 HT: 4.5

N:700243.7229 E:2624276.39 > Z:32.6036

HSDV:0.045 VSDV:0.094 Z:20.090

Dsg:22100.000 L41.317

Sta:22098.628 L20.007

Cut 12.514

OUT 21.309 FWD 1.372

Pt: 10 Desc: STA 22100.0 HT: 4.5

N:700227.8526 E:2624278.73 > Z:32.5823

HSDV:0.047 VSDV:0.097 Z:20.090

Dsg:22100.000 L41.317

Sta:22099.139 L36.041

Cut 12.493

OUT 5.276 FWD 0.861

It should also be noted that on most PCs with up and down - arrows, the 6 lines of cut and fill reporting can be reduced by using the down - arrow key. Tapping the up - arrow key restores the full 6-line display. (In PC Simulation, use F2 to minimize and F3 to restore the 6 lines). This works in both plan view and section view. You can also drag the graphic display down and back up with a press and hold on the lower graphic window border. This is a little more difficult as the selection of the press and hold must be relatively precise, since normal press, hold and move impressions in the graphic area are interpreted as the pan command.

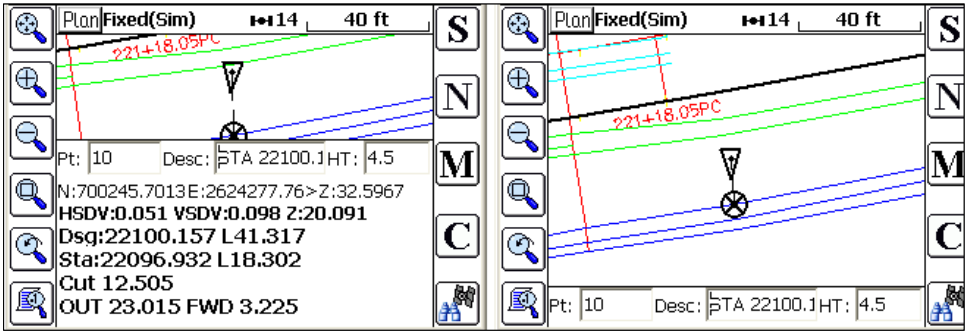

The amount of reduction in text and expansion of graphics is dependent on View Settings. To shortcut to View Settings, tap C for Configuration (or the Tools icon for Configuration) and select the View tab shown below. The above right mode is Collapse Mode "None". Below, Collapse Mode "Navigate Data" is shown, which is 2 lines. The position mode is also 2 lines and shows the x,y,z coordinates of the triangle (your position in the field). The PCDemo version of SurvPC can be expanded and collapsed, according to the Collapsed Report setting, using F2 to shrink and F3 to expand.

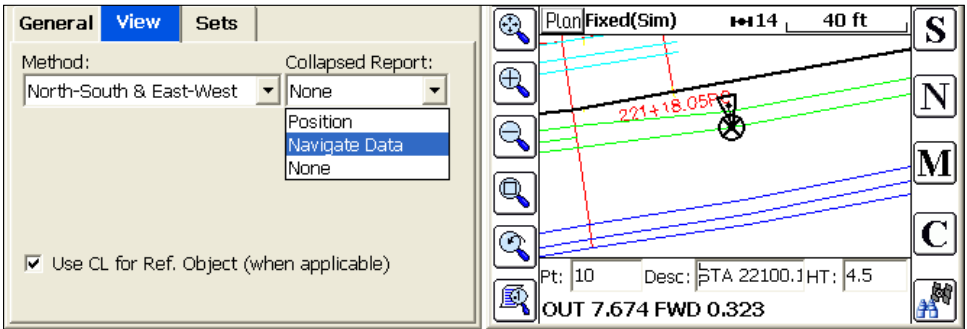

The Cut from Alignments method also allows use of the "Add" button to individually assign a centerline and profile to section points, but this method is tedious and rarely applies, compared to the method of selecting 3D polylines by pick and window/crossing selection from entities on the screen.



Plan Fixed(Sim) 14 410 ft

Pt: 10 Desc: STA 22100.CHT: 4.5  
 N:700143.8470 E:2624287.99 > Z:32.5866  
 HSDV:0.054 VSDV:0.101 Z:20.090  
 Dsq:22100.000 L41.317  
 Sta:22104.232 L120.383  
 Cut 12.497  
 IN 79.066 BACK 4.232

Graphics Data Display

Point Label Settings

Freeze All Font Size  
 Small  Large

Pt ID  
 Elevation  
 Description

Symbol  
 .  +  x

Set Attribute Colors  Use Decimal as Pt Loc

Only Display Last Stored Point (Alt+F)  
 Auto Zoom  UCS Icon  
 Draw Trail

When "Auto Zoom" is clicked on, the program zooms closely as the target is approached, leading to the bullseye (which appears whenever the target is within the Stakeout Tolerance set within Equip Menu, Tolerances.

Plan Fixed(Sim) 14 1 ft

Pt: 10 Desc: STA 22100.CHT: 4.5  
 N:700222.4144 E:2624278.78 > Z:32.5974  
 HSDV:0.048 VSDV:0.088 Z:20.090  
 Dsq:22100.000 L41.317  
 Sta:22100.049 L41.402  
 Cut 12.508  
 IN 0.086 BACK 0.049

Graphics Data Display

Point Label Settings

Freeze All Font Size  
 Small  Large

Pt ID  
 Elevation  
 Description

Symbol  
 .  +  x

Set Attribute Colors  Use Decimal as Pt Loc

Only Display Last Stored Point (Alt+F)  
 Auto Zoom  UCS Icon  
 Draw Trail

The "Story Stake" information would appear as shown below (Progressive and Total options). By staking Section ID "Ditch", there are 2 Ditch ID points to the left and 2 shoulder and 1 Center point to the right, up to the selected centerline. If "Show Report up to Center" is turned off (in effect, show ENTIRE report), then a much more complete report would appear providing offset information to all section points on both the left side and right side of the road.

Offset PT		Sta:	Offset:	Elevation:
22100.000		L41.250		32.599
	HDIST	VDIST	SLOPE	
DITCH2 to DITCH1	3.88	1.94	CUT	50.0% 2.0
DITCH1 to DITCH	5.00	0.00	FILL	0.0% 999.9
DITCH to OFFSET	0.07	12.51	FILL	999.9% 0.0
OFFSET to SHLD2	25.75	0.40	FILL	1.5% 64.6
SHLD2 to SHLD1	5.50	0.04	CUT	0.7% 139.6
SHLD1 to CENTER	10.00	0.07	CUT	0.7% 143.5

Offset PT		Sta:	Offset:	Elevation:
22100.000		L41.250		32.599
	HDIST	VDIST	SLOPE	
OFFSET to DITCH2	8.95	10.57	CUT	118.1% 0
OFFSET to DITCH1	5.07	12.51	CUT	246.9% 0
OFFSET to DITCH	0.07	12.51	CUT	999.9% 0
OFFSET to SHLD2	25.75	0.40	FILL	1.5% 64.6
OFFSET to SHLD1	31.25	0.36	FILL	1.2% 86.9
OFFSET to CENTER	41.25	0.29	FILL	0.7% 142.



## Road Model

The LandXML Road Model, when loaded, requires selection of a main horizontal and vertical alignment. The routine then processes similar to Cut from Alignments, described above. The LandXML format for road design files is widely recognized around the world as the accepted form of file sharing. Carlson Software is the principle sponsor of LandXML.org beginning in 2014. In Scandinavia, for example, roads are often defined by a series of horizontal and vertical alignment "pairs" for each road breakline (edge-of-pavement, shoulder, etc.) and a single file can contain multiple roads, and all surfaces of each road (top, subgrade1, subgrade2, etc.). As an example, a portion of an actual LandXML file might appear as shown here, which includes the road name "316" in this case:

```
</Project>
<Alignmentsname="316">
<Alignmentname="316" length="971.597307" staStart="0.000000">
<CoordGeom>
<Linelength="27.309619" staStart="0.000000">
<Start>6581158.362094 151616.365550</Start>
<End>6581180.578173 151632.248280</End>
</Line>
<Spirallength="35.731361" staStart="27.309619" rot="ccw" spiType="clothoid"
radiusEnd="600.000000" radiusStart="INF" constant="146.420">
<Start>6581180.578173 151632.248280</Start>
<PI>6581199.957122 151646.102688</PI>
<End>6581209.848914 151652.738602</End>
```

Etc.

When the LandXML file is loaded, all the roads appear in a list, along with all subgrades.

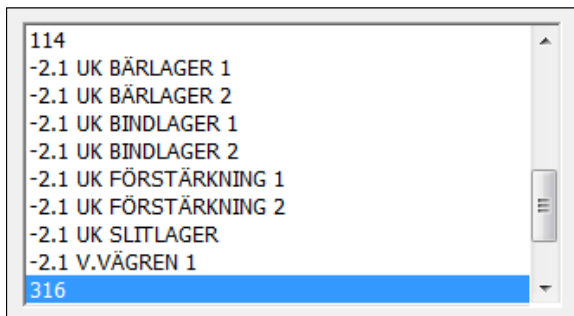



You then select any road to stake out, such as "316" in this example. Within the selected road, you can pick any surface (much like in the Cross - section method) and any point on the surface. If available, the description of the selected surface point is shown:

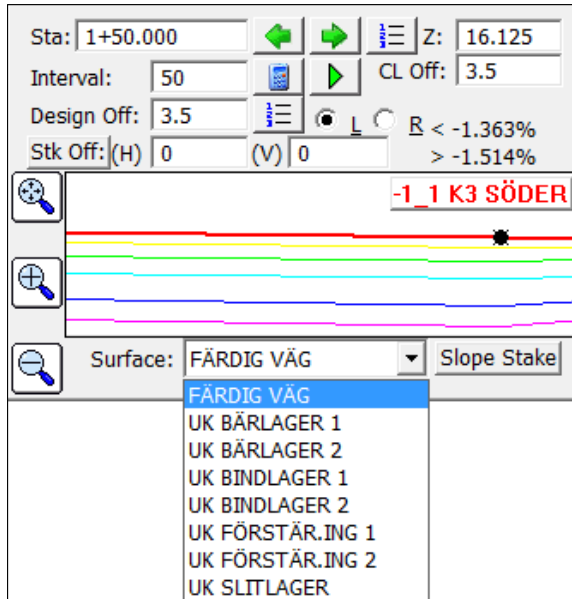

### Interpolation

If descriptions are provided, "intelligent" interpolation is performed between similar descriptions on slope transitions or widening lanes as well as vertical curves for all methods described above.



## Stake Road Screen (Common to All Methods)

This screen is the heart of the program. Here is where you select the station and offset to stake out. You can even launch into a slope stake and then return to stake out other template points.

Offset	Elev	Description
× -10.0000	838.3869	L305_1
Ⓜ 0.0000	839.1669	CENTER
× 10.0000	839.9469	R305_1
× 14.0000	840.2589	R305_2
● 18.0000	840.5709	R305_3
× 26.0000	837.9043	R305_4

- **Settings:** The “Additional Stake Stations” that appear in the List are set in the lower portion of the dialog. The Vertical Scale option will allow for “exaggeration” of the vertical on the template graphic. Though defaulting to 1, we can double the exaggeration by setting this to 2. In fact, an exaggeration of 5 works fine for the “demo.tpl” template file. The “Next Station Method” governs how “N” for next, from the stakeout graphic screen, moves you up. When set to “None”, N for Next will stay put until you change your entries. But if set to “Next Offset (Left to Right)”, Next will stay on the current station and move to the next offset. The “Next” in the dialog below, however, always increments the current station by the next station in the List. Don’t confuse the Next button on this screen, with the N button on the graphic screen to follow, which is influenced by “Settings”, and moves you along after you complete each point stakeout.
- **Station:** The value of the Station to Stake.
- **Interval:** The horizontal distance to increment the stationing when using the Next and Previous buttons.
- **Play/Pause:** This button allows the user to play through the road file like watching a drive-through movie.
- **List:** Depending on the settings and specified interval, “List” will list the defined stations including intervals and critical stations.
- **List Offsets:** This dialog allows the user to pick from the known offsets by a list rather than using the graphic screen below. It also allows the user to select an optional second point of “Reference” for reporting cut/fill information while staking. So, you could stake the shoulder but also reference cut and fill to the centerline, as an option. With this option, the selected offset and the secondary reference offset will both be reported to.



The resulting plan view in stakeout shows cut and fill to both the reference and the target point.

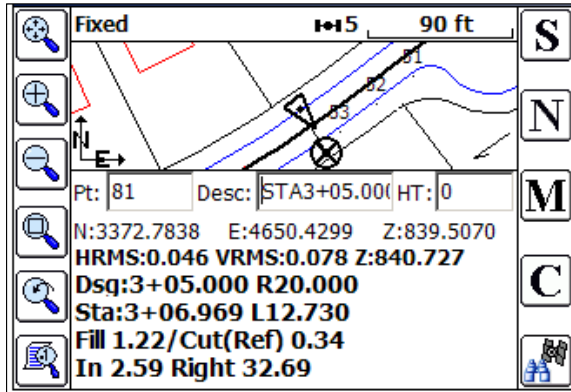

- **Design Offset:** Any offset can be entered, even if it is not a “break point” on the template. For example, an offset of Left 5 (-5) or Right 7.23 could be entered. For every design offset point selected, the elevation is calculated and presented. You can select the offset point from the offset list or literally pick it on the screen. The touchscreen is active in the graphic, so you can select the -12 (EP) just by picking it. Picking on the graphic screen will take you to the “Offset List” screen for verification, where you can confirm your pick by pressing Enter or selecting another offset.
- **Stk Off(H):** Horizontal offset from the design offset. If you enter a stake offset of 2 and the design offset point was at 12, then the stake would go in at offset 14 off of CL, but the cut/fill would refer to the elevation at the design offset location of 12. The stake offset and Off. to CL inter-react. A stake offset entry of 15 with a design offset of 12 left calculates to a setback of 3. If you click the "Stake Off" button, you can choose from a variety of methods to create an offset point, including extend current slope, apply next slope, vertical offset, or user-defined slope.





Horizontal Offset Distance  
 Horizontal  Slope Distance:

Vertical Options  
Extend Current Slope [v] [R]

Vert. Diff:  Slope:

Design Off: R 18  
Elevation: 840.7269  
Stake Off: SD 2.0061  
 Display as Ratio

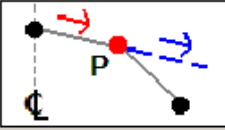

Your offset is then computed and shown graphically:

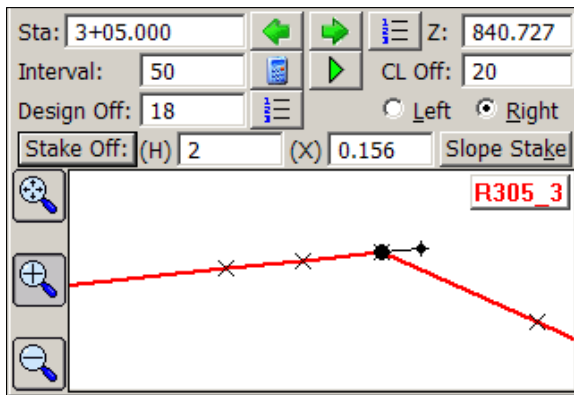

Note that you can zoom and pan in the dialog above. Pan using your finger or stylus.

- **Stake Off Button:** This button allows the user to specify the horizontal and vertical offsets relative to the design offset. Various methods can be used for computing the offsets based on the template or section points and their elevations.
- **Off to CL:** This is the total distance that the stakeout position is from the defined road centerline.
- **Vert. Off (V):** Vertical offset from the design elevation.
- **Elevation:** Elevation to be staked. This value is based on the combined design elevation and vertical offset.
- **Run Slope Stake:** This feature allows for dynamic slope staking in the middle of the Stake Road routine. This option is very useful for road staging, and also for staking interior catch points like central median ditches. When the slope stake is completed, the program returns to the main Stake Road dialog. Any point in the template or section can be used for running in a slope stake. You are asked to



specify the desired cut-and-fill slope ratios. The slope can be auto-defined or user defined as follows:

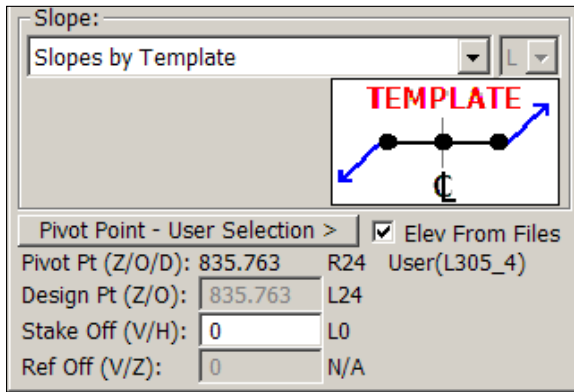

**Define Slope by Next Section Point:** This option allows you to select the edge of the road and use the proposed design catch point for auto-determining the slope rate.

**Define Slope by Previous Section Point:** This option allows you to select the proposed design catch point and then use the next point toward CL for auto-determining the slope rate.

**Extend Current Slope:** This option will allow you to pick the edge of the road or catch point and use the next point toward CL to end the slope between then away from CL.

**User Defined Slope:** Allows you to enter the slope ratio by hand for on-the-fly slope changes.

**Slopes by Template:** This option extracts the slope definitions from the template file itself.

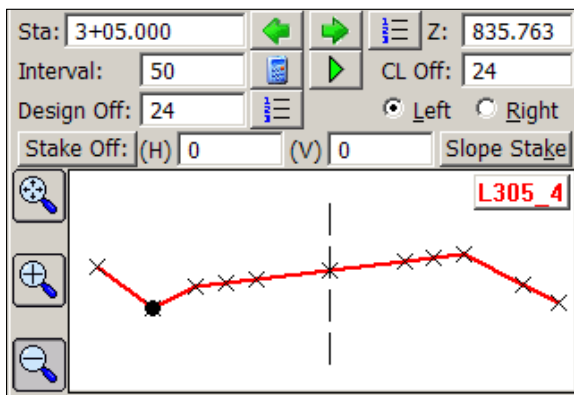

If you click Slope Stake, you can stake by the template slope for the ditch shown on the left side, or you can enter a user-defined slope to override what is in the template.



- **Pivot Point:** This option allows the user to perform on-the-fly offsets relative to the stakeout position.

### Stakeout Views

Stake Road now allows you to navigate to the point in either plan view or cross-section view. Select the helmet icon and choose Section to see a section view and choose Plan to return to plan view.

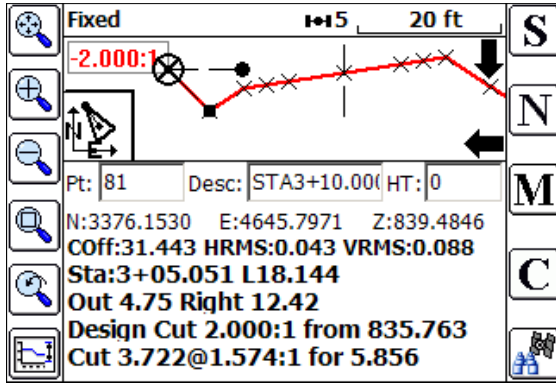

### Cutsheets

Stake Road will produce Alignment-style cutsheets that include the option to report station and offset as well as the cut and fill to any point. These are fully described in Stake Line/Arc, Elevation Difference and in Job Settings, Stake Tab. If using Slope Stake within Stake Road, a slope stake report, including "progressive" and "total" distances to all template or section points, can be output. On the first screen of Stake Road, the "Store Stake" option can be selected, leading to "Story Stake" style Cutsheets (basically cut and fill reports on one side or both side of the cross-section at all break points). Using the Grade Stake Method (see below), special Grade Stake cutsheets can be produced.

### Grade Stake Method

Regardless of the selection used to define the road (Design Files, Sections, Cut from Map Alignments or Road Model), the Grade Stake Method can be used for stakeout by clicking the "Grade" option at the top of the road stakeout screen, shown below:

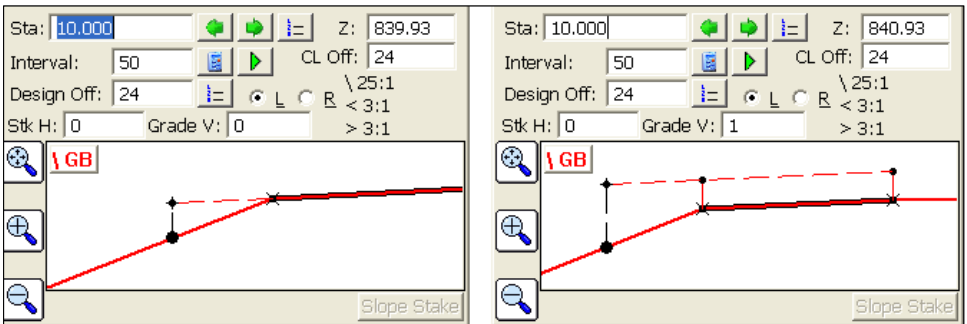
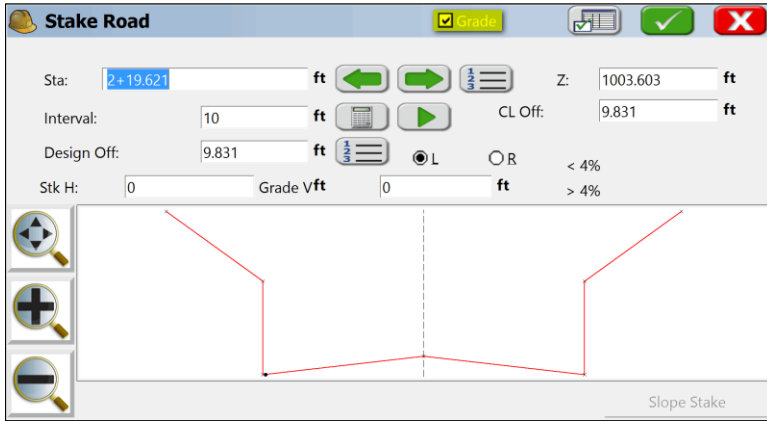

This option is popular in places like Australia and the UK. When you enter an offset like 24 Left (shown above), you can then pick any grade on the selected side by tapping the screen, typically closer to centerline, and that grade will extend to the offset shown. The goal is to mark the grade stake with a line representing the extended slope. You can also add an offset to the vertical grade as shown at right. The process involves 3 quick steps: (1) click Grade at the top of screen, (2) select an offset, (3) pick a grade on the screen to extend and stake.

The grade stake can be placed anywhere. You can place the grade stake on the left side of the road and extend the grades on the right side of the road as shown below.

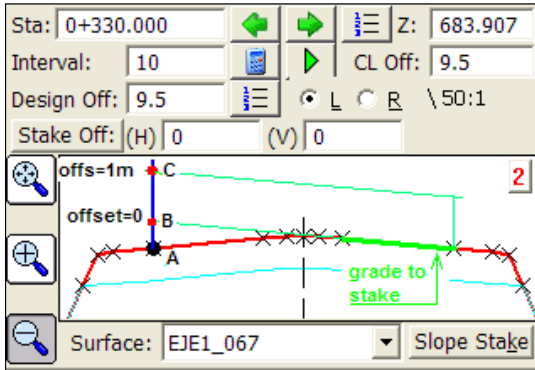

Point A is the position of the targeted grade stake, and the goal is to mark the stake by extending the slope of the selected grade (green one) where it intersects the vertical position of the stake (point B for vertical offset=0). You normally use a vertical offset when using grade stake (here shown as 1 meter) to find point C intersection. This methodology offers a handy way of checking a grade by placing the eye at the 0 offset of the grade and sighting down the grade, to verify if the slope is perfect, tangent to the line of sight.

When you click OK, you will be guided to set the Design Offset, the Grade Stake, and when on the point, you will obtain the cut or fill (typically fill value) to mark on the stake to match the extended grade (lower green line with zero offset, upper green line if a (V) or vertical offset is entered). You also have the option to position the stake anywhere on that station, since as you move in and out on the section, the program calculates the extended slope at your offset location. You could choose to place the stake at offset left 8.0 units, and you would get the cut/fill for that location. Cut and fill is computed from the bottom of the pole to the extended surface in green (either B, or C if an offset was used). If the pole is placed on top of the grade stake itself, then the cut/fill is to the top of the stake. In the graphic below, if you drove the stake at your current location, measuring up 1.01 would match the projected, extended grade, and the base of the pole is just 0.01 below the extended surface grade with no vertical offset.

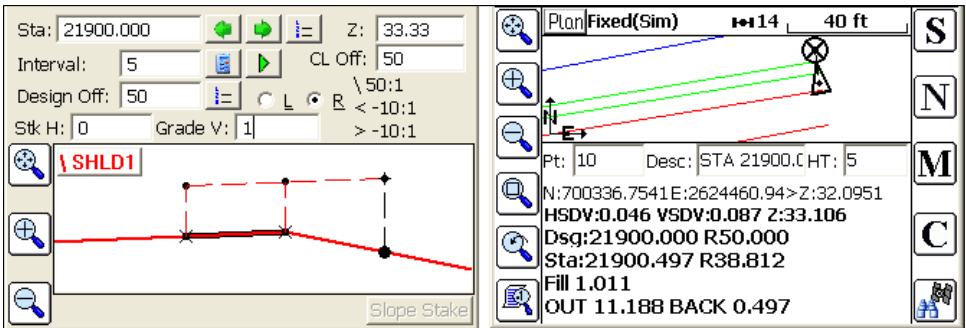



Opposite the "Design Offset" setting is a "From List" button, allowing you to pick the Design Offset to use. Click on this option and note that when using the Grade Stake Method, an extra "Grade" option appears for selecting and reviewing the offset segment in use.

The screenshot shows the software interface with the 'From List' button circled in red. The 'Design Off' is set to 50. The 'Grade V' is set to 1. The 'Slope Stake' graphic shows a red line representing the grade with a dashed line above it. The table on the right lists offset segments with their elevations and descriptions.

Offset	Elev	Desc
36.0000 to 42.0000	32.0400 to 32.1700	ROAC
42.0000 to 46.0000	32.1700 to 32.2500	SHLD
46.0000 to 60.0000	32.2500 to 30.8500	SHLD
60.0000 to 74.0000	30.8500 to 32.2500	DITCH
74.0000 to 78.0000	32.2500 to 32.1700	SHLD

Note also that the grade segment slope is reported in the upper highlighted slope percent or ratio (as configured), and the slope at the design offset (50) or grade stake position is shown, both left and right of the selected position (in this case 10% or 10:1). Configuration of ratio vs slope can be set by clicking the Settings button at the top of the dialog, then going to the Road tab. The outer ID of the selected grade segment is presented in the upper left as "\SHLD1". The ID of the Design Offset to Stake is presented in the upper right of the graphic screen, as in "Ditch". When the selected Design Offset is not a section or template break point (e.g. 50 below), no ID is presented in the upper right.

The two screenshots show the software interface with different design offset settings. The left screenshot shows the 'Design Off' set to 50, with the slope at the design offset highlighted as <math>10\%</math> and <math>10:1</math>. The right screenshot shows the 'Design Off' set to 60, with the slope at the design offset highlighted as <math>2\%</math> and <math>10\%</math>. The 'Slope Stake' graphic on the right shows a red line representing the grade with a dashed line above it, and the ID "DITCH" is visible in the upper right corner.



The Grade Stake method produces its own "Cutsheet" file or report of cut and fill. The Grade Stake report can be configured in Job Settings, Stake tab. Here is a report for stations 21900, 21905 and 21910, and shown in full below by using Excel to display the comma-delimited file, SC31GS.txt:

Item	On/Off	Header Label
Grade Off	ON	Grade Off
Grade Width	ON	Grade Width
Grade Slope Ratio	ON	Grade Slope Ratio
Grade VOff	ON	Grade VOff
Grade Elv1	ON	Grade Elv1
Grade Elv2	ON	Grade Elv2
Grade Design Elv	ON	Grade Design Elv

Header Label:  Update Item

Cutsheet from Raw  On/Off Down Up

Design ...	Design Off	Fill	Grade Off
21900.000	Right 50.000	1.233	Right 46.000
21905.000	Right 50.000	1.228	Right 46.086
21910.000	Right 50.000	1.260	Right 46.172

Insert Up Down Delete Special

A	B	C	D	E	F	G	H	I	J	K	L	M
#Design Sta	Design Off	Design Elev	Stake Elev	Cut	Fill	Grade Off	Grade Width	Grade Slope Ratio	Grade VOff	Grade Elv1	Grade Elv2	Grade Design Elv
21900	Right 50.00	33.33	32.098	1.233	Right 46.000	4.50.000:1			1	32.25	32.17	33.331
21905	Right 50.00	33.334	32.106	1.228	Right 46.086	4.51.282:1			1	32.258	32.181	33.334
21910	Right 50.00	33.339	32.079	1.26	Right 46.172	4.53.333:1			1	32.267	32.192	33.339

It is worth noting that Slope Staking from the command Stake Road is disabled when in Grade Stake mode, since the two features are not related. Simply turn off Grade Stake method to re-activate the Slope Stake button.

Grade Stakes can even have a Horizontal Offset as shown below. On this right side of road Grade Stake example, a -3 horizontal offset tilts the stake point in towards centerline, to the left. The resulting station to stake is 21915. This is essentially the same as entering 21915 directly.

Sta: 21915.000	Z: 33.343
Interval: 5	CL Off: 50
Design Off: 53	1.825%
Stk H: -3	Grade V: 1
	> -9.998%

XSCT Fixed(Sim)	14	8 ft
*50/SHLD1		
Pt: 10	Desc: STA 21915.CHT: 5	
N: 700345.1940	E: 2624444.69	Z: 32.1076
HSDV: 0.036	VSDV: 0.084	Z: 33.343
Dsg: 21915.000	R50.000	
Sta: 21914.994	R50.006	
Fill 1.236		
IN 0.006	FWD 0.006	



The circle with the X inside is the final target point, illustrating the effect of both a horizontal and vertical offset. That is where you would place the stake and mark the projected cut fill point on the stake or record it as text. Again, you don't need to set the stake at the target point--you know the cut and fill of the projected slope wherever you are, as long as you stay on the correct station. As you move left or right on the correct station, the design elevation is calculated at that offset (it appears to the right of the HRMS value above, as 33.343). Your actual pole reading is the Z:32.1076. So, the fill here is 1.236, represented by the vertical black line from the solid circle (your current position) to the projected slope (shown in red). You can drive a stake there and mark a line 1.236 above the ground, to represent the projected slope at 1 vertical offset. But if you were at offset 45, the design elevation would be calculated at offset 45 and the fill would still be valid. If Fill is reported, you would drive the stake and measure up from the ground the fill distance, to mark the stake. Fill is from the desired red projected grade to your ground position. If Cut is reported, then you are above the projected slope, and you would need to simply note the cut on the stake, since the projected slope cannot be marked on the stake.

When Grade Stake is turned on, be aware that when returning to the Stake Road command, the "Grade" option will be default on. Turn it off to use Stake Road in the conventional way.

### Story Stake Cutsheet Example

The Story Stake Cutsheet Report, is a report of cut and fill (see Job Settings, Stake tab, Cutsheets option). The term "Story Stake" means that the entire "story" of the cut and fill, across the entire cross - section (or up to centerline only if so configured) can be reported based on a single offset point staked on the road. The story stake report shown below will be created using cutsheet configuration tools.

Design Sta	Hub Offset	Hub Elev	Cut
1+000.000	Right 4.986	28.404	
TIE	29.014		5.504
DL	23.014		8.404
SH	15.014		2.604
EP	7.014		2.104
CL	4.986		1.904

Insert Up Down Delete Special

In this report format, each station takes up a row including the actual point staked, which in this case is renamed "Hub Offset" and "Hub Elev". Then below this row, each offset description appears, including the offset distance and cut/fill from the field-staked point (note the centerline is the same distance as the Hub Offset). This simple and useful format is configured as follows:





Referring to the opening screen of Stake Road, turn on "Show Story Stake Report". Prior to entering the Stake Road command, within Job Settings, Stake tab, Cutsheet option, under the Story Stake option, choose Select File, enter a new file name (for the story stake "txt" file) and then update as shown below. Use the "Up" button to move up the fields needed for the report. The "Desc" field is optional, and the report shown above omits it. Note how the default "Staked Elv" is changed to "Hub Elev" using the "Update Item" option at the bottom of the dialog. Click "On/Off" to turn off all selected items below the "Fill" option. Target only 6 "On" items, or 5 if "Desc" is omitted.

Item	On/Off	Header Label
Design Sta	ON	Design Sta
Desc	ON	Desc
Staked Off	ON	Hub Offset
Stake Elv	ON	Staked Elv
Cut	ON	Cut
Fill	ON	Fill
Staked Sta	OFF	Staked Sta

Header Label: Hub Elev | Update Item

Cutsheet from Raw |  On/Off | Down | Up

The "Hub Offset" on the first line appears as "Right 4.986". This "Right" or "Left" (vs R or L) is configured by clicking Settings in the "Cutsheet" opening dialog within Job Settings, Stake tab. The "Store Grade ID Only" works very well within Stake Road, Cut from Alignments, since the Grade ID is captured from the layer name of the selected entities. Grade IDs can also be entered using Road, Utilities, Input-Edit Section File. These Grade IDs are then displayed beneath the Design Station, in the first column, based on this setting. Configure as shown below to obtain the above report:

Stored Story Stake Report

Slope Stake:  Progressive  Total  Combo

Stake Road:  Progressive  Total

Store Grade ID Only  Add Off Value

Show Report Up to CENTER

Include Slope Stake Report as Notes

Offset Prefix: Left: Left Right: Right



### Slope Stake Cutsheet Example

Slope Stake is an option within Stake Road. Using the same "Cutsheet Settings" shown above (in Job Settings, Stake Tab, Cutsheets option), as it applies to "Slope Stake", the "Store Grade ID Only" option, clicked on, leads to the slope stake report shown below. Note the key first 3 elements which need to be configured when creating the Slope Stake cutsheet file (Design Sta, Desc, Pivot Off). Just like with the Story Stake, the "Store Grade ID Only" places the section ID underneath the first column "Design Station" but goes further and places the Horizontal offset from the staked point under "Desc" and the vertical offset under "Pivot Offset", leading to a very simple and useful report. In this example, the catch point is a "top of slope" point above the ditch, which explains the positive vertical offsets to the ditch and even to the shoulder point.

Stored Story Stake Report

Slope Stake:  Progressive  Total  Combo

Stake Road:  Progressive  Total

Store Grade ID Only  Add Off Value

Show Report Up to CENTER

Include Slope Stake Report as Notes

Offset Prefix: Left:  Right:



## 9 Map

This chapter describes the use of the MAP screen. The MAP screen commands are available in the pull-down menus or at the command prompt. The MAP screen is useful for drawing, COGO, creating points for stakeout, and for the import and export of DXF and shape files. No measurements are taken from the MAP screen.

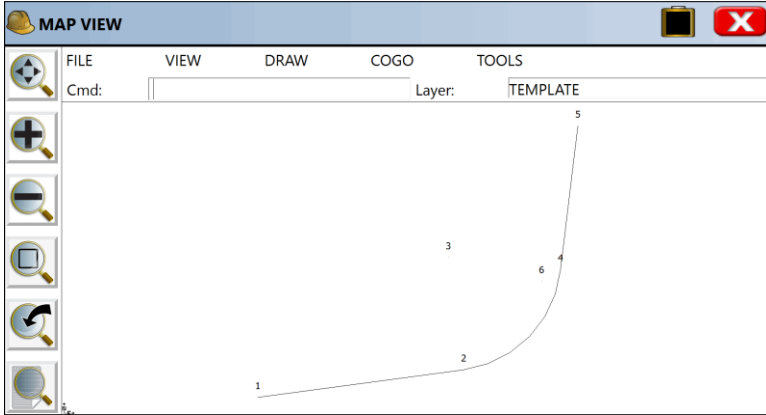



## 9.1 Basics



The MAP screen is accessed by tapping the globe icon in the upper right of the main menu. The basic operations of the MAP screen are described here.

### Map View Icons

The commands associated with the MAP View Icons are described in the figure below:

	Zoom extents: Zooms to the extents of the map, showing all points and objects.
	Zoom In: Zooms in 25%.
	Zoom Out: Zooms out 25%.
	Zoom Window: Zooms into a rectangular area that is picked on the map screen.
	Zoom previous: Zooms to the previous view, SurvPC remembers up to 50 views.
	Opens the View Point Options dialog.

The View Options button in the lower left opens up a 3-tab dialog with many additional settings for viewing points. For example, you can display just the Point ID, or you can turn on elevation and description display. With the elevation display on, you can even make the decimal place on the elevations be set as the point location, to save screen space.



By default, points are black, elevations blue and descriptions green, but these color assignments can be changed with the option "Set Attribute Colors". Point fonts can be made large and you can also show a Scale Bar in addition to the WCS Icon. If description is clicked on but there is no description, none will be displayed.

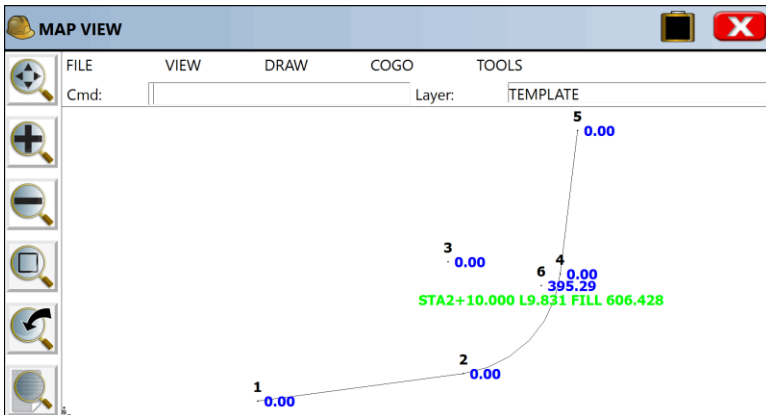
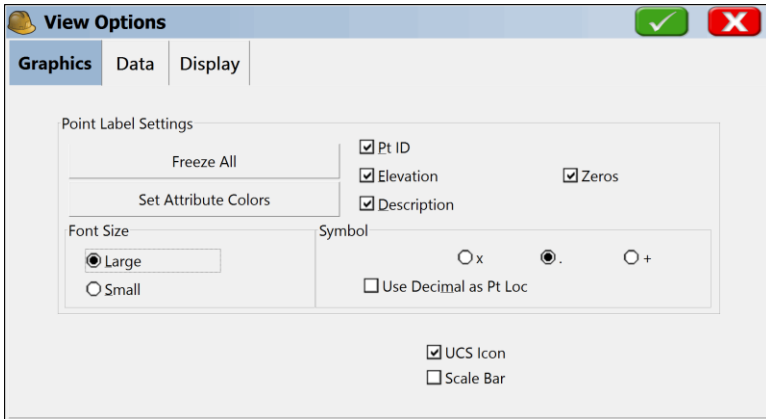



Clicking the Data tab brings up "Intelligent Zoom" and Traverse Defaults. Intelligent Zoom, if turned on, makes selection of points easier. If you are inversing between points or selecting points by clicking them on the screen, Intelligent Zoom detects distinct clusters of points and zooms to those clusters for easier selection, rather than bringing up a long list of points to choose from after clicking. Since this only applies to point selection, keeping Intelligent Zoom on is generally a good idea. Regarding Traverse Defaults, this option enables zenith angle prompting as you traverse or sideshot in the Map screen. It also sets whether hand-entered, Map screen traverse and sideshow entries are stored to the raw file.

The Display Tab allow for an option 'Use South as Reference', this will allow the user to use South as Reference. This option works in combination with Azimuth options-found under Job Settings. The Azimuth can range from 180 – 0 degrees.

### Executing commands in Carlson MAP

The MAP screen defaults to a pull - down menu format containing over 90 additional commands, virtually doubling the number of commands found in the Menu Screens. Many of the commands in MAP offer CAD-like features such as layer freeze and thaw, predetermined area, polyline offsets and even contouring. One of the most important commands is Polyline to Points, which allows you to create points for reference or for stakeout (set out) from any selected polyline. The MAP screen also includes a command line format that can be set using Preferences. Several MAP screens pull - down menu commands involve "fly out" options, as shown below.

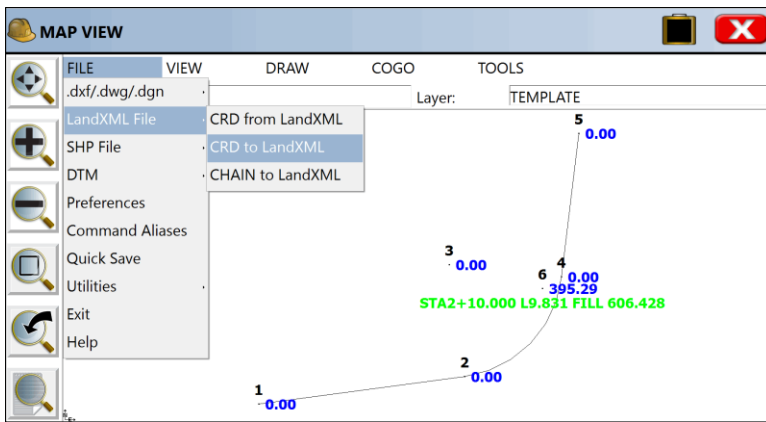

Alternatively, you can enter the command name, or command alias, at the command prompt and press ENTER. In many cases, the user can start a command while using another command. The newly started command is called a "transparent" command. Each command from the left-toolbar menu is a "transparent" command.

Usually, a command does not immediately execute. Carlson MAP either displays a dialog box or displays prompts at the command line requesting more information from the user. Typically, the user can select objects on the screen or enter data on the command line. Many commands consist of a series of options, structured as follows:

Cmd:Command name-Option1/opTion2/opTion3/.../<default option>



To select one of the options, the user can enter the entire option name or only the capitalized letters, and then press ENTER. If available, the default option always appears in angle brackets (<>). To select the default option, just press ENTER. If no command is active, the user can repeat the previous command by pressing ENTER.

### Panning the Screen

The user can move the drawing display (PAN) anytime. To use this command, the user must hold down and slide a finger — or the proper pointing device — on the screen. The drawing display is moved in the same direction as the pointing device. When you release the pointing device, the panning stops. Only the display moves and all objects retain their correct coordinates. Be careful to start the pan by picking in “empty” space. If you hold down on a point, you may obtain the “Point Details” screen, or you may see a list of points to select from (to see Point Details). If you hold down on a line, you may see the "Line Details" screen.

### Point Details

Unless you are in the middle of a MAP screen command, you can click on a point and see a Point Details dialog. If you tap near several points, a list of nearby points will appear from which you can select the target point. Otherwise, you will go straight to Point Details, and see a screen that includes the option to delete or edit the point.

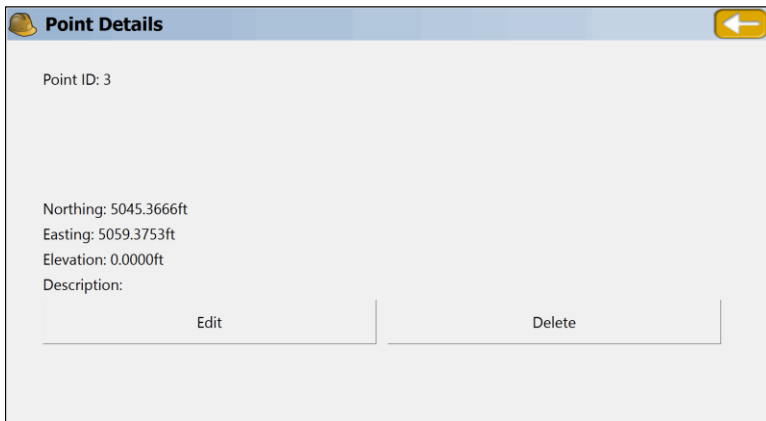

If you are in total station mode, and actively surveying (with a setup and backsight specified), clicking on the setup or backsight point will lead to a special graphic, as shown here:



**Point Details** 

Point ID: 1



Northing: 4959.8023ft  
Easting: 4942.2812ft  
Elevation: 0.0000ft  
Description:

[View Attributes](#)

**Point Details** 

Point ID: 2



Northing: 4976.6498ft  
Easting: 5068.7853ft  
Elevation: 0.0000ft  
Description:

[View Attributes](#)

If you have assigned attributes to the points (e.g. Description Pole, Type-Metal, Wires-4, etc.) by use of the Feature Code capabilities, these attributes can be reviewed. The Point Details option works both within the MAP screen (when you are not being prompted for entering points or selecting objects) and in all graphic screens within the Menu options. It is not as transparent and available as the dynamic pan option, but nearly so.





## Line Details

Unless you are in the middle of a Map screen command, you can also click on a line and see Line Details. Clicking the line at the lower edge of the drawing (a blue ditch line) leads to a simple Line Details display:

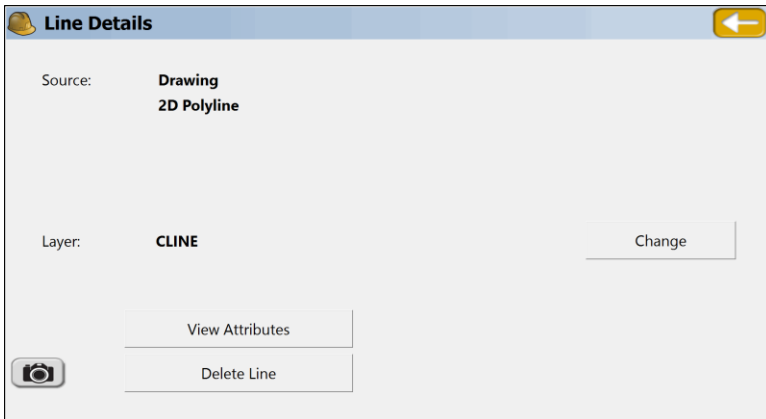
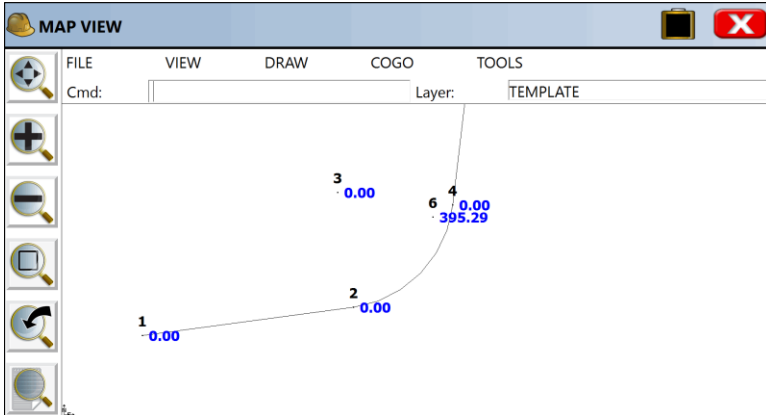

You have the option to delete the line or change its layer or View Attributes (if any). If the polyline (a line with 2 or more vertices) has different elevations on some of the vertices, then it is designated a "3D Polyline". A more advanced Line Details is provided when using Feature Codes within the Store Points command, allowing extension of lines and new lines from vertices on the polyline. The advanced Line Details is discussed under File, Feature Code List.



## Control Points

Control points can be used in the Map Screen. To use control points, you must have the setting 'Use Ctrl Pts for Map Selection' enabled (found in Equip, Configure, General Tab). Then, in the map screen, during any map command the option for Ctrl Points will be available to use in that map command.

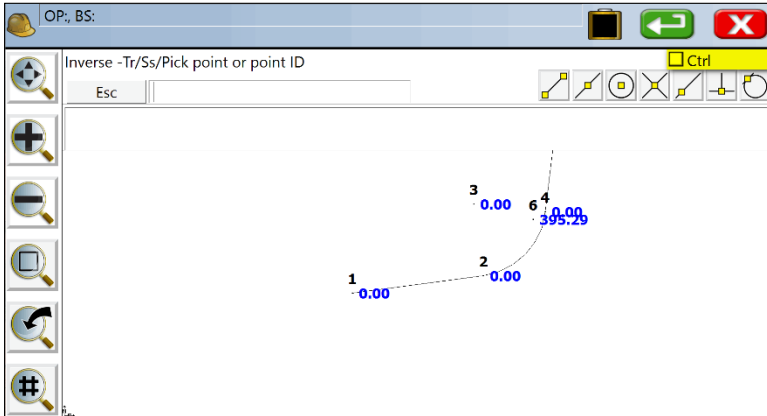



## 9.2 File

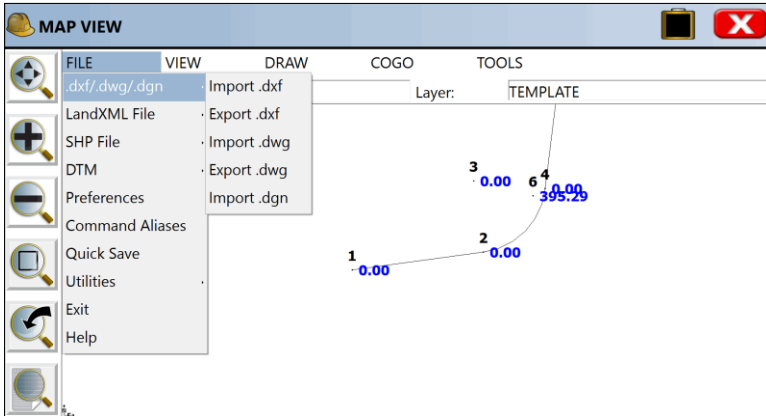

### DXF File - Import DXF (IDXF)

Similar to the AutoCAD(r) DXFIN command, will bring in polylines from AutoCAD, Microstation, Terramodel and other products that can export data into a DXF file format. Text can be imported. Blocks under 256k are imported and can be selected or "snapped to" using the node or center snap (if a circle). For block or text importing to work, turn on "Allow Import .dxf/.dwg/Esri Options" within Job Settings, Options, in the File Menu. See discussion in Import DWG.

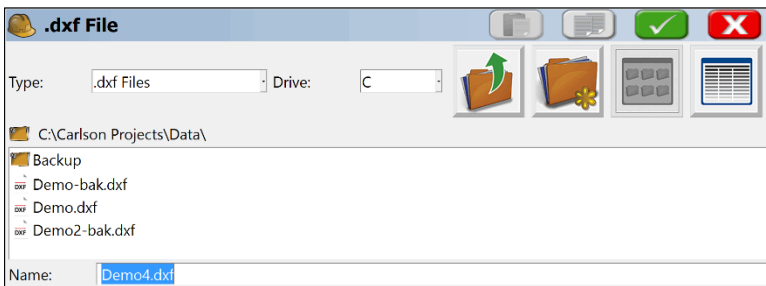



## DXF File - Export DXF (EDXF):

The **EDXF** command is useful for exporting files to Microstation, Autocad, Intellicad, ESRI and virtually all other CAD drafting programs. It provides controls for displaying points and also for displaying GIS attributes associated with points and linework.

The **EDXF** command, similar to the AutoCAD(r) DXFOUT command, will export a DXF file. It captures not only 2D and 3D polylines and their layer names but also exports all visible (layer on) points from the CRD file into AutoCAD "Point" entities form (layer PNTS). All points and polylines that are visible (layers on) would be exported, not based on the current screen zoom, but based on the full extent of the drawing.

Automatic DXF Save / Export will automatically detect if the data loaded or created in the current job will not be acceptable by AutoDesk R12. If not acceptable, and AutoDesk 2000 DXF file will be created.

The **EDXF** command has many special features for displaying the points in the exported drawing. Consider the source drawing below:

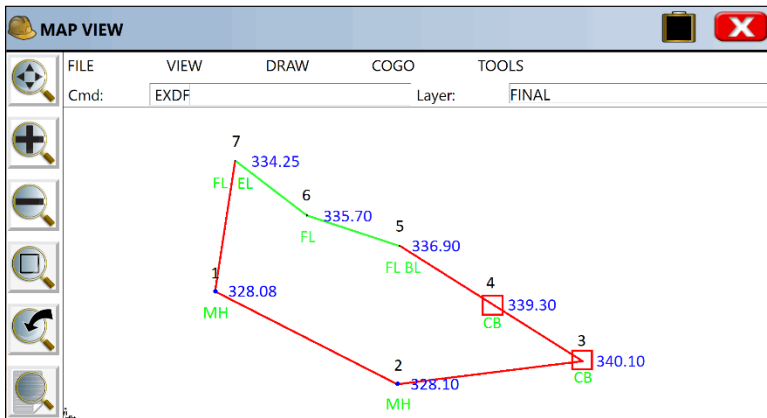

When the Export DXF command is issued and a file name is entered, a dialog appears with options shown below. If you choose "Create block attribute on layer: 0", then all attributes such as point number, elevation and description take on the layer of the node. In this case, all point attributes inherit the fence line layer for the fence points and the utility layer for the catch basin and manhole points. If you do not put the attributes on layer 0, then they have distinct colors and layers for the number, elevation and description. In addition, if you click on "Save GIS Point Feature to Block", then if GIS attribute data is included, this data will appear beneath the description in a vertical, left-justified column (e.g. 5.4=depth, 2=number of inlets, Cast Concrete=type).

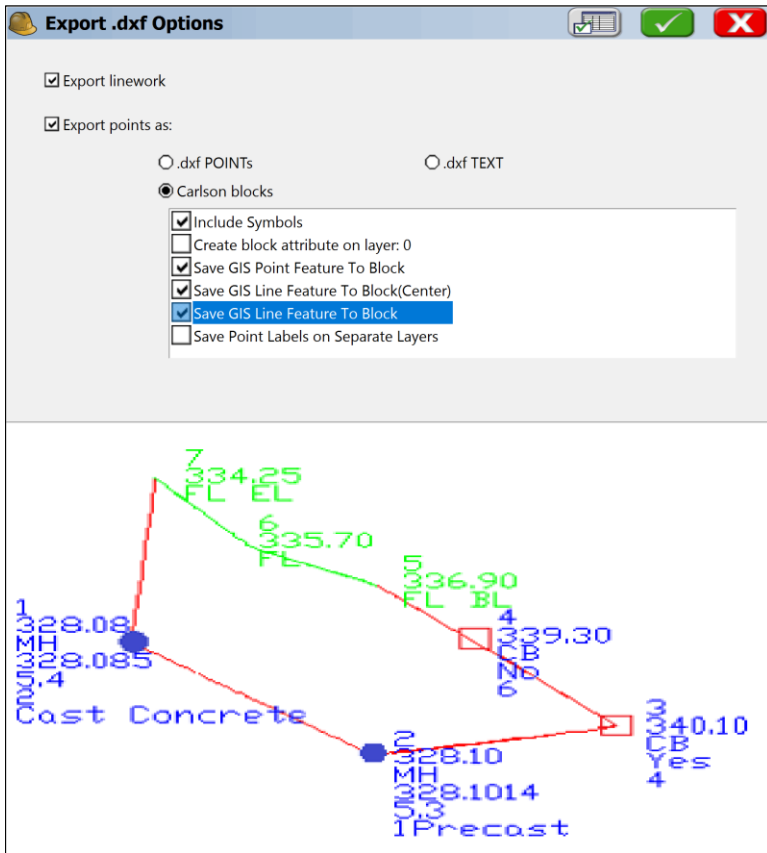

If the points are exported as Carlson blocks, then they will move as one object within CAD, when selected.



Another option is to export the points as ".dxf text" in which case each distinct piece of text can be selected, moved and edited.

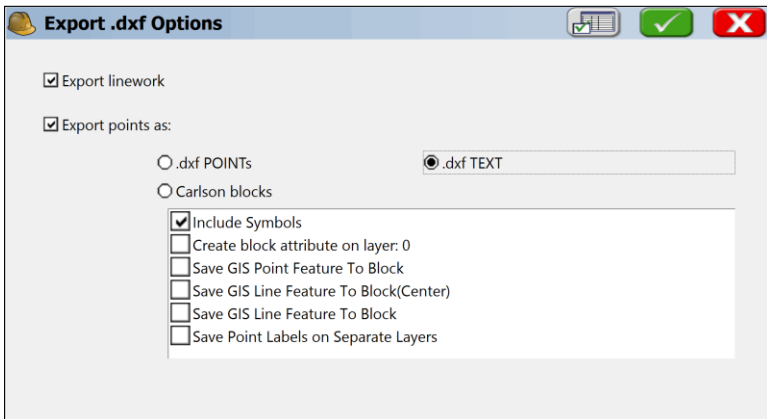
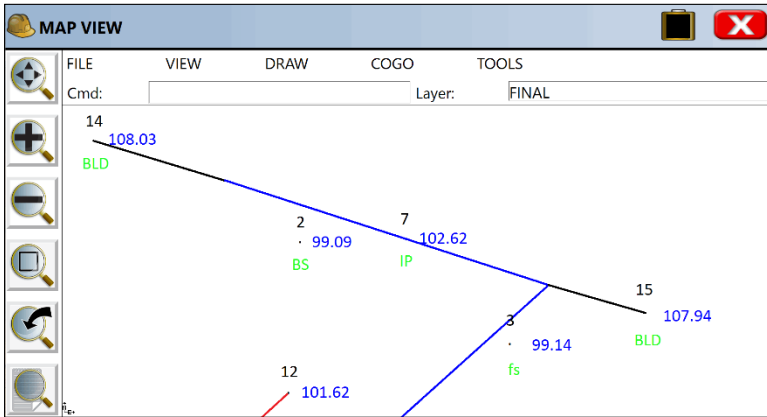



Click the settings button at the top of the screen to change the text height and row spacing for the text. In the example below, we've moved the description of point 15 above point 15, since it can be selected and moved individually. Note that solid, circular point symbols import as basic circles. All points are imported with a node to snap to within CAD, even in "AutoCAD text" mode.

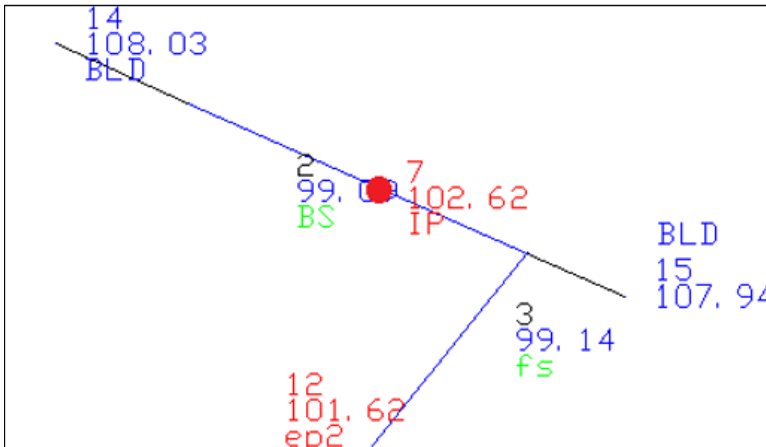
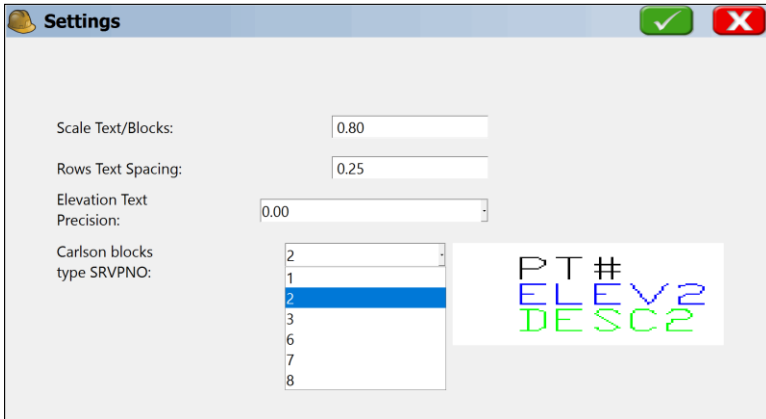

Other options in the command include drawing GIS line feature attributes and Saving Point Labels on separate layers. If "Save GIS Line Feature to Block (Center)" is clicked on, then attributes associated with a polyline will draw in the middle of the longest segment of the polyline. If "Save GIS Line Feature to Block" is clicked on, but the "Center" option is not clicked on, then the GIS attributes of the polyline draw on the second point of the line, below the other "standard" point attributes such as elevation and description.

Shown below is the combination of normal point attributes (not placed on layer 0) and linework GIS feature plotting, shown associated with the second point in the polyline.



**Export .dxf Options**

Export linework

Export points as:

.dxf POINTS       .dxf TEXT

Carlson blocks

- Include Symbols
- Create block attribute on layer: 0
- Save GIS Point Feature To Block
- Save GIS Line Feature To Block(Center)
- Save GIS Line Feature To Block
- Save Point Labels on Separate Layers

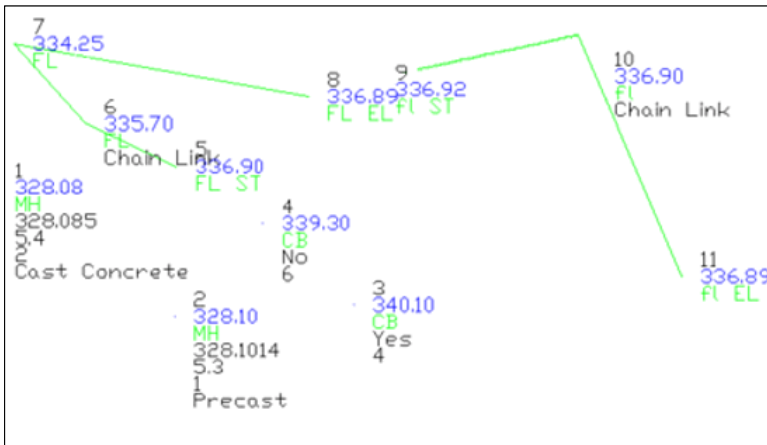

The "Save Point Labels on Separate Layers" option places the exported points on the layers associated with the point descriptions, as defined in the Feature Code List. If "EP" points are defined as going on the "Road" layer, then when exported to CAD as a DXF file, these EP points will be on the Road layer, and BLD points associated with the "Building" layer will be on the "Building" layer in CAD. In this way, the exported points can be turned off an on by use of layer commands.





## DWG File - Import .dwg (IDWG)

The IDWG command directly loads a ".dwg" file into SurvPC and all layer names are retained. Text and MText is imported but hatching is not imported. Only blocks under 256K, polylines and text will appear in SurvPC. Blocks such as symbols can be "snapped" to for stakeout using the node/center snap, which also serves as an insertion point snap. Text can be "snapped to" also using the node snap, in which case the text insertion point will be used. Be sure to go to File in the main menu, Job Settings, Options and turn on "Allow Import .dxf/.dwg/Esri Options". When these options are turned on, you obtain the following prompting when Importing:

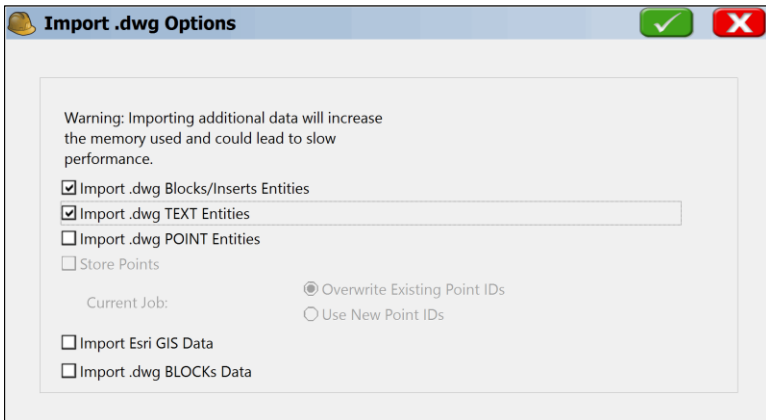

Note that Point Entities, points plotted in AutoCAD or in Carlson Survey and other Carlson products, can be imported and also stored as points within SurvPC.

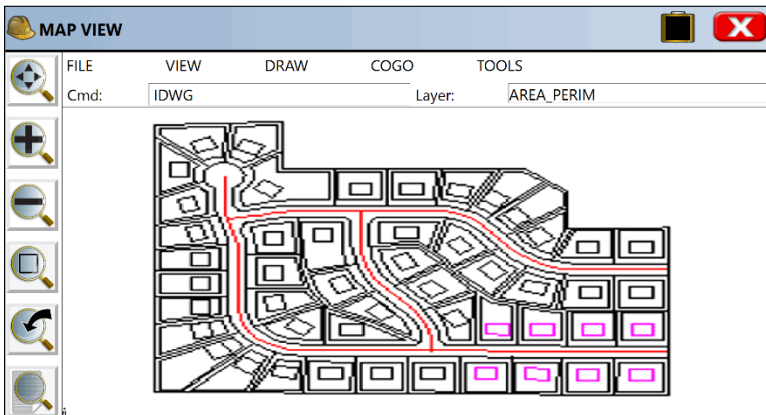



## Importing Blocks and Importing Text in the DWG file

Blocks that are used in Autocad or Intellicad or other CAD packages using ".dwg" formats like Graebert and Bricsys can be imported into Carlson SurvPC. For block importing to work, set Process Block/Insert on within File, Preferences. In the example below, the storm sewer inlets are shown as a "grate" symbol, in various rotations. Note that these symbols import into SurvPC 3.0 and higher directly, including with rotation.

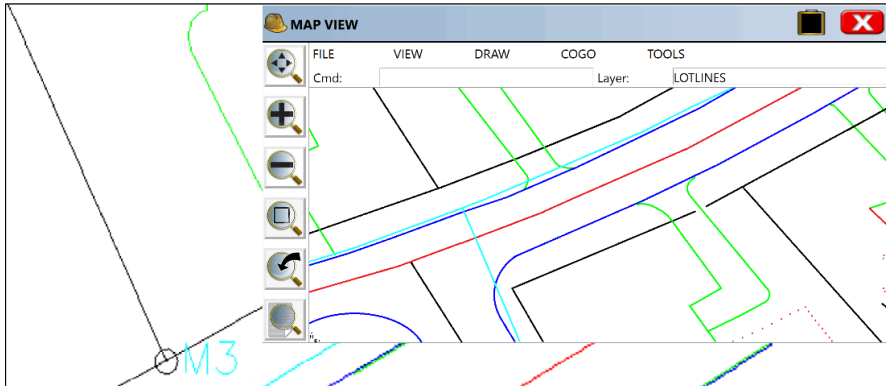

Note above that blocks with solid fill are imported as only the outline. Note also that the inlet grate near M3 in the .dwg file in CAD, at left, is imported with correct rotation. (Text was not imported in this example). All imported blocks can be staked out using the "cen" or "center" snap, which doubles as an "insertion point" snap. All forms of Text can be imported optionally with the exception of MText. Text created by the "Text" or "DText" commands import as shown below, using a single "Carlson" font style at present:

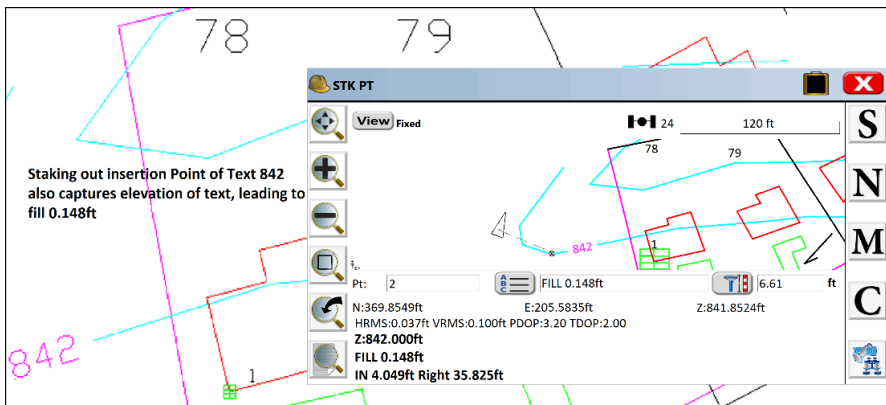

*Note: If a .dwg file is exported from ArcMap 9.1, 10.0 and 10.1 using the command "Export to CAD", then this form of a .dwg will import in SurvPC with all associated ESRI attribute data captured. This data can then be edited, and new features and attributes can be added to the map. Then the EDWG (Export DWG) command in SurvPC will return the full drawing with associated attributes back to Esri ArcMap 9.1, 10.0 and 10.1, when imported.*



### **DWG File - Export .dwg (EDWG)**

The EDWG will export to ".dwg" format all linework appearing in the SurvPC Map screen, regardless of origin (imported, drawn in the MAP screen, created by Field Codes). Layers and even line thickness (as created by field codes) will be retained in the exported drawing. The controls for exporting DWG files are similar to those of exporting DXF files described above, with two added options: (1) to designate the DWG format as shown below, and (2) to export MSC (metadata) in the .dwg file for import by Esri ArcMap version 9.1, 10.0 and 10.1.

The command Import from CAD within Esri ArcMap (9.1 to 10.1) will efficiently import all screen entities and GIS attributes and store them in Esri format. Maps and data can complete the full cycle by being exported from Esri using the command "Export to Cad", editing and added to within SurvPC, then exported back to Esri for importing.

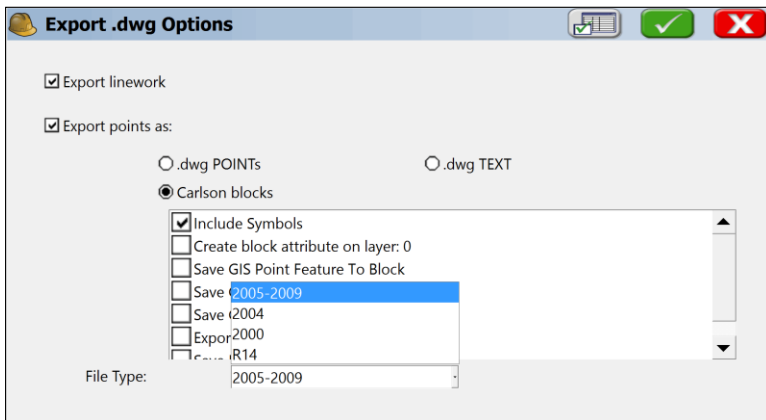

### **DGN File - Import .dgn (IDGN):**

Directly imports a Microstation .dgn file and stores the file in DXF format, the normal format of SurvPC.

### **LandXML - CRD from Land XML (XML2CRD):**

This command allows you to import points from LandXML format to SurvPC.

### **LandXML - CRD to Land XML (CRD2XML):**

This command allows you to export points from SurvPC to LandXML format.

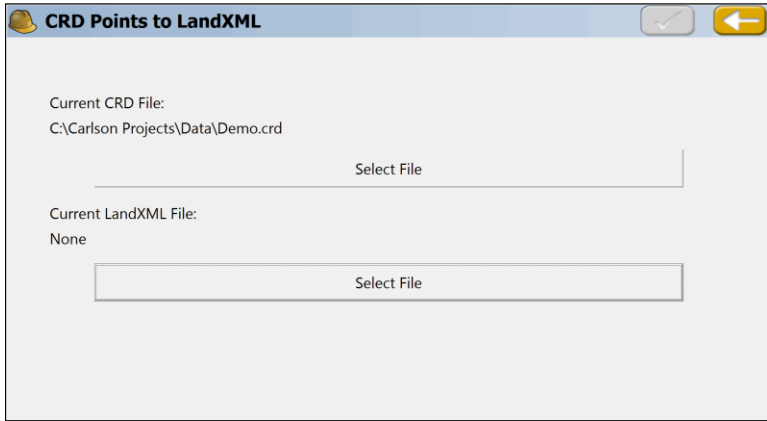

### **LandXML - Export Chain File to LandXML (CHAINXML):**

This command allows you to export all the polylines from the current drawing created using Feature Codes, as LandXML chain objects into a LandXML file. For example, if you made strictly 3D polylines for break lines using descriptions such as EP for edge-of-pavement or DL for ditch line, then the 3D polylines can be exported as a LandXML chain file and used as break lines for contouring in other CAD programs. The combination of points and break lines can lead to optimal contouring. Most CAD packages will import linework using the DXF file approach, but many now recognize linework in LandXML “Chain” file format.

### **SHP File - Import Shape File (ISHP) (e.g. from ESRI):**

This command allows you to import entities and also the associated attributes values from a SHP file. The routine displays "Import from SHP" dialog box. If the SHP file has POINT or POINTZ type, the entities will be stored into a CRD file. In the cases of an ARC, ARCZ, POLYGON or POLYGONZ SHP type, the entities will be stored into the current drawing. The attribute values will be stored into a \*.vtt file. The routine requires a feature code name from the user, which will be used to store the name and the type of the attributes from the SHP file. SurvPC supports import of SHP ESRI basic files, including measure type, to the Feature Class Definition (POINTM, POLYGONM, ARCM).



### **SHP File - Quick Import SHP (QISHP):**

This command allows you to import entities from SHP files (used by most programs produced by Esri). The routine displays the Import from SHP dialog shown below. POINT or POINTZ type entities will be stored in a CRD file. ARC, ARCZ, POLYGON, or POLYGONZ entities will be stored in the current drawing as POLYLINES.

**Quick Import from SHP**

Current SHP:   Type:

Current Job:

Overwrite Existing Point IDs  
 Use New Point IDs

Attribute used to fill Description Point:

Layer used to store new entities:

**Current SHP:** Displays the name of the SHP file that will be imported when this command is completed. Read-only, you must use the Select SHP button to specify the file name.

**Select SHP:** Tap this button to select a SHP file name.

**Current Job:** Available when importing coordinate data. Specify whether to Overwrite Existing Point Numbers or Use New Point Numbers.

**Attribute used to fill Description:** Available when importing coordinate data. Lists the attributes in the currently selected SHP file. Select which attribute to use to fill out the Description field in the CRD file.

**Layer used to store new entities:** Available when importing geometry. Select the layer to store the new entities.

**Process:** Tap the green checkmark to begin the import process. When complete, it will display, "Process done". Then click the orange back arrow to exit. If you are importing a large file, a progress bar at the bottom of the dialog will indicate the progress of the import.



## SHP File - Export SHP File (ESHP):

This command allows you to export entities from the current drawing and also the associated attributes values, into a SHP file (or more accurately, multiple shape files). The routine will allow the user to select which entities will be exported, based on entity type and also based on the feature code name. The routine displays "Export to SHP" dialog box.

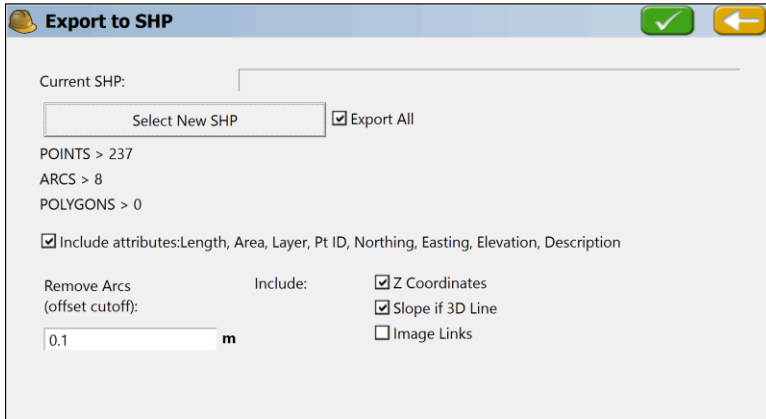

Click on Export All and include special attributes and optionally the Z coordinates. If you have point, arcs (non-closed polylines in Esri terminology) and polygons (closed polylines), all with one attribute, you will obtain up to nine files as shown below:

```
Ascot1_11.dbf
Ascot1_11.shp
Ascot1_11.shx
Ascot1_13.dbf
Ascot1_13.shp
Ascot1_13.shx
Ascot1_15.dbf
Ascot1_15.shp
Ascot1_15.shx
```

The selection of the Z coordinate places the 1 after the underline character. Otherwise, the file form would be, for example, Ascot1\_1.shx (special attributes only). The "1" group represent points, the "3" group represent arcs (unclosed polylines) and the "5" group represent polygons (closed polylines). Within Export Shape file, the field name in the dbf file is expanded to handle up to 254 characters.



### SHP File - Quick Export SHP (QESH):

This command allows you to export polylines and/or points to an SHP file. When first entering the command, you may be prompted for a "projection file", a .prj file, that allows the export to overlay on grid coordinates. The ".prj" file itself is made within Esri products. You can choose to use the current ".prj" file, use another, or cancel any use of a projection file, as shown below:

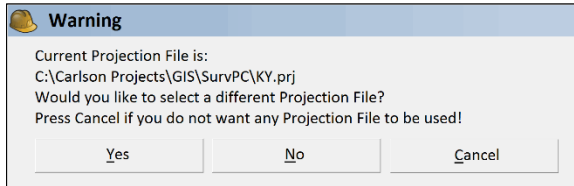

Then proceed to a dialog that displays the following options:

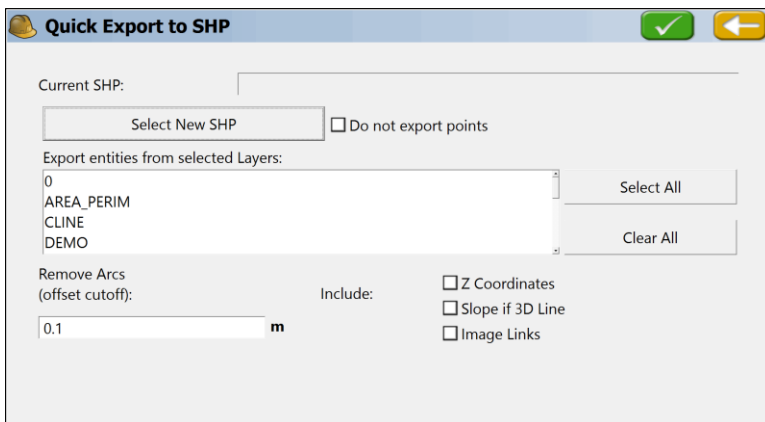

**Current SHP:** Displays the name of the SHP file that will be created when this command is completed. Read-only, you must use the Select new SHP button to specify the file name.

**Select new SHP:** Tap this button to select a SHP file name.

**Do not export points:** When this option is checked, only polylines are exported to the SHP file.

**Export entities from selected Layers:** Lists the layers in the current map. You may select certain layers for export.

**Select All:** Selects all layers in the list.

**Clear All:** Clears all selected layers in the list.

**Remove Arcs (offset cutoff):** Specifies the maximum distance that a vertex on a polyline segment will deviate from the original arc.

**Include Z Coordinates:** When this option is checked, elevation data (or Z coordinates) will be included in the SHP file.



**Slope if 3D Line:** If distinct, different vertice elevations are detected, you have the option to retain the starting elevation for all vertices or export the vertices with their distinct elevations.

**Process:** Tap the green checkmark to begin the export process. When complete, it displays, "Process Done". Then tap the orange back arrow to exit. If you are exporting a large file, a progress bar at the bottom of the dialog will indicate the progress of the export.

### Export ASCII w/GIS:

Allows exporting of points with attribute data in the form Pt ID, Northing, Easting, Elevation, Description, Attribute1, Attribute2, etc.

### DTM Import - DTM from DXF (TDXF):

Allows you to import 3DFACE entities from a DXF File and save them as a triangulation (TIN) file and also draw them as 3D faces.

**Import 3DFACE from .dxf**

DTM (\*.tin;\*.flt): None

Draw 3DFace entities

Select New DTM File

Select layer:

0	ON
AREA_PERIM	ON
CLINE	ON
DEMO	ON
DISTXT	ON
EXISTING	ON
FINAL	ON

Layer name: TRI\_FACE





### DTM Import - DTM from Land XML (TXML):

Allows you to import 3DFACE entities from an XML File and save them as a triangulation (TIN) file and also draw them as 3D faces.

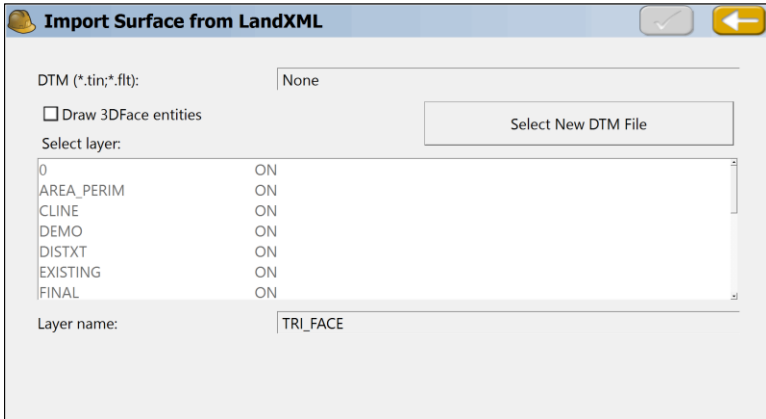

The DTM file is stored in SurvPC as a TIN file and can be used for commands such as Elevation Difference (obtaining cut/fill by comparing field measurements to the DTM).

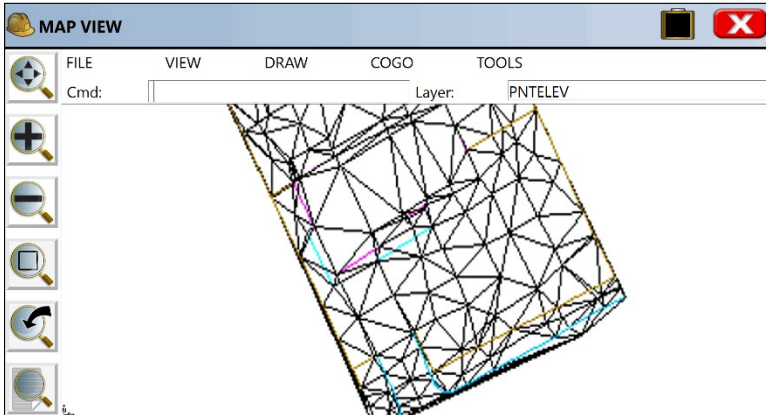

The 3DFaces are placed on a layer (TRI\_FACE by default), and that layer can be turned off and removed from view. If you choose E for Erase, you can pick the 3D Face entities and erase them on command. There is no particular value to seeing the 3D Faces, so it is not recommended that they be drawn. The main value is to capture the TIN (triangulation) file for use in Elevation Difference.



### DTM Export - DTM to LandXML:

Load a .TIN or .FLT file and export to LandXML format. The process typically takes place in less than 1 second. Click the back arrow to return to the Map screen.

### DTM Import - DTM from Ispol:

Allows you to import a TIN file from the Ispol format, commonly used in Spain.

**Preferences (SETT):** This allows the user to turn on/off the pull-down MAP menus. Menu Off is rarely used, provides more graphic space, but forces users to enter commands at the command line by typing them in (such as E for Erase). The graphic screen style of normal or reverse (solid dark) background is set here. Preferences also includes the setting "Sketch Option" which removes the "tangent" snap from the available snaps for selecting points on lines and objects and substitutes a "?" snap for sketched or randomly picked points on the screen, adding a new command "2D Sketch" under the Map Screen, Draw, Polyline options.

When the 2D Sketch is selected, then there is a snap option to pick in blank space on the screen, the snap to the right, seen as a "?". Any polyline drawn with the sketch "?" snap can be used for stakeout using conventional snaps. So, you could draw a new 2D Polyline to divide lots 78 and 79 by snapping to the back-property line (Nearest), picking a "?" sketch snap in the middle and ending with a perpendicular snap to the lower property line, as shown below. Then you could stake out the sketched point (pencil below) using the endpoint snap.

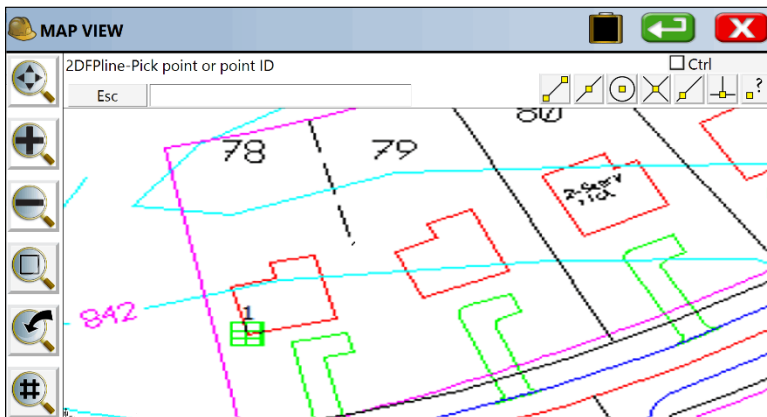
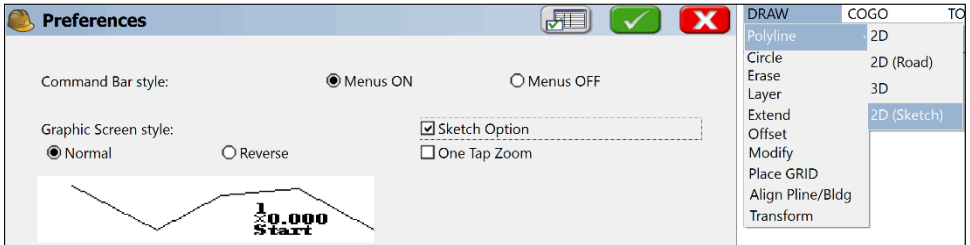



### Command Aliases (AL):

Brings up a list of commands in the MAP mode for which the user can substitute an alias. If you would prefer to type A for Area rather than AR, you can substitute “A” as an alias for AR. Three commands will not accept substitutes: Inverse, Traverse and Sideshot (I, T and S). In addition to commands, you can toggle over to the “Linework special code” option, and substitute aliases codes for the default special codes such as PC, PT and END (used to control linework using feature codes). As an example, you could choose the “X” or “..” to End a line, or use “CS” for curve start instead of PC. A list of MAP commands is shown below:

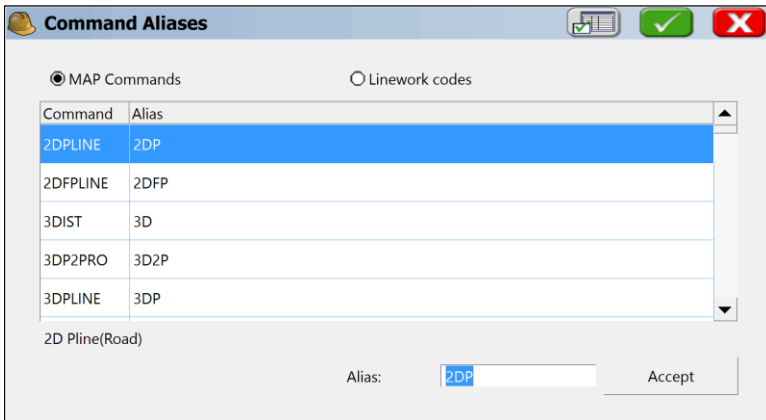



Command	Alias	Description
2DPLINE	2DP	2D Polyline
3DIST	3D	Bearing and 3D Distance
3DP2PRO	3D2P	3D Polyline to Profile (.pro)
3DPLINE	3DP	3D Polyline
ALIASES	AL	Aliases
ALIGNB	AB	Align Building 1-Segment
ALIGNBC	ABC	Align Building 2-Segment
ALIGNBSET	ABSET	Align Building Settings
APERTURE	AP	Aperture Size
AREA	AR	Compute Area
CHAINXML	CHAINXML	Chain of Polylines to LandXML
CHANGE	CHG	Change Layer
CIRCLE	CR	Draw Circle
CL2PLINE	CL2P	Centerline (.CL) to Polyline
CONV2D	C2D	Converts 3D to 2D
COPY	COP	Copy Entities
COPYGIS	CGIS	Copy GIS Data
CRD2XML	CRD2XML	CRD Points to LandXML
CURVCALC	CC	Curve Calculator
DELLAYER	DL	Delete layer
DRAWBLDG	DB	Line or L-Figure to Building
DRAWLP	DLP	Draw / Locate Points
DRAWMOSS	DMOSS	Draw / Import Moss File
DRAWPLN	DPLN	Draw / Import PLN File
EDITPL	DDP	Edit Polyline
ERASE	E	Erase Entity
EXIT	X	Exit
EXPSHP	ESHP	Export Shapefile
QEXPSHP	QESHP	Quick Export Shapfile
EXPDWG	EDWG	Export .dwg File
EXPDXF	EDXF	Export .dxf File
FLD2FIN	F2F	Reprocess Field to Finish
FILLET	F	Fillet 2 Lines – Create Curve
FIND	FND	Find Point
Help	H or ?	Help
HINGEDA	HA	Hinged Area
DXF2FLT	TDXF	Import DTM from DXF
IMPSPH	ISHP	Import Shapefile
QIMPSPH	QISHP	Quick Import Shapefile
XML2CRD	XML2CRD	Import LandXML to CRD
IMPDGN	IDGN	Import .dgn File
IMPDWG	IDWG	Import .dwg File
IMPDXF	IDXF	Import .dxf File
EDITGIS	EGIS	Edit GIS Data
INVERSE	I	Inverse (Distance)
ISOLAYER	IL	Isolate Layer
ISOLATE	ISO	Isolate Points
ISSMOOTH	ISSMO	Report Deflection in Plines



JOIN	JN	Join Polyline Segments
LIST	LI	List Entity / Report Layer
LISTELEV	LELV	List Elevation
LAYER	LA	View Layers
MIRROR	MIR	Mirror Entity
MOVE	MOV	Move Entity
NGSQUERY	NSGQUERY	NGS Query for Control Points
OFFSET	OF	Offset Type
OFFSET2D	O2	Offset 2D
OFFSET 3D	O3	Offset 3D
OFFSETB	OBUF	Buffer Offset
OFFBYSEG	OSEG	Segment Offset
TRDEF	TD	Traverse Defaults
POLYLINE	PL	2D Polyline
PLINE2CL	P2CL	Polyline to Centerline File
PL2PNTS	P2P	Polyline to Points
QSAVE	QS	Quick Save
REMARCS	RMA	Remove Arcs
REVPLINE	RV	Reverse Polyline Direction
ROTATE	ROT	Rotate Entity
SAVEASCRD	SCRD	Copy CRD File
SCALE	SCL	Scale Entities
SCALEBAR	SB	Scale Bar On / Top / Off
SIDESHOT	S or SS	Sideshot
SLIDINGA	SA	Sliding Side Area
SLPREP	SR	Slope Report
TRAVERSE	T or TR	Traverse
TRGCALC	TC	Triangle Calculator
TRCNT	TRGC	Triangulate and Contour
TRIM	TM	Trim
UCS	UCS	UCS Icon On / Off
VIEWOPT	VO	View Options
ZOOM	Z	Zoom
SETTINGS	SETT	Settings (Preferences)
DIVSEG	DVS	Divide Polyline by Segments
DIVINT	DVI	Divide Polyline by Interval
FLT2XML	T2XML	Export DTM to LandXML
XML2FLT	TXML	Import LandXML to DTM
WORLDIMG	WORLDIMG	Image Overlay
GIS2TXT	GIS2TXT	Export GIS to ASCII Text
DRAWGRID	DG	Draw Grid
TPP2FLT	TTTP	Import DTM from ISPOL Files
XBYDIST	XDST	Extend by Distance
XBYEDGE	XEDG	Extend to Edge
VOLUME	VOL	Volume Report

Linework and special "field-to-finish" codes are shown below:

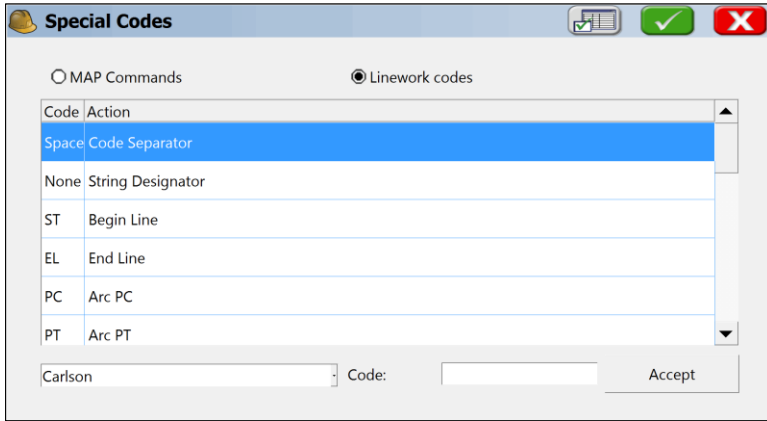

Code	Action
Space	Code Separator
None	String Designator
ST	Begin Line
EL	End Line
PC	ARC PC
PT	Arc PT
CLO	Close Figure
SMO	Smooth Line
JPN	Join Point
RECT	Close Rectangular
OH	Offset Horizontal
OV	Offset Vertical
NE	No Elevation
JOG	Extend by Distance
ZO	Elevation Only
AFIT	Arc Fit by Second Point
CIR	Close Circular
BFIT	Best Fit Line
BPRJ	Best Projected Points

The Settings button at the top of the screen applies to field-to-finish coding and is covered in the Feature Code List feature within the File menu.

**Quick Save (QS):**

Saves the current DXF file without prompting for the file name.

**Save As(SCRD):**

Saves the current coordinate file to the location you choose as a backup copy.

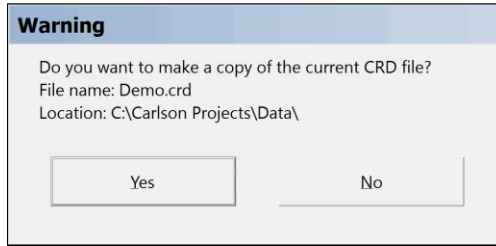

**Draw MOSS File (DRAWMOSS):**

This will import and draw a MOSS ".inp" file.

**Draw PLN File (DRAWPLN):**

This will import and draw a Carlson PLN file, which is a file of polylines and converted text, created in Carlson Survey or the Carlson Civil Suite.

**Exit (X):**

This exits the MAP and CAD session and brings you back to the Menu screen.

**Help (H):**

Launches the interactive Help screen describing various MAP screen commands.

Scroll up and down to review. With wireless on, includes access to Internet Explorer, by tapping the icon at the top of the Help screen. The Help screen is an HTML file which will appear if loaded on the PC.



## 9.3 View



The View menu is found next to the File menu in MAP view. Below you will find each feature described.

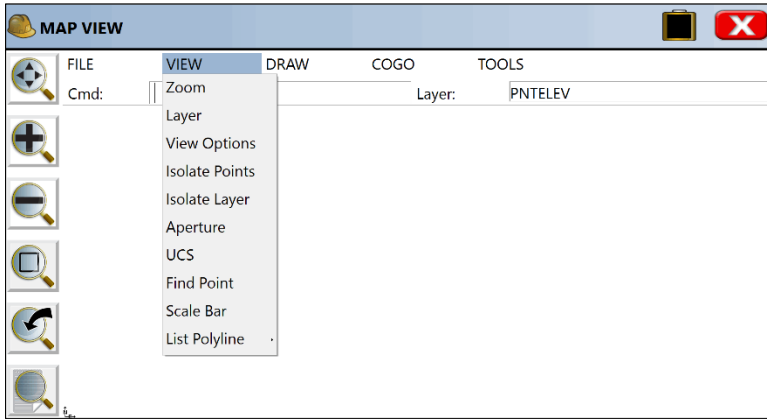

### **Zoom (Z):**

Increase or decrease the apparent size of polylines and distances between points, in drawing area. The specific options in the command are N (Zoom to Point ID/Number, enter zoom magnification), I (Zoom In), O (Zoom Out), W (Zoom Window), P (Previous) and E (Extents). The Zoom command options can also be accessed using the first 5 buttons from left-toolbar menu. The order of buttons, starting with the first top button, is: Extents, In, Out, Window, Previous. Zoom Previous will "nest" which means that if you Zoom In or Zoom Window 3 times, each Zoom Previous takes you back one step and 3 Zoom Previous commands would return to your original view.





### Fast Scale / Magnification

The map can be scaled quickly by clicking on the lower-right Scale. The user can then Select the new center (by point number or Map location) of the Map and type in the preferred scale for the Map View.

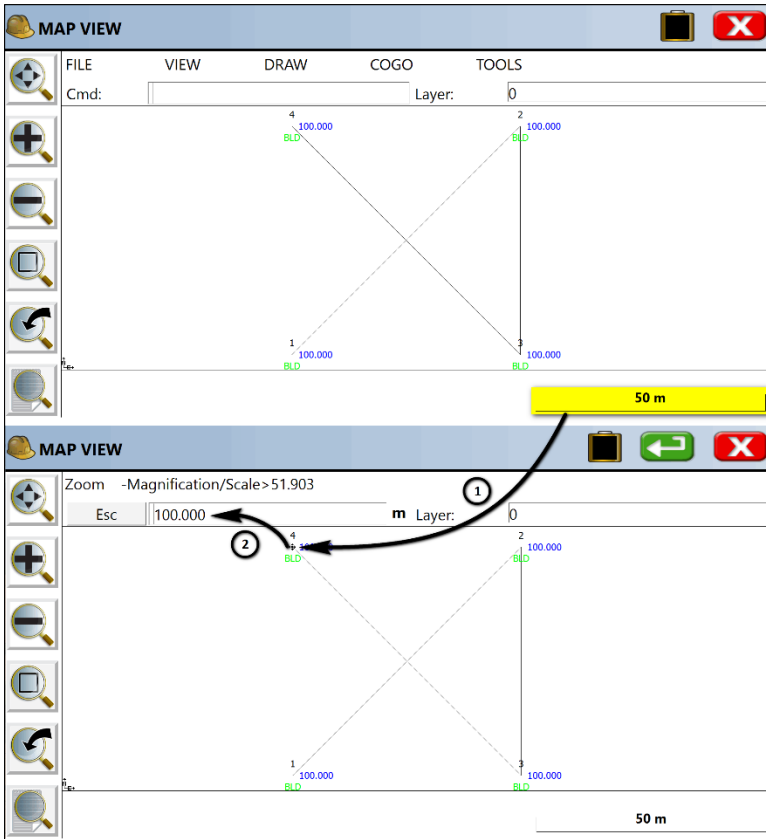



## Layer (LA):

This command manages layers and layer properties.

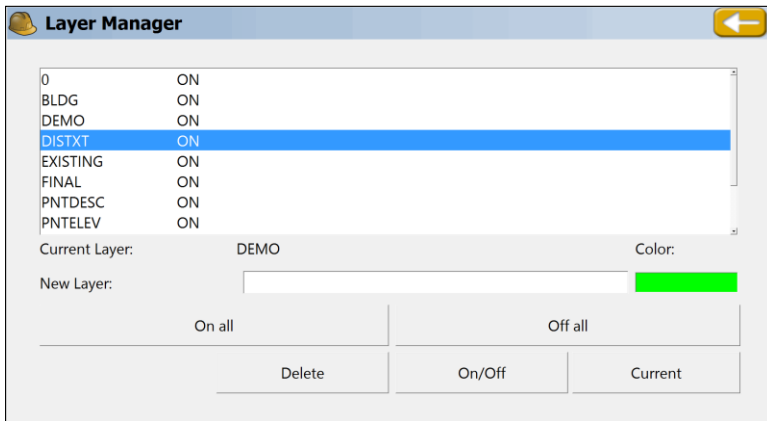

**Add a new layer:** Type in a new name into the New Layer edit box. The New button will appear at the bottom. Tap this button. If you type in a new layer name and the New button does not appear, then the layer name you entered contains invalid characters.

**Set a layer current:** Highlight the layer name in the list and then tap the Current button. You cannot set a layer current if that layer is turned Off. Turn the layer On first and then set it current.

**Delete a layer:** Highlight the layer name in the list and tap the Delete button. You cannot delete layers that contain objects. If you select a layer and the Delete button is not visible, then this layer contains objects.

**Turn a layer On/Off:** Highlight the layer name and tap the On/Off button. Objects on layers that are On will be visible, objects on layers that are Off are not visible.

**On all:** This button will turn all layers on

**Off all:** This button will turn all layers except the current layer off.

**Color:** Clicking on the color bar will bring up the color palette allowing you to set or change the layer color of the highlighted layer.

One of the main purposes of the Layer command is to permit the import, by DXF, of a drawing containing all possible polyline work to stake out (set out). Then you can reduce clutter on the drawing by turning layers off, leaving only the layers you want. You can stake any endpoint, intersection, or other location on the polylines using "snaps" without creating point numbers. You can also do the MAP command Cogo, Interpolate Points, Polyline to Points and make point numbers out of all vertices (corners) of polylines where you need to set stakes. Then proceed with Stakeout by Points.



## View Options (VO):

This command controls the appearance of point objects on screen. This is exactly the same as touching the lower left graphic icon. The routine displays the View Point Options dialog. Pt#, Description and Elevation toggles control whether these attributes are labeled with the points. If Freeze All is on, the points are placed on the map, without attributes. Available point symbols are: ".", "+", "x". The "Decimal is point location" toggle determines if the decimal point used in the display of elevations represents simultaneously the point location and symbol. This slightly reduces screen clutter. Turning on the WCS Icon and Scale Bar would show the north direction and graphic scale at all time in the MAP view. Turning them off also reduces screen clutter.

Small and Large toggles determine the size of font used to display the point object on screen. Set Color Attributes brings up the color palette (available only on color CE devices). This lets you choose the color of the point symbol, elevation and description text. Traverse Defaults is found under the Data tab, which also includes the "Intelligent Zoom" toggle ("on" setting recommended). The Traverse Defaults button brings up a dialog that has the settings for prompting each time for instrument and rod height and the vertical angle. This applies to the T for Traverse and SS for Sideshot commands that allow point calculation within the MAP Screen. For Cogo work, turn off Instrument/Rod Height and Vertical Angle prompting. For manual entry of actual field measurements, turn them back on.

**View Options** [Green Checkmark] [Red X]

**Graphics** | Data | Display

Point Label Settings

Freeze All

Set Attribute Colors

Font Size

Symbol

Pt ID

Elevation

Description

Zeros

Large

Small

x

.

+

Use Decimal as Pt Loc

UCS Icon

Scale Bar

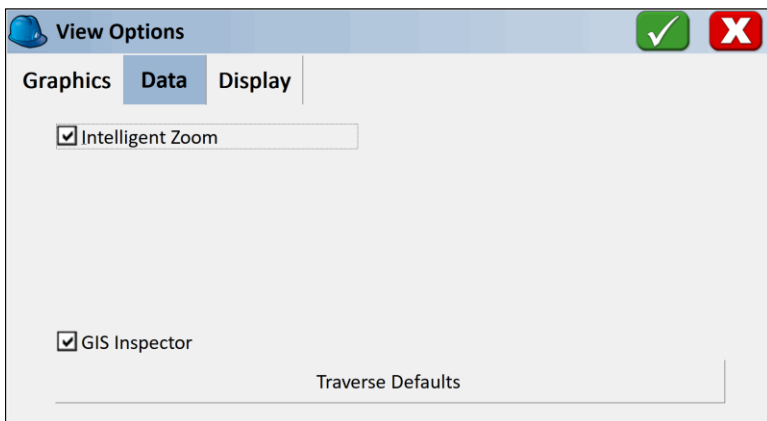
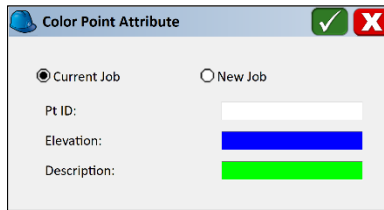
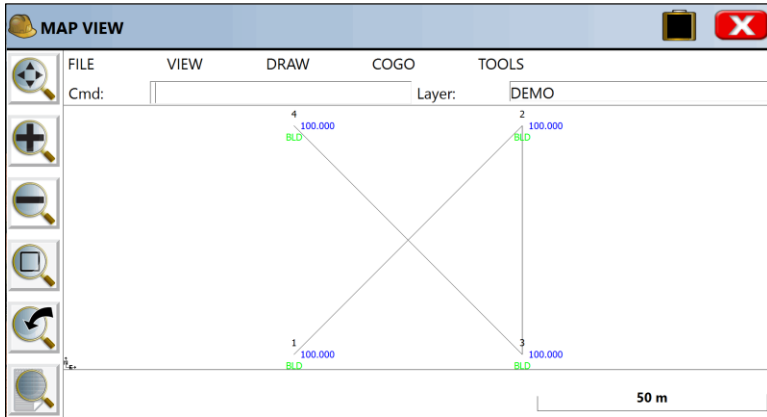

**GIS Inspector:** The option allows for creating and viewing points with attributes directly from the map screen. Once enabled, simply click on any point in the map screen to view / edit the GIS Attributes. This will also prompt the user to add attributes when adding any new point using CAD commands.

*Note: to View or Edit attributes of a polygon, click anywhere inside the polygon.*



**Traverse Defaults**

Prompt for:

Instrument & Rod Height

Vertical Angle Prompt:

None

0 Degrees Level

90 Degrees Level

Elevation Difference

Raw File:

On  Off

The Display tab is covered in the Map-Basics section of the manual, and allows for rotation of the map screen to any cardinal direction (N,S,E,W) and also allows mirroring of the screen. These screen views carry forward into all survey and stakeout screens involving graphics.

**View Options**

Graphics | Data | **Display**

Map

South as Reference

### Isolate Points (ISO):

This is another useful command to reduce screen clutter. If you have 500 points on the screen, you can isolate to only those points you wish to see, by entering a distinct point range, in the form 1-10, 22, 25-30, or a certain description. This would isolate to points 1 through 10, point 22 and points 25 to 30, and other points are “frozen”. You can also isolate to descriptions (D for Descriptions) by entering a description such as "EG" for Existing Ground or a wildcard description using an "\*" such as "IP\*" for any description beginning with IP (IP, IPF, IPS, etc.). Repeat the ISO command and enter the full point file range (or “all”) to restore all points.

### Isolate Layer (IL):

Select any polyline layer and isolate it to keep that layer. Other polyline layers are turned off (frozen), but point layers are retained. Use the Layer command to turn layers back on as needed (On All).



### Aperture (AP):

Controls the size of the rectangle area used to select points or polylines from screen. Initially, the size in pixels is 20 units for points selection and 10 units for polylines selection. You can change it as shown. The routine displays the Aperture size dialog.

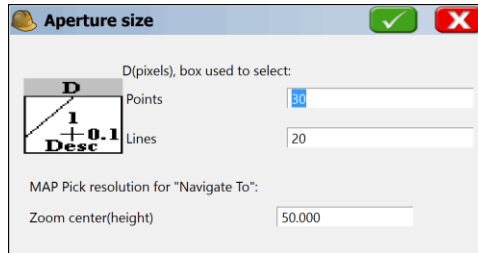

### UCS (UCS) User Coordinate System Indicator:

This toggles the visibility of the UCS icon shown in the MAP screen. This can also be done in the View Options command or through lower left icon in Map screen.



### Find Point (FND):

This command allows you to find a point on the MAP screen. Enter the point you want to find and a zoom height. If you enter a point that is not on the map, the dialog will warn you and allow you to enter another point number.

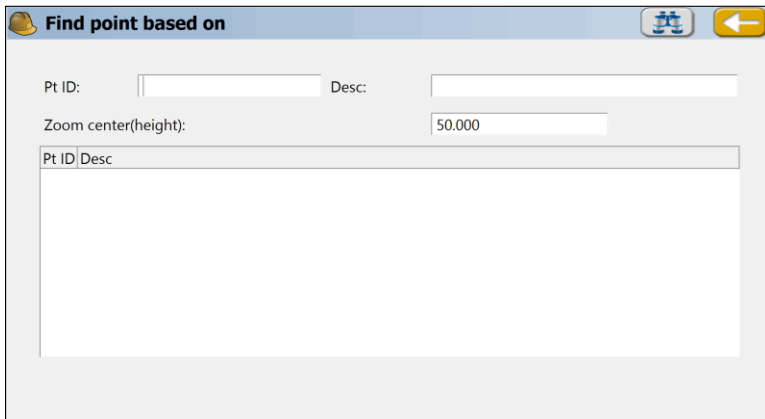

Click Find and the SurvPC zooms to the selected point at the entered scale.



### Scale Bar (SB):

This will toggle the visibility of scale bar on or off. The scale bar is normally shown at the bottom of the MAP screen. The "onTop" option places the icon on top of the Map View saving maximum space for the graphics:

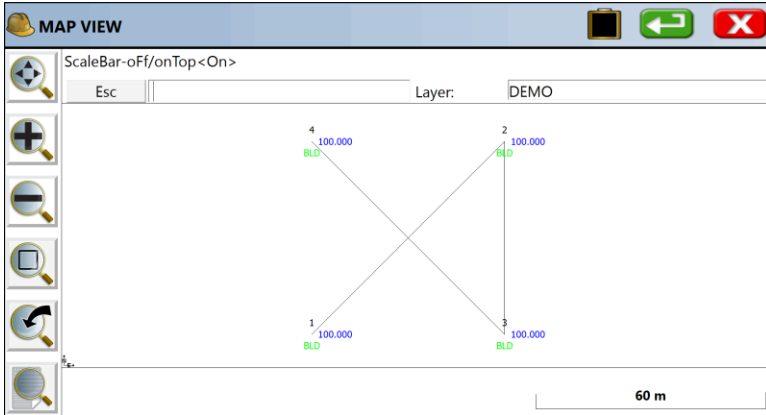

### List Polyline (LI):

Applying to linework entities only, this lists the layer, 2D or 3D status, Closed or Open status, perimeter (length), and area or projected area (if not closed). The coordinates of the polyline are shown including the elevation:

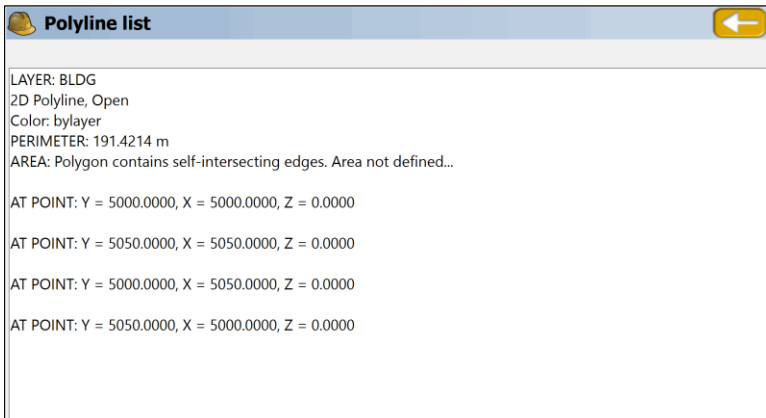



## 9.4 Draw



The Draw menu is found next to the View menu in MAP view. Below you will find each feature described.

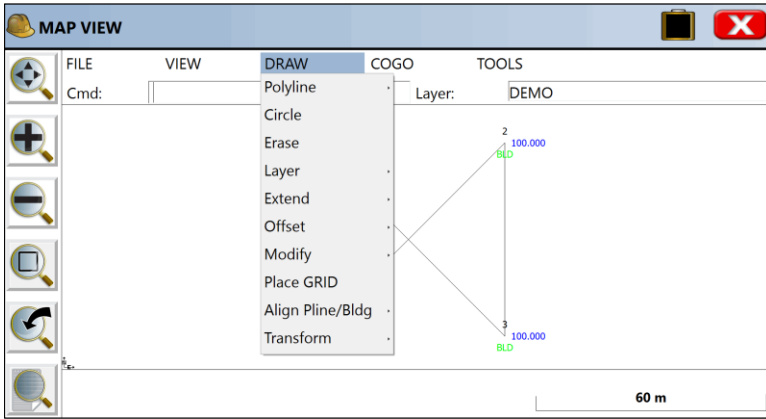

### Draw - Polyline (All options):

This set of commands have been updated for the 6.0 Release with Direction and Distance functionality. Now, when a user initiates one of these commands, the 'Len', or length, option provides the user with options for Direction and Distance of the line to be drawn.

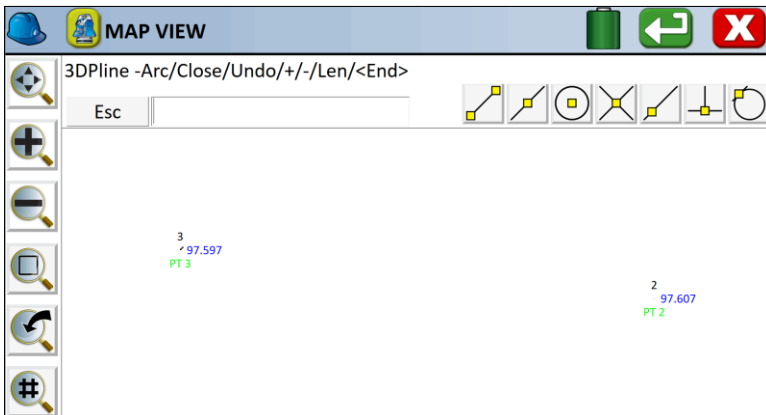





## 2D Polyline (PL) (AutoCAD style):

This command allows you to pick points from the screen or type in point numbers or snap to line segments. The snaps appear as icons (see below) and include, in order, left to right: "Endpoint," "Midpoint," "Center of Arc or Radius Point/Block Insertion," "Intersection," "Nearest," "Perpendicular," and "Tangent to Arc." The "Nearest" snap will simply pick a point on any line or arc you select, at the nearest point to where you pick. First, pick your starting point then you have several options on the command line. You can also draw by point number and even use ranges, as in 8-10,37 which would draw sequentially from 8 through 10 then to 37, as shown below.

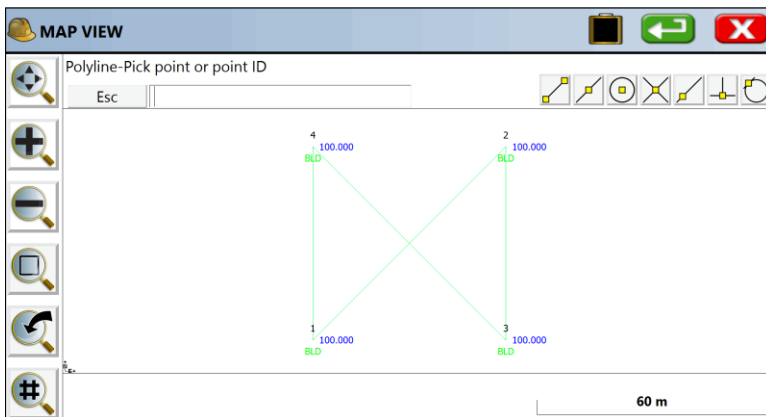

Points can be entered or picked from the screen. The default option is to keep picking points and the other options are described below.

### **Cmd:Polyline-Arc/Close/Undo/<End>**

**A:** Starts an arc segment. See below for details.

**C:** Closes the polyline (you must have at least two polyline segments drawn before you can close)

**U:** Will undo the last segment drawn (you can Undo again and remove multiple segments)

**E:** Will end the Polyline command. Since it is the default, enter will also end the polyline.

**ESC:** This will cancel drawing of the polyline.

### **Constructing an arc segment**

After choosing A, the command line will change to:

Cmd: Polyline-Arc CEn/Len/Sec/<Rad>

You have various options for constructing an arc as part of your polyline.

**CEn:** Allows you to specify the center point (or radius point) for the arc. After picking the center point, you must specify the arc end point and then the arc direction.

**LEn:** Allows you to specify the arc length. First you pick the arc end point and then you can enter the arc length. The minimum arc length is given to you.

**SEc:** Allows you to specify the second point and end point to define the arc.



**Rad:** Allows you to specify a radius length. First you pick the arc end point and then you can enter the radius length. The minimum radius length is given to you.

### 2D Polyline (Road):

This command allows you to draw a 2D Polyline. You can draw by point number, with ranges as in 8-12, or by picking on the screen using snaps or picked points. This command is similar to the polyline command described above with the following additions:

**+/-:** The +/- options activate an additional prompt that allows you to plot line segments at a 90-degree deflection angle from the last line. [+] is a right deflection and [-] is a left deflection.

**Len:** This option prompts you for the length of a line segment. Enter the length and a line segment will be drawn that length using the same bearing as the previous line segment. If the previous segment is an arc, then the new segment will be tangent to that arc.

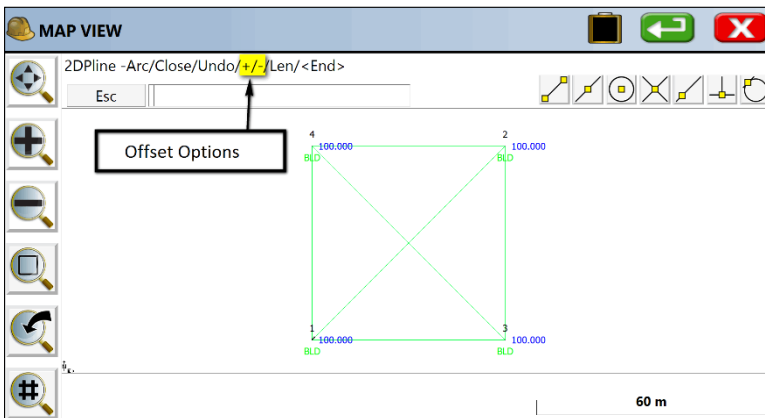

### 3D Polyline (3DP):

The 3D Polyline command is similar to the 2D polyline command. It will even draw arcs but will create a polyline on the screen with many vertices at different Z elevations which are linearly interpolated around the arc. If the start of the arc is point 17 at elevation 842.246 and the end of the arc is point 9 at elevation 839, then using View, List, you would see intermediate vertices (note that the segment length between vertices is about 0.12 units in this case).

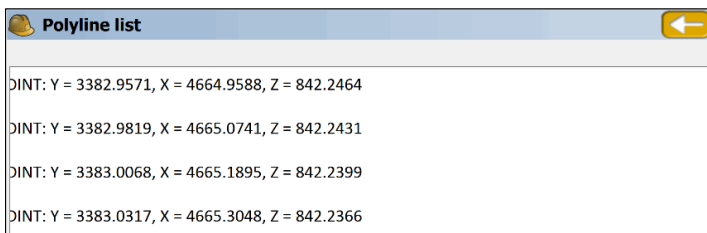



Using the snaps to draw lines can accomplish advanced coordinate geometry calculations. For example, if you offset two polylines and wanted to determine the point where the offset lines intersect as well as the corner of the driveway, you could draw a line from intersect to endpoint and do the command PolyLines to Points (COGO, Create Points), which would create points 50 and 51. PolyLines to Points will not find intersects, so it is more direct to simply do Draw Locate Points and use the intersect snap to create point 50 (COGO, Create Points). These procedures avoid complicated COGO involving curve-line intersects at offset. If your goal is to stake out points, you do not even need to create Point IDs, since the command Stake Points will locate points by snap, directly from the drawing.

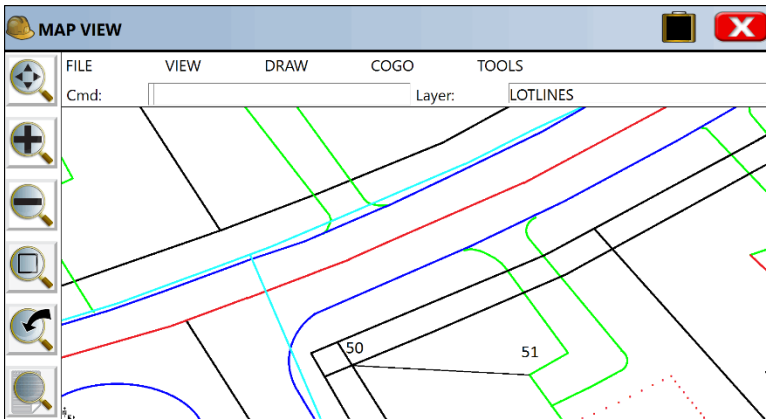

### **Circle (CR):**

This command draws a circle entity, based on diameter defined by two points or based on a center point and a radius. You can select and erase the circle with the command E for Erase. The circle is considered a polyline.

### **Erase (E):**

Erases all selected polylines. It will not erase points. Note that you can erase an entire area by selecting a Window through the polylines (picking first a lower left point in “blank space”, then picking an upper right point). If you even contact or enclose any polylines with this window selection, they will be erased. So the “window” erase procedure mimics the “crossing” selection method of AutoCAD (r). If you enter "All" at the Cmd prompt, you will erase all linework. There is no Undo, so this would be permanent for that Job. However, you can redraw any linework created by Feature Codes, using MAP, Tools, Field to Finish.



### Delete Layer (DL):

Select from a list one or more layers, or select "From Screen", then the routine will delete all the polylines on those layers. If you entered C\* at the lower line, the entities on all layers starting with the letter C would be erased.

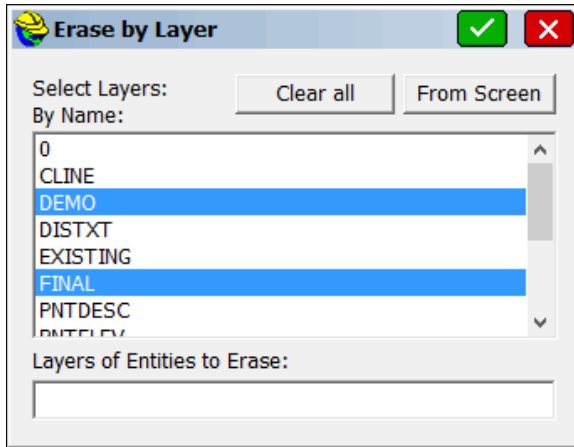

### Change Layer (CHG):

This changes the layer of the selected polylines. One form of selection is to type L and press Enter in order to select last created polyline from the drawing. The routine displays the "Change entities to layer" dialog box. When the dialog appears on the screen, the selection in the layer list will be set to the current layer. Pick another layer to change layer. Clicking the color bar (where it shows "bylayer") brings up the color palette, letting you change the color by picking or ByLayer. So you can change the layer of a selected polyline or you can keep its layer and just change its color.

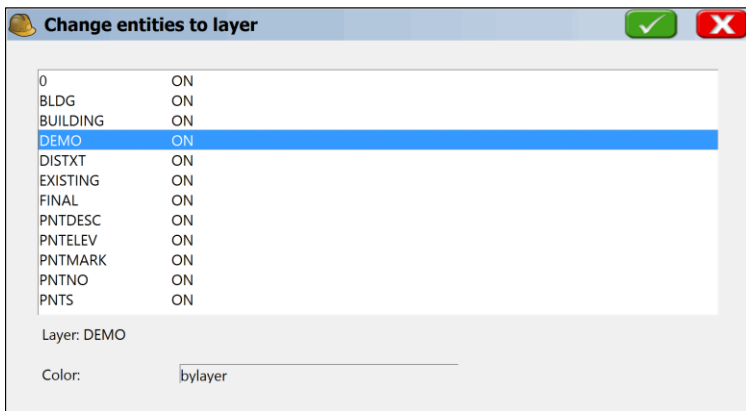



**Extend - By Edge (XBYEDGE):** First select the line to extend to, then the line you wish to lengthen and extend. In the example below, pick the line at left first, then the short line to extend second, and you obtain the result. There is a U for Undo option if you do not want to keep the extended line.

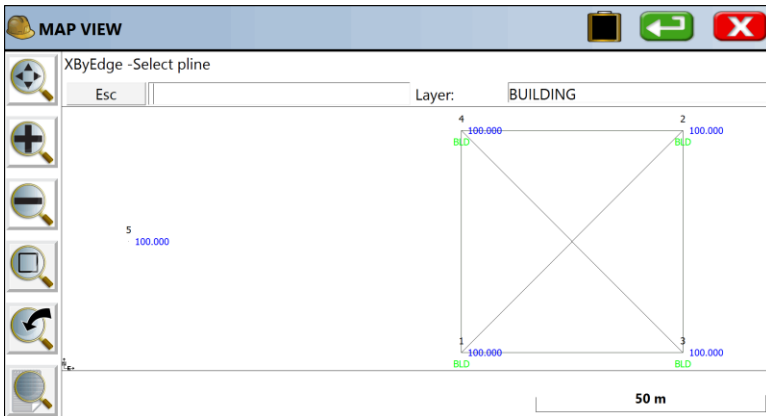
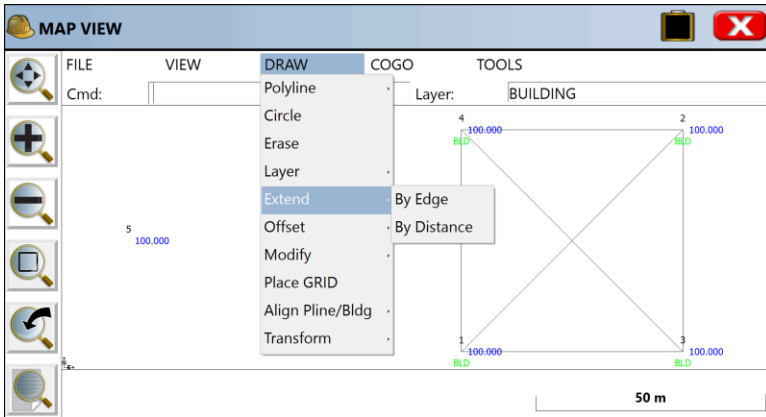

**Extend - By Distance (XBYDIST):** This powerful command allows you to create figures such as buildings, walls and other linear features that can then be staked out or used simply as a graphical reference or for additional CAD operations like offsets. If the distance from 99 to 100 is 7.07 feet, and you wish to make an L-shaped building that continues past point 100 for a total distance of 10 feet then goes 15' right, 20' right, 10' right, 10' right and closes, this is done with the following entries:



**XBYDisT-Last/Points/<Select Polyline>:** Press Enter to Select a Polyline and then pick, towards point 100, the starting line segment. The arrow will appear towards the picked end. If you get Point Details, you have not pressed Enter to "Select Polyline".

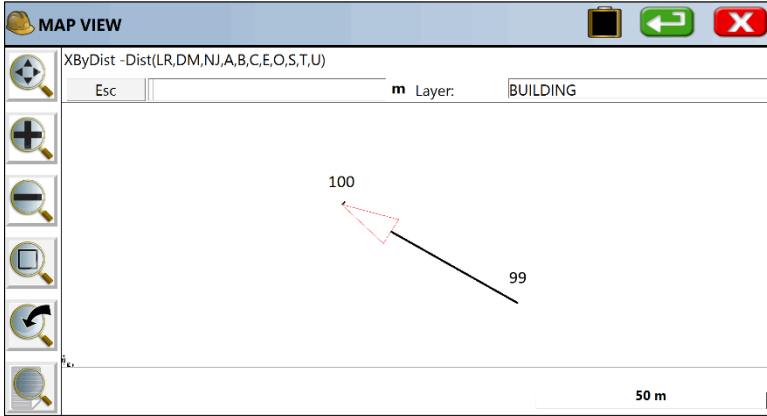

Then enter T for Total Distance (program displays current distance of 7.07), then 10 (the additional 2.93 feet is drawn), then R for Right. The arrow then turns to the right. Then enter 15 then R, then 20, R, 10, R, 10, then C to close.

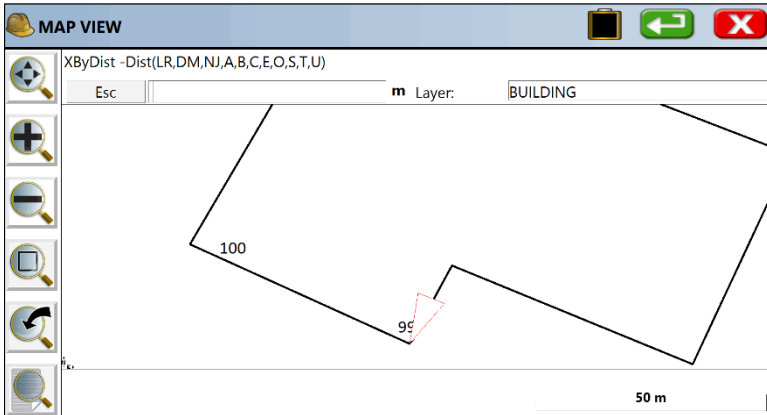



The full list of options are:

Abbrev.	Command	Description
L / R	Left / Right	Two L's or two R's would reverse the direction of the line
M	Move	Moves without drawing. Acts like a 'pen up'. You can then enter left and right distances
D	Draw	Draws after a Move. Acts like a 'pen down' Distances entered will draw.
N	Number	Creates point numbers at the vertices and numbers from the end of the job file.
J	Jog	Turns off point numbering and goes back to simple 'jobs' of line segments. This is the default condition.
A	Arc	Draws arcs based on radius point and end point or radius length and end point.
B	Bearing	(-aZi / Brg / ToPoint / <Ang>) Entering 45 turns an angle of 45 degrees. B for Bearing allows bearing entry in all modes accepted by SurvPC, such as N34.15E. you can also draw by azimuth or to a point ID.
C	Close	Used in the example above to close to point 99, the starting point.
E	Extend	Will extend the line to any selected polyline.
O	New Polyline	Starts a new polyline and creates a separate entity, even though the figure will appear continuous.
T	Total Distance	Total Distance
U	Undo	Undo
Esc	Esc	Will exit the command at any point.

### Offset Settings (OF):

This command allows you to set the type of corner that SurvPC should create when offsetting entities.

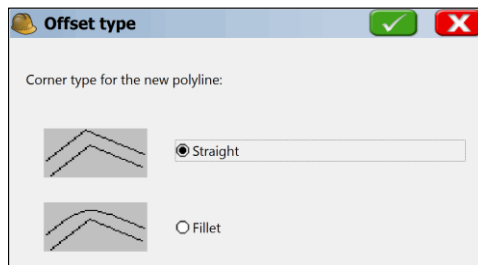



### Offset - 2D (O2):

Mimics the AutoCAD (r) Offset command, and only works with 2D polylines. Enter the offset distance and pick the left or right offset amount. The building pad at left in the graphic associated with Segment Offset was offset 10 units in the outer direction, for example. The 2D and 3D offset commands have the option to fillet the corner (create arcs of radius equal to the offset distance) on exterior offsets based on Offset Settings under the Tools pulldown menu. This exterior offset with arc is sometimes referred to as a "buffer" offset, in that all points on the exterior offset are exactly the same distance from the source polyline. Buffer offsets are sometimes used for easements or GIS applications. Offsets to the interior will not create arc segments.

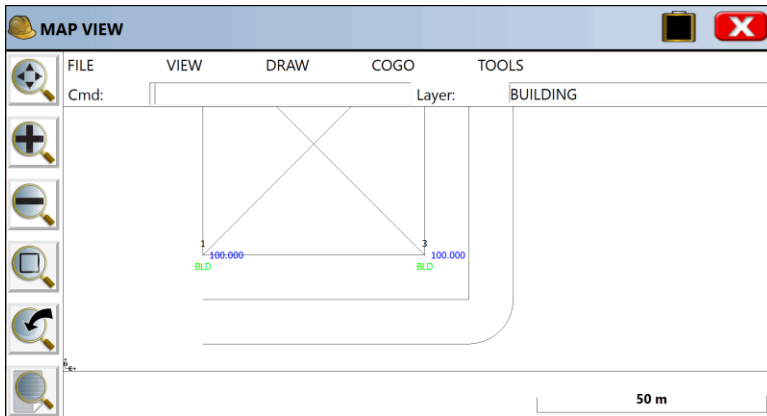





### Offset - 3D (O3):

This command offsets 3D polylines both horizontally and vertically. It is great in combination with road/utility centerlines to create offset polylines to stake. It can be used for ditch lines, curbs, walls and many other applications. The standard offset method is "Interval". In the case below, a 3D polyline for edge-of-pavement (EP) was offset Horizontally 0.2 then Vertically 0.5 for top of curb, then offset again 4.5H and 0V for outer edge of sidewalk. These three 3D polylines can then be selected in Stake Road, option "Cut from Alignments" and then with the outer sidewalk edge selected as the "centerline", the stakeout screen would appear as shown below (exaggeration 4x):

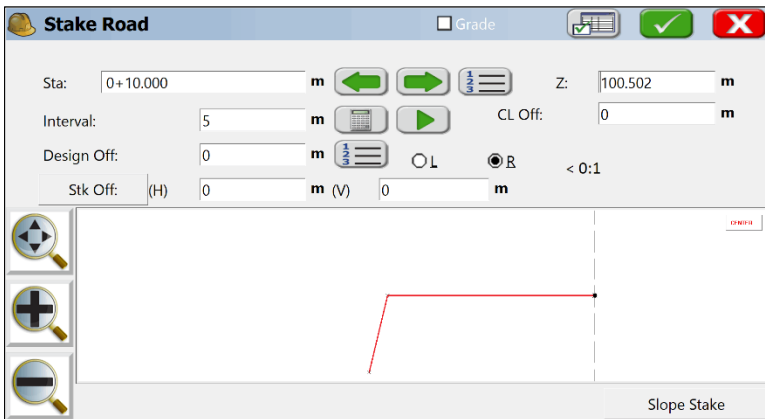
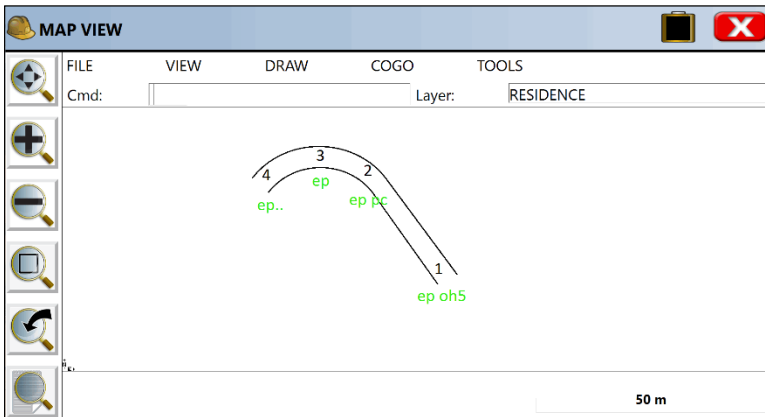

Using the "Interval" method (normal method), vertical offsets can be by elevation difference (default), or by slope percent or ratio. The default "Continuous" option keeps the offset 3D Polyline as a single entity. If you do the "Segment" option approach, only the segments of the 3D polyline will offset (leaving gaps), and you have the option to create Point IDs on the offset vertices.

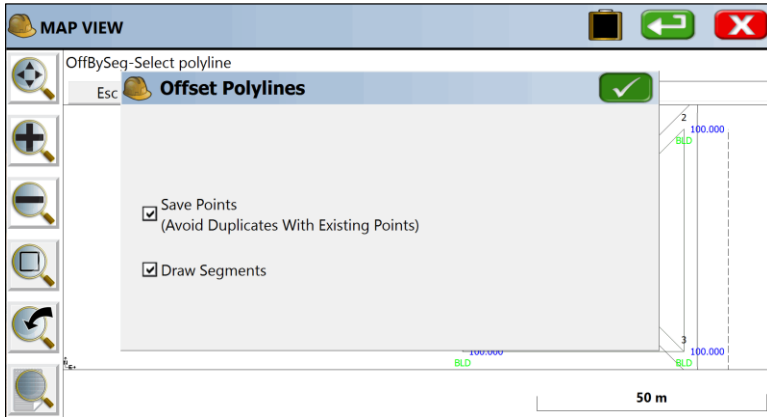

The "Constant" option takes a 3D polyline and offsets it to a constant elevation for all vertices. So if you measured the base of a retaining wall that sloped downhill, but the top of the wall was a constant elevation, you could offset a fixed horizontal distance to that single elevation.

### Offset - By Segment (OSEG):

This will offset all vertices of each segment of the polyline in a 90-degree offset and will draw line segments or optionally create points at the offsets. This is shown at right (in contrast to the parallel line offset at left) in the graphic below. You begin by entering the offset amount (e.g. 10). Then a dialog appears with options to Avoid Duplicates and "Draw Segments", which, if unchecked, removes the line segments and leaves only the points.

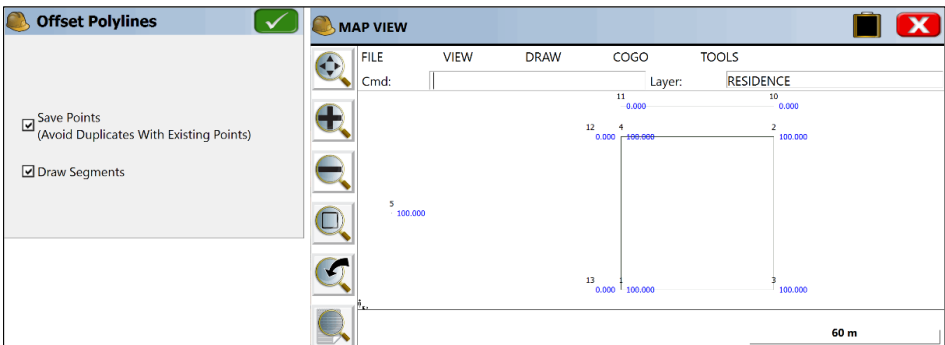

For L-shaped buildings or figures with angles, an additional interior offset point is calculated at the intersect of the parallel lines based on the entered offset distance, such as 10 (see point 165 below--the lines to 165 are drawn only to illustrate the 10' offset):

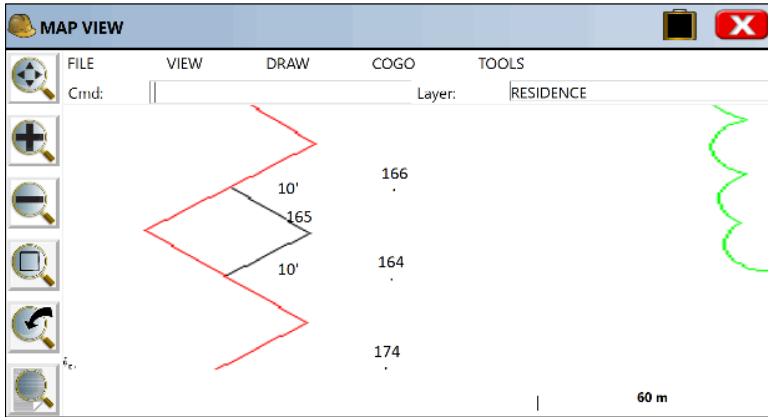

For L-shaped figures, offsets are also projected through to the other side, so that the offset for point 174 appears across the building, for purposes of pulling a stringline.



### Offset - Buffer Offset (Offsetb):

Pick any closed figure or multi-sided figure and you can offset, typically to the outside, using a rounded radius corner, such that all points on the offset line have the same distance from the nearest point on the figure. An offset of 2 units was used below on the closed polyline shown, using Buffer Offset.

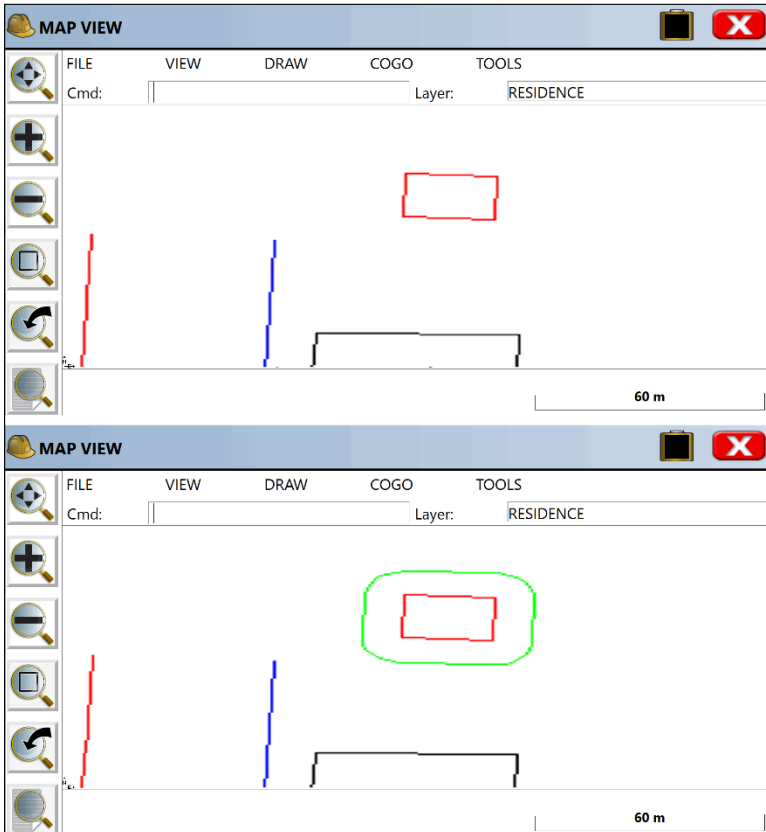



### Offset - 4-Sided Building (DrawBldg):

Sometimes it is possible only to measure 3 points on a rectangular building. If you connect the 2 sides with a 3-point polyline, you can click on the building using the command Offset, 4 Sided Building, and create the missing 2 sides.

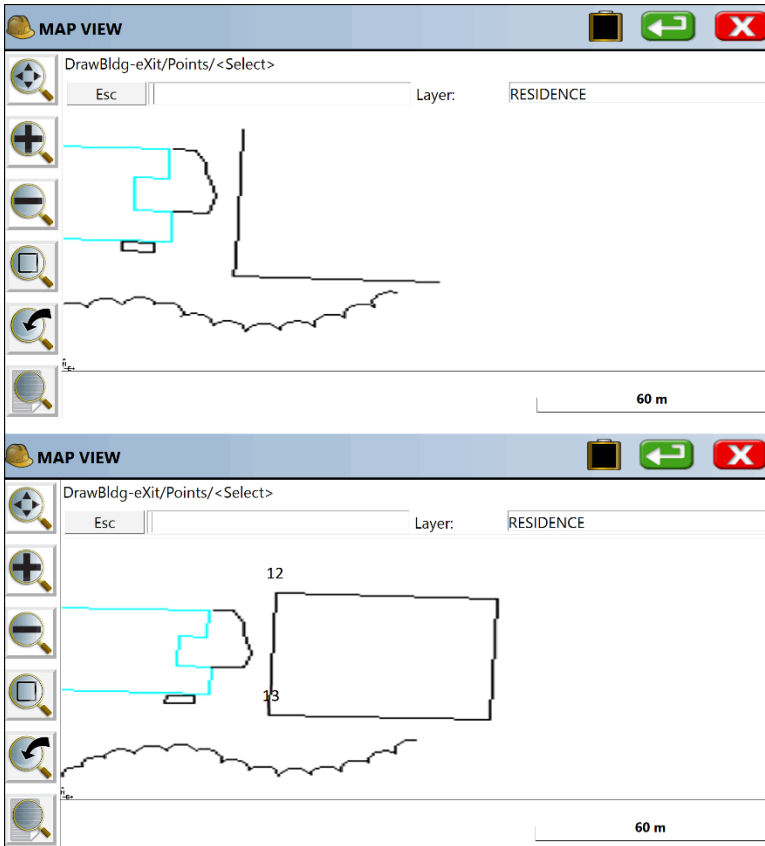

You can select by tapping the building or choose "Points" to enter point 12, 13 and snap the endpoint of the 3rd side, for example. If you have only measured 2 points for a rectangular object, the command will still work--it will prompt for the offset distance (positive is to the right, negative is to the left) and create the 4-sided building or object. You will get a warning if a picked polyline has more than 3 vertices--in that scenario, use the "Points" object to pick the 3 corners of the building.



### Modify - Remove Arcs (RMA):

Pick any polyline with an arc, specify the “offset cutoff” spacing, and turn the arc into chords. Offset cutoff refers to the maximum separation between the chord and the original arc. If you enter a small cutoff distance of 0.1, then at no point do the chord segments differ from the arc than 0.1. Be careful with this command – there is no “Undo” to restore the arcs (though you can immediately start a new job and “re-load” the last, saved DXF file of the drawing). After removing arcs, you can draw a polyline from points on the arc, after creating small chords, using the "endpoint" snap (first snap on the left in the list of snaps).

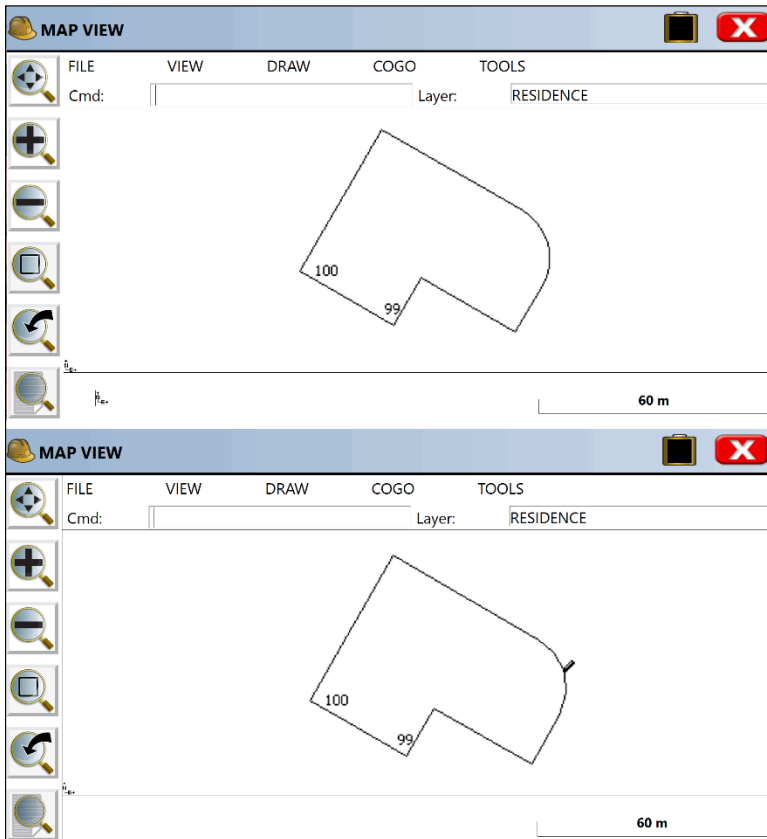



### Modify - Fillet (F):

Similar to AutoCAD's Fillet command. It prompts: Cmd: Fillet -Ra/PI/eXit/First seg 25.00. If you are trying to inscribe a curve at the corner of a polyline, you enter the desired radius first by selecting R for Radius (at the above prompt). Then you choose the P option. This leads to the prompt, Cmd: Fillet -Ra/PI/eXit/Select pl 25.00. Select the polyline near the vertex where you want the curve to go. This completes the process. If you wish to change the radius, enter R. If you want to fillet the corner of 2 distinct polylines, then just pick them as prompted (do not do the P for Polyline option). This command will only work with 2D polylines, completed with the command 2DP, or imported from a DXF file as 2D polylines, or converted from 3D using the command C2D which changes the vertex elevations to zero.

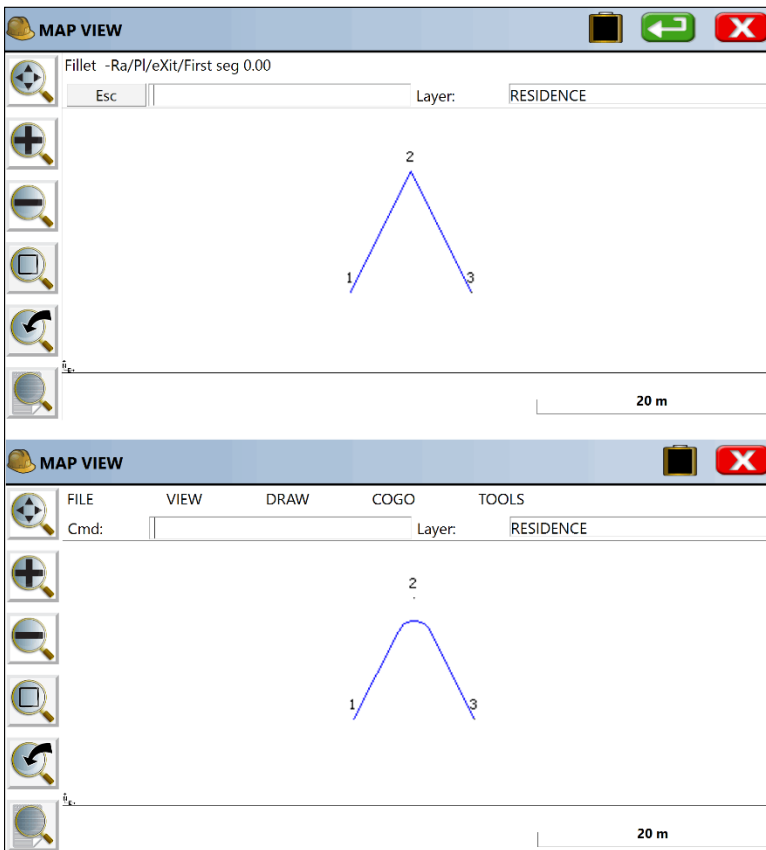

See the above two figures. Because in the Left figure, from 1 to 2 to 3 was one continuous polyline, after the radius was set at 15, P was entered to set up the one-pick approach for polylines, leading to the completed fillet command and the result as shown in the Right figure. Now you can do Cogo, Interpolate Points, Polylines to Points (P2P) and solve for the points for the beginning of the arc, radius and end of arc, for purposes of stakeout (set out).



## Modify - Join (JN):

This command allows you to join polylines. Enter D to specify a new maximum separation distance, then select the polylines on the MAP screen. If you use 0 for Distance, then the polyline to join must be separate polylines connecting to common points. The advantage of joining polylines is that they can then be offset as a unit, and the vertices of the offset polylines can be turned into points for stake out. The offset command, in effect, does all the complicated bearing-bearing intersects for you. For example, if the resulting polyline were a pipeline with a 20-meter total right-of-way, then to stake the right-of-way points, you would offset the polyline 10 units left, then 10 units right, then turn both offset polylines into points, or directly stake by snapping to the offset polylines using endpoint and nearest snaps.

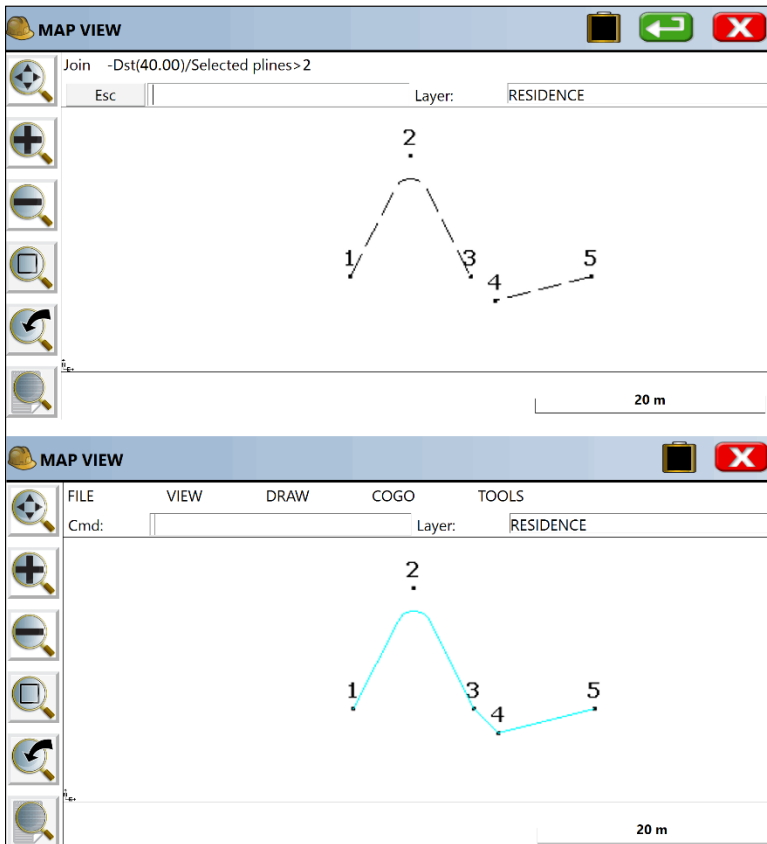





### Modify - Trim (TM):

This allows you to trim polylines to the edge of other polylines just like in AutoCAD (r). Then the command Polyline to Points (P2P) will turn all vertices, including the trimmed end points, into points for stakeout.

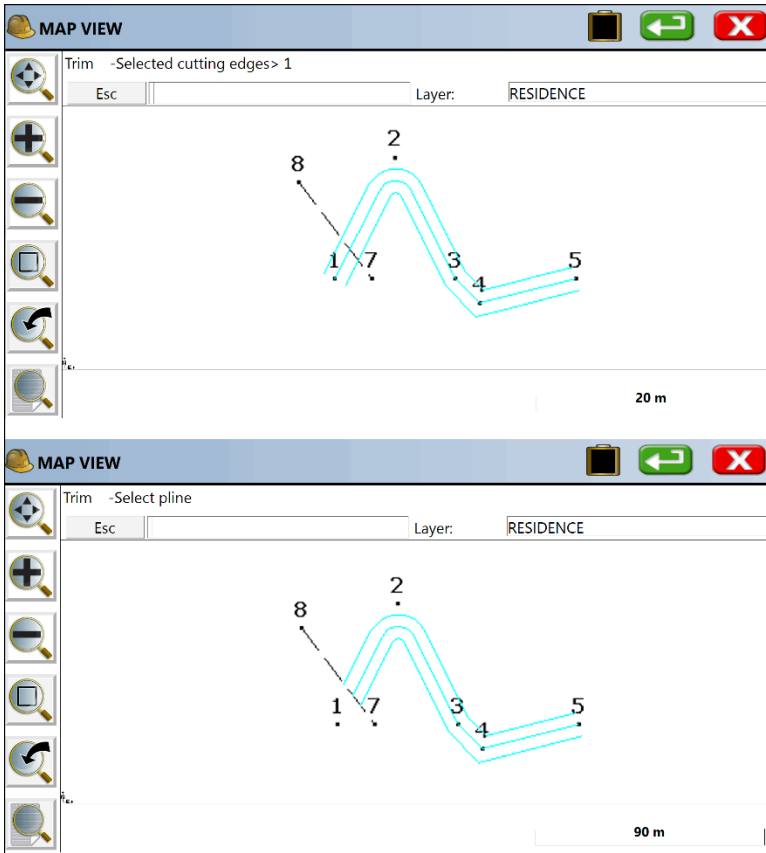



### Modify - Reverse Polyline (RV):

When you turn a polyline into points, it will start the point numbering at the beginning of the polyline. Thus, it may be useful to control the direction of the polylines for purposes of stationing and staking. This is done with the command Reverse Polyline. Each time you pick a polyline using this command, you reverse its direction, and little temporary arrows are displayed along the polyline indicating the current direction. If it is not the direction you want, reverse again.

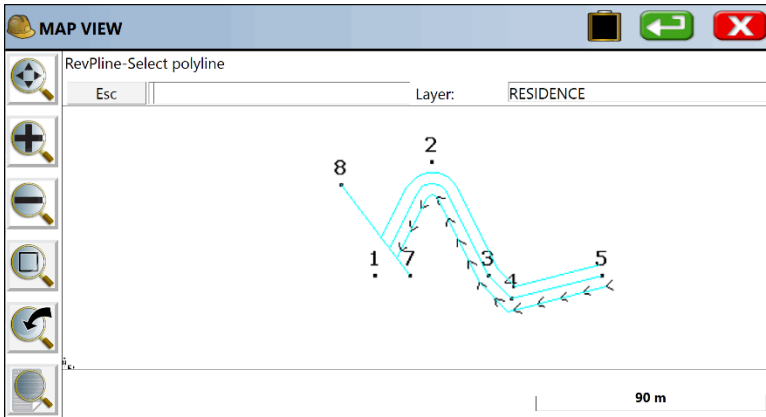

This command is useful to prepare for Stake Road using Cut from Alignments. The polylines for the various road breaks in grade need to be drawn in the same direction for "Cut from Alignments" (screen selection of 3D polylines) to work effectively. So, in the instance below, if the alignment goes south to north (point 14 to point 15) and the ditchline polyline shown is drawn in the wrong direction, use Reverse Polyline to get its direction matching that of the main centerline. In this case, pick it one more time to reverse it so it goes south to north.

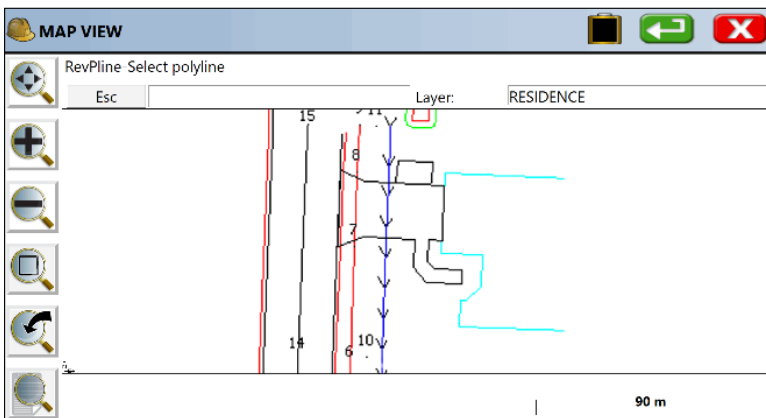



### Place (Draw) GRID (DG):

This command toggles a horizontal and vertical grid display over your drawing, allowing you to set the grid resolution in drawing units. These grid lines are for reference only and are not part of the stored drawing associated with the job. To turn off, repeat the command and enter Off.

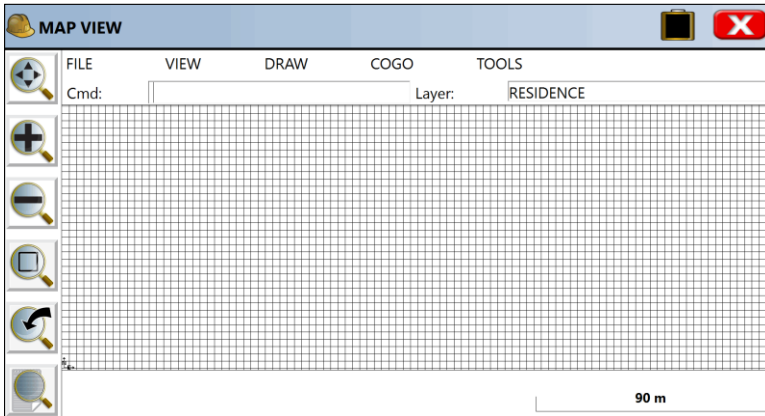

### Align Settings (ABSET):

This command allows you to select between two methods of aligning buildings using the Align Building One Segment command under Draw, Align Pline/Building. The first method (offset-distance) aligns buildings parallel to the sideline based on a sideline offset and a distance offset along the sideline to the front of the building. The second method (offset-offset) holds the building parallel to the sideline but ensures that the frontage offset to the selected corner of the building matches the second offset value.

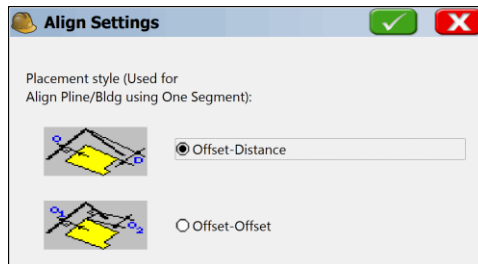



### Align Pline/Building One Segment (AlignB), Offset-Distance Method:

This is a building application allowing adjustment of the building pad location in the field. If you import a map of a subdivision or building project containing a building pad, side lot lines and a frontage line, you can reset the building pad to a new, specific offset from the frontage and also force the building pad to be parallel to a selected side lot line, at a specific offset to the lot line. Refer first to the graphic below which shows an existing building on lot 84. Using the I for Inverse command in the MAP screen, you can obtain the distance from the end point of the building and then select the perpendicular snap on the lot line. The distance is 18.7 feet. Similarly, the distance from the building to the arc of the frontage line can be computed at approximately 58 feet.

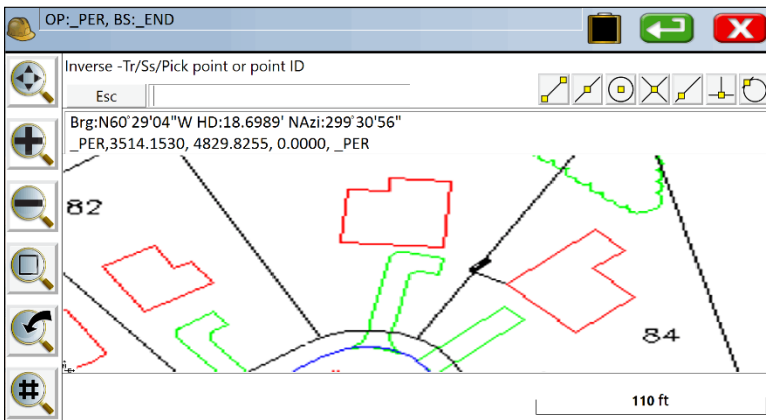

There are 2 methods of Building Align, which are set under Tools, Align Settings. The first method is to align the building parallel to a lot line at a certain offset from the frontage, measured along the lot line. This is the Offset-Distance setting for Building Align. To illustrate this method, assume the goal is to place the building parallel to the side lot line at 20 feet offset, and offset from the frontage at 65 feet as measured along the lot line. Here are the prompts for the Align Building command:



**Pick Lot Segment Near Front Corner (of lot line):** Pick the line shown below near where it contacts the right-of-way, near the front. The building setback offset will be calculated from the front end of the lot line.

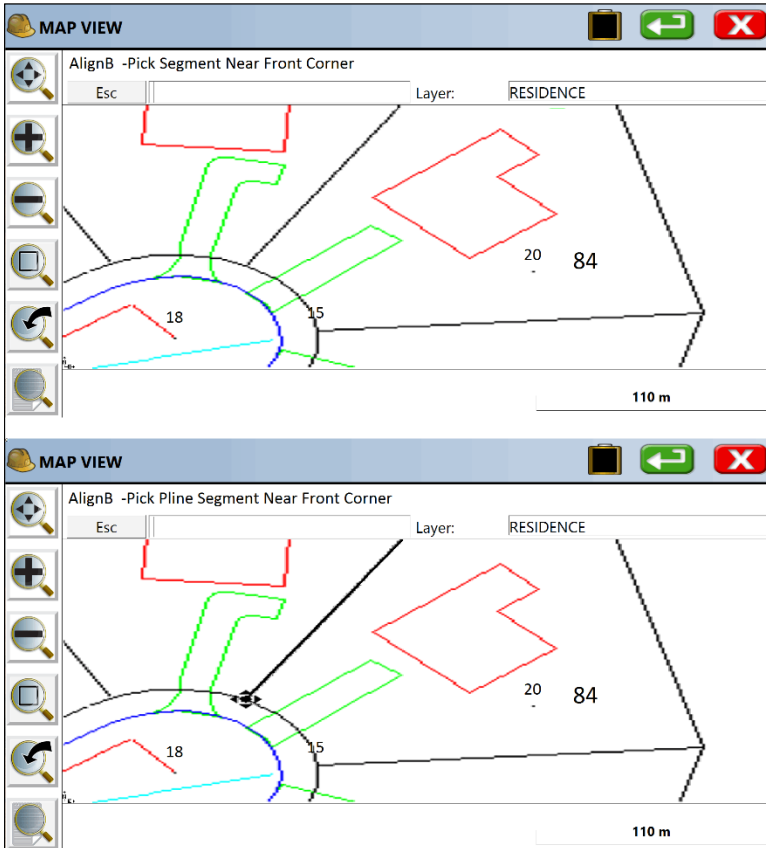



**Pick Pline (Building) Segment Near Front, Lot Side:** Pick the same lower left building corner as shown above, but along the side facing the adjoining lot line. This leads to the graphic below. The correct side line is highlighted.

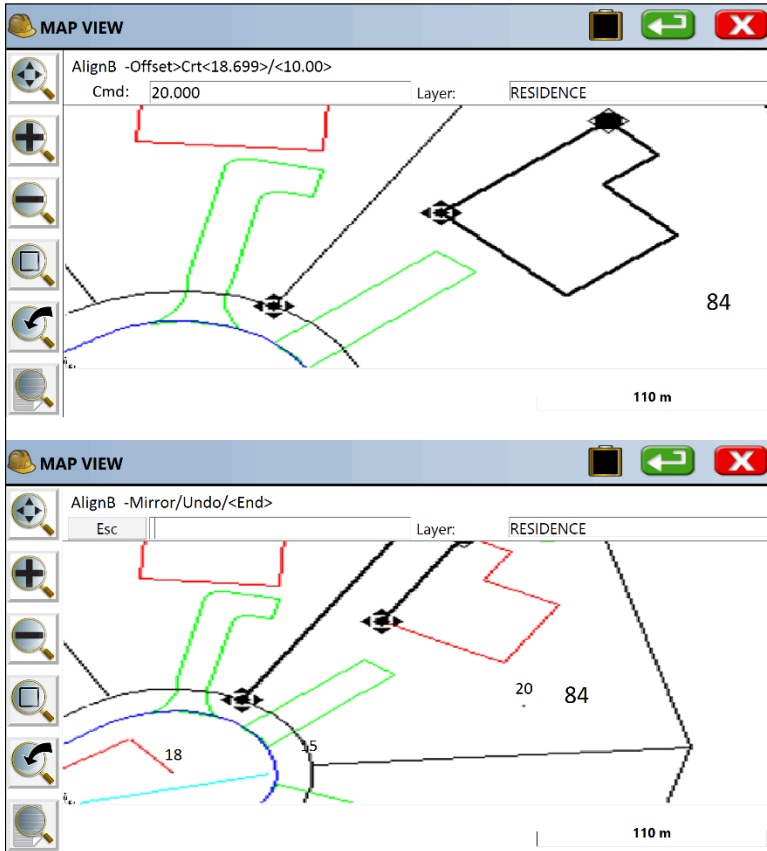

**Offset>Crt<18.699>/<10.000>:** Enter the desired side line offset (20).

**Distance>Crd<57.919>/<10.000>:** Enter the desired frontage offset (65), as measured along the selected side line. The building redraws as shown. You can Undo or enter M for Mirror, which mirrors the building around the highlighted building line (and in this case would force the building across the lot line). Even after you experiment with Mirror, you can Mirror again or Undo the entire process.



**Align Pline/Building One Segment (AlignB), Offset-Offset Method:** If the Align Settings under Tools is set to Offset-Offset, then two offsets will apply using the One Segment command: (1) to the side line and (2) to the front line. This method requires that the lot line be a continuous polyline for both the side and front portions of the lot, allowing just one pick, hence "One Segment" method. Also, both lines need to be straight--this option will not handle a curving front line. It is best illustrated in the simple example below:

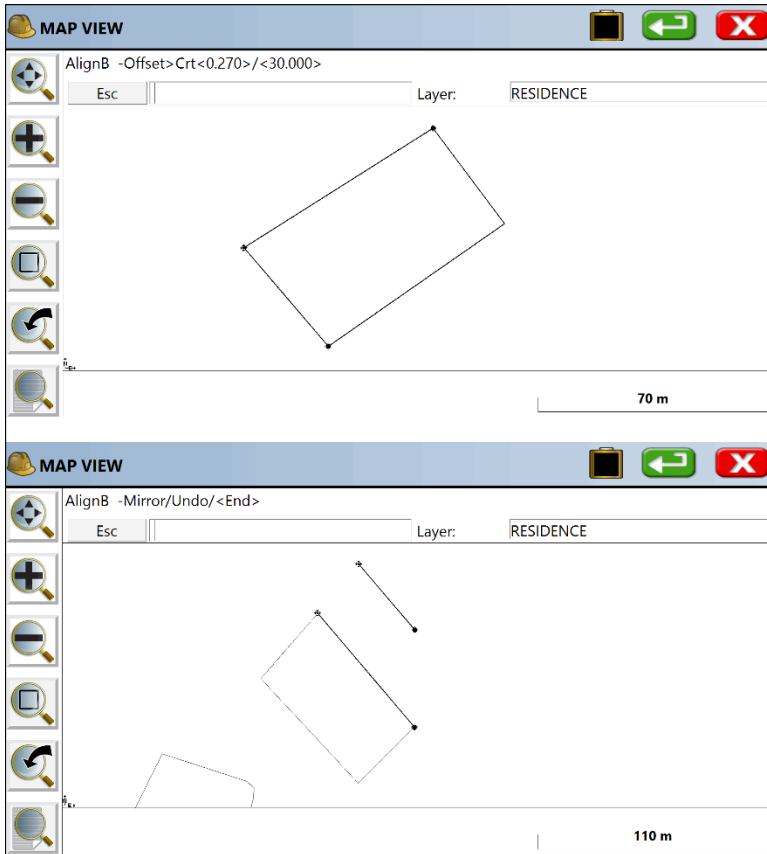

**Pick Lot Segment Near Front Corner (of lot line):** Do the same pick as before on the side lot line opposite the building, near the frontage portion of the lot line.

**Pick Pline (Building) Segment Near Front, Lot Side:** Then pick the building also on the side facing the side lot line, between points 9 and 10 but closer to point 10. Then enter the side offset first (30 in this case) and then enter the frontage setback offset next (50 in this case). This results in the new position for the building as shown, 50 units from the frontage line and 30 units offset from the side line, ready for stakeout. Stake



out the new building by snapping to the endpoints in the command Stake Points or follow with Offset by Segment to stake offset points.

### **Align Pline/Building Two Segment (AlignBC):**

This option is almost identical to Align Building One Segment, Offset-Offset method covered immediately above. The only difference is that the frontage line can be a separate line, allowing for 2 picks to identify the side line first and the frontage line second. And similarly, both side line and frontage line must be straight. The command does not handle arc segments. The command differs from the Offset-Offset, One Segment method only by asking for separate picks for the side lot line (first) and the frontage lot line (second), as shown below. In fact, you can pick a continuous lot line in 2 picks, so it works with continuous or distinct, separate lot lines identically. For this reason, it is recommended just to keep the Align Building setting on Offset-Distance and use the 2-pick approach for the double offset method.

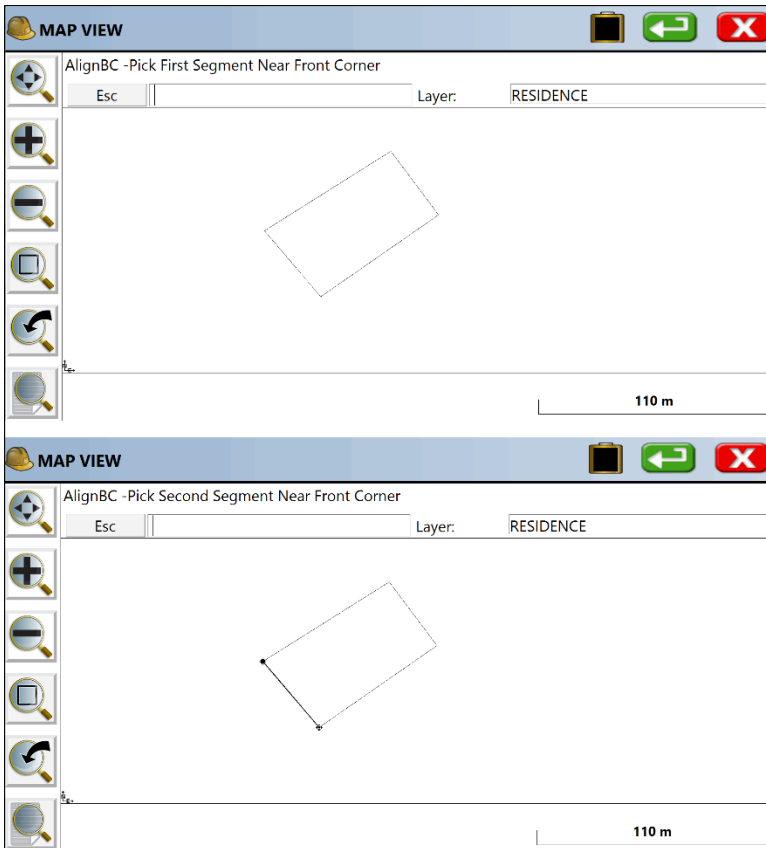





### Transform (MOV, ROT, COP, SCL, MIR):

This command allows you to reposition polylines in the drawing to new locations based on your point geometry. The transformation options are Move, Rotate, Copy, Scale, Mirror. These work much like they do in AutoCAD, with input being the base or source point, and the destination or target point, rotation or scale. In the case of Rotate, the base point is the rotation pivot point and then you enter a rotation angle.

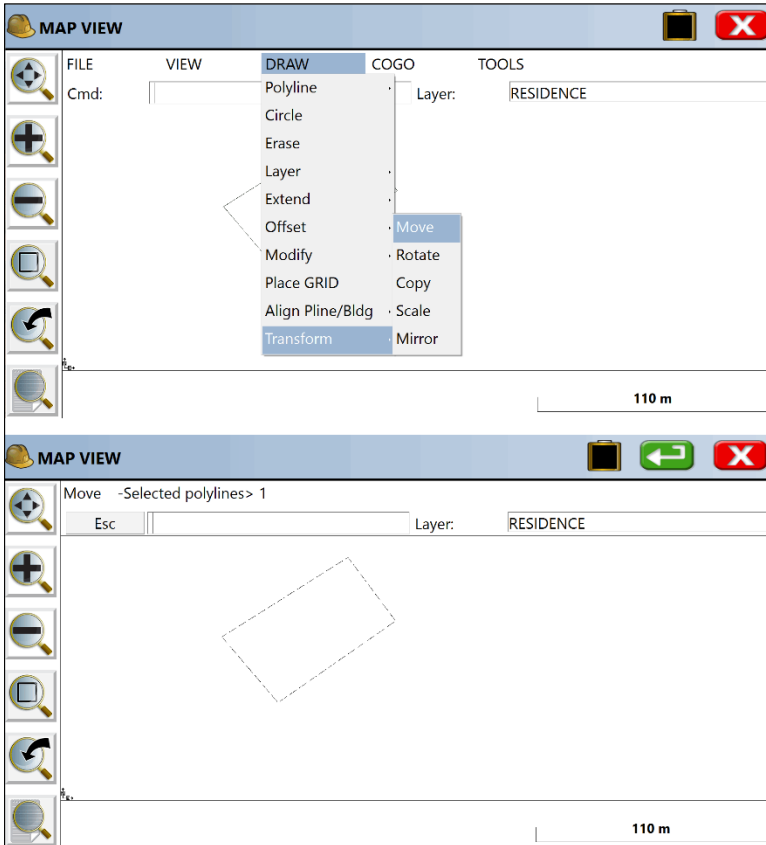



The **Move** command is shown above. One or more polylines can be selected. Then the move must be defined as the relative distance between two selected positions. If the first "Source Point" is point 10 (entered as 10) and the second "Target" position is the right corner of the selected polyline (snap to endpoint), the end result would be as shown below:

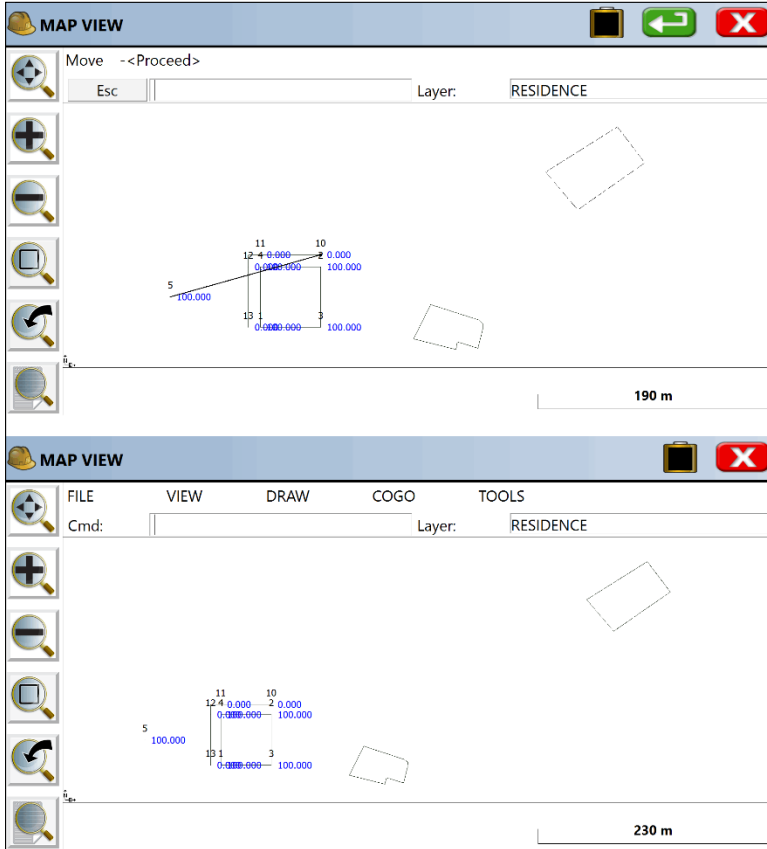

The polylines can be returned to their original position by just reversing the order of the selected Source Point and Target Point. The Copy command may also be used as a Move command, since it has the advantage of showing the new copy and keeping the original, in case you wish to erase the new version and repeat for better results. The Mirror command includes the option to delete the source or retain the source entities.

*Note: These commands only move selected linework and do NOT reposition the corresponding points in the drawing.*



The **Rotate** command has the following prompting:

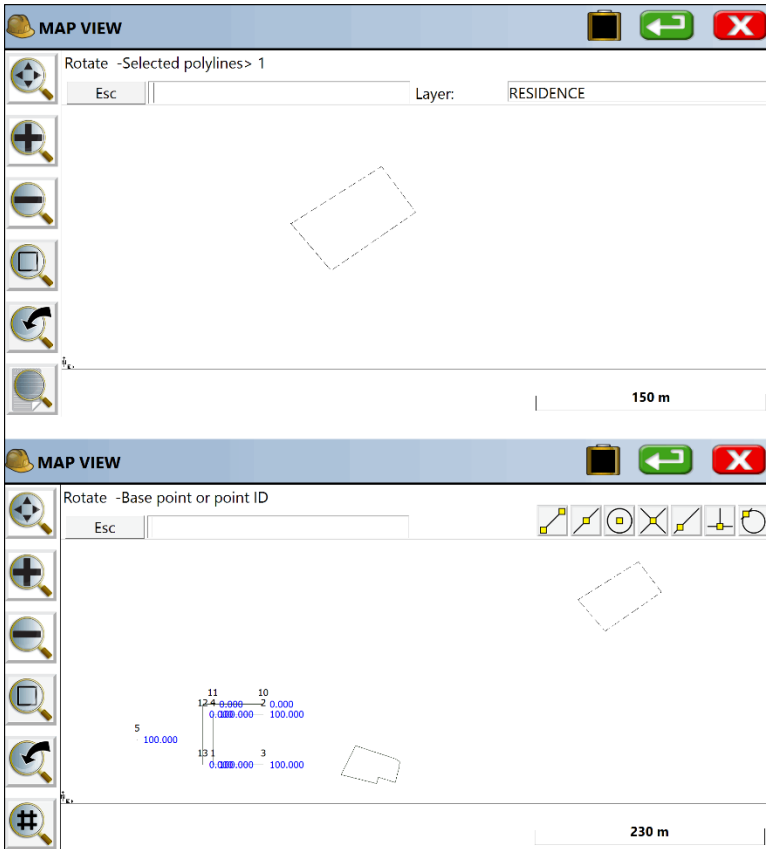

First you select the polylines to rotate. Press Enter when there are no more selections. Then choose your Base Point for rotation.



Here, we use the Endpoint snap and select the corner of the building shown.

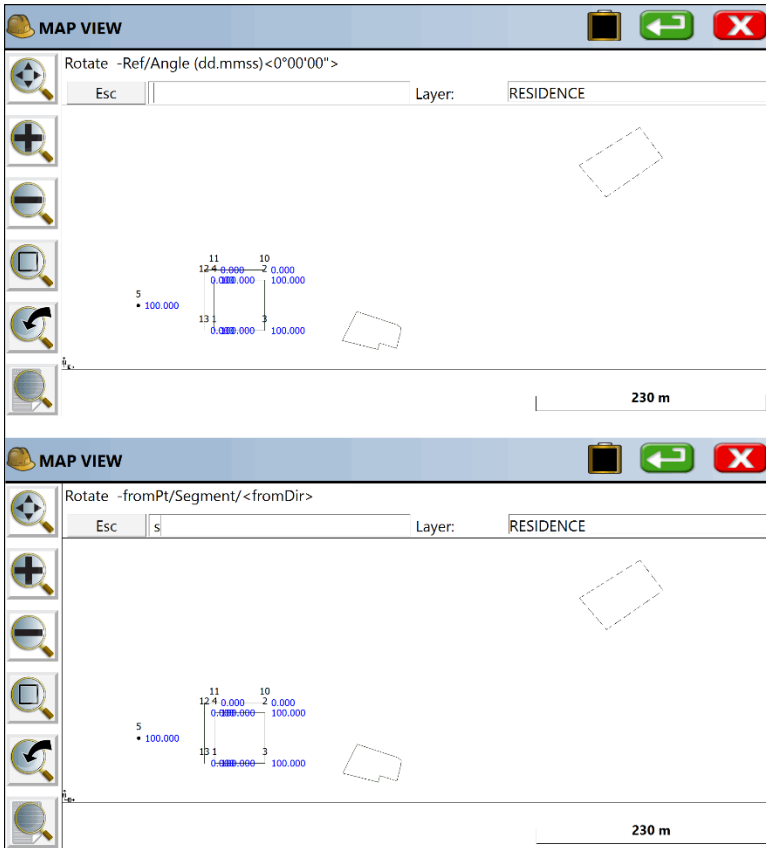

Select the pivot point first. If you want to make it parallel to an existing line, choose R then S for Segment, then pick the segment on the figure you wish to reference first. Then after that, the next pick, also by S for Segment, will be for the property line (e.g. the line to the north) you wish to match.

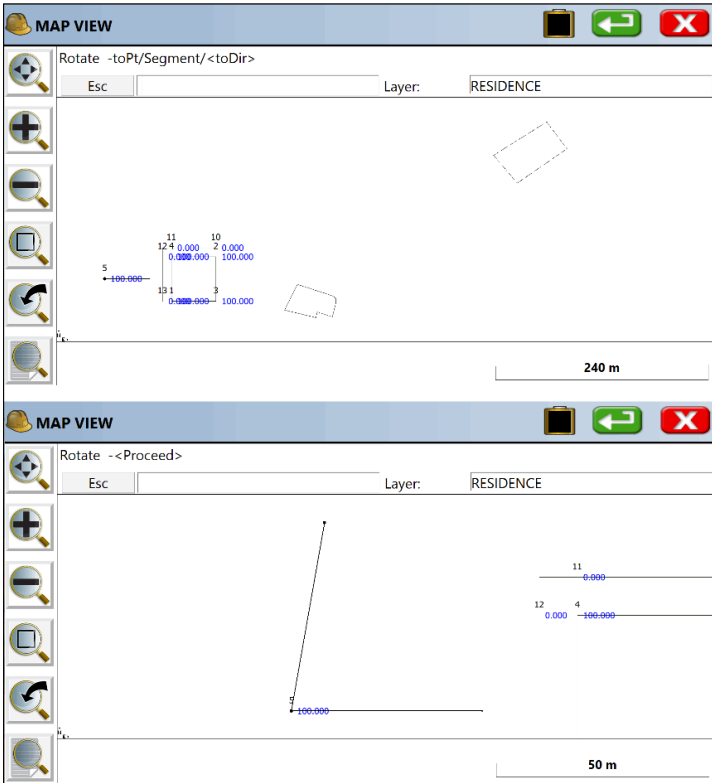

After the rotation is confirmed, you obtain the final results shown below. The simplest rotation, of course, is just by angle, where 10 degrees would rotate 10 degrees clockwise from the pivot point.

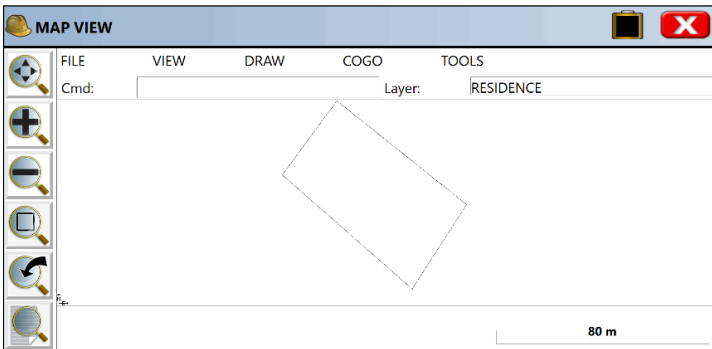



The **Scale** command operates much like the others by first requesting a base point for scaling, and then a scale factor: R for Ref is similar to rotate, where you specify the segment on the object that you are referencing and then the segment on another object you wish to match, for scaling.

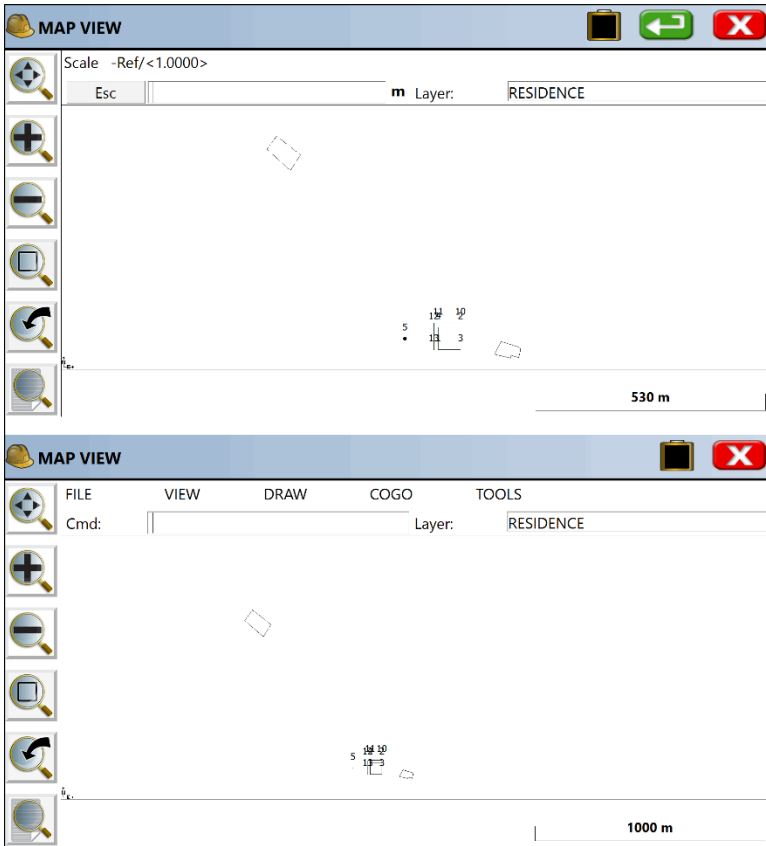



## 9.5 Cogo



The COGO menu is found next to the Draw menu in MAP view. Below you will find each feature described.

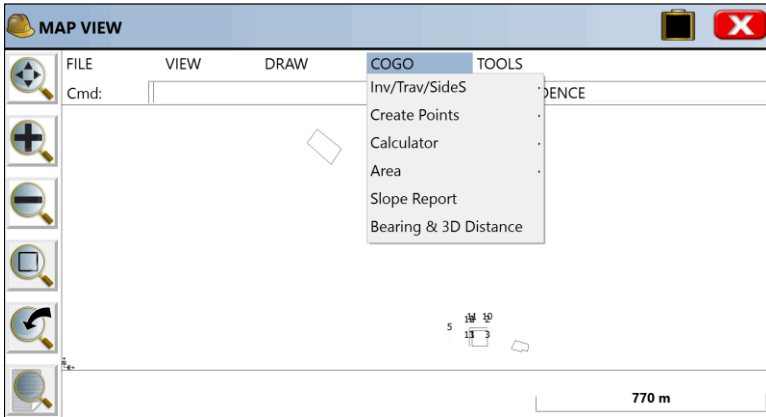



## Inverse (I):

Inverse command Inverses and presents the bearing and distance between point numbers. It has the added benefit that the previous point inverted becomes the backsight, and the current point inverted becomes the occupied point, allowing you to sequence directly into the Traverse or Sideshot commands. (Use angle code 7 to turn an angle right from the backsight to the foresight.) The "snaps" are available in inverse, so you can calculate the distance from a point to a line by "snapping" to endpoint, intersect, perpendicular (as shown below) or nearest.

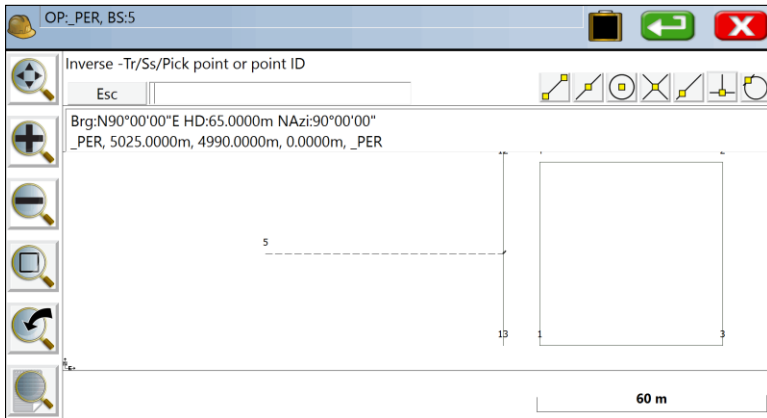

## Traverse (T) (also TR):

Similar to the Sideshot command, the Traverse command will “move up” to the last point traversed, holding the previous occupied points as the backsight. Exit with Esc.

## Sideshot (SS) (also S):

This allows for sideshots from any point that is “occupied” by use of the inverse command. For example, if you inverse from 126 to 150, you are “on” 150 and backsighting 126. Then at the prompt "Cmd: Inverse – Tr/Ss/Pick point or point No:", you can enter S for Sideshot. The first prompt is the Angle-Bearing Code: Sideshot-eXit/I/Tr/H/Angle-BC(1-7)<?>, which can be any of the following:

- 1-NE (0 through 90 if degrees, 0 through 100 if gons/grads)
- 2-SE (same as above)
- 3-SW (same as above)
- 4-NW (same as above)
- 5-Azimuth (360 circle if degrees, 400 circle if gons/grads)
- 6-Angle Left (degrees or gons)
- 7-Angle Right (degrees or gons)



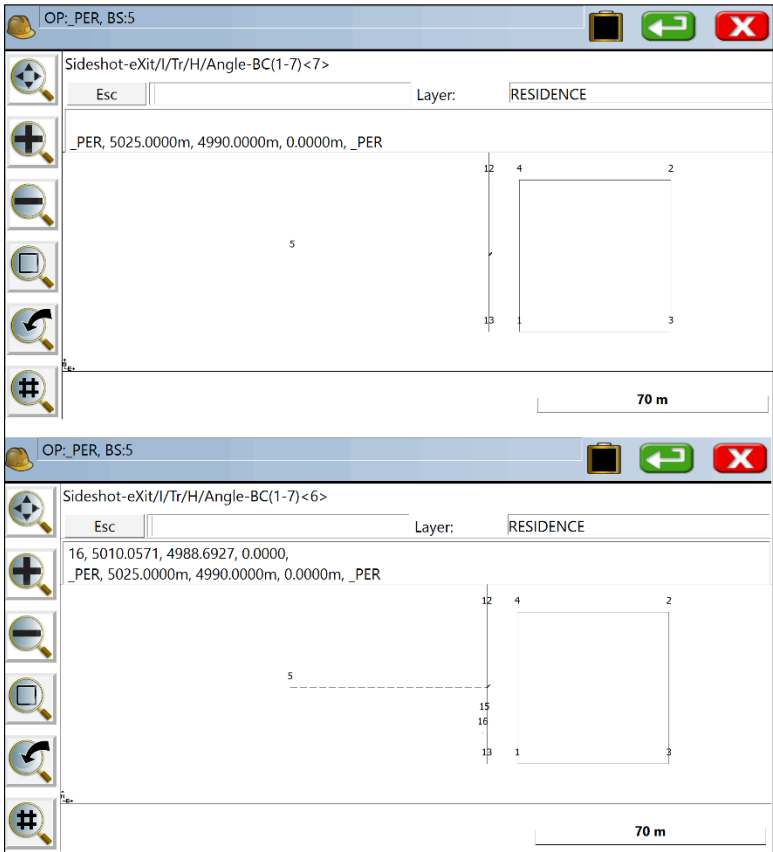
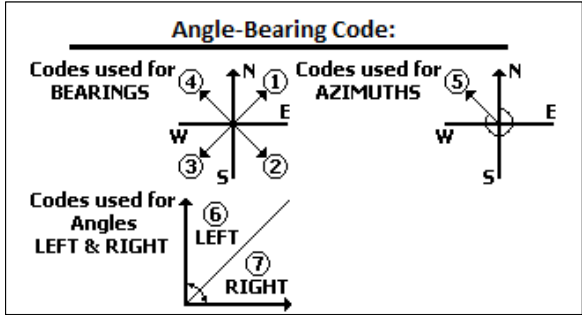

Note that at the Angle/Bearing prompt, you can transition back to inverse (from your occupied point) or to traverse, which would move you up to the next traversed point. Code 7 turns angle right. In the standard MAP screen prior to selecting T or SS, if you click the lower left View Options button, and then select the Data tab and choose Traverse Defaults, you can turn on the Zenith Angle or Elevation Difference prompts.





Then sideshot and traverse entries can be used for hand-entry of field data. Within Sideshot, you stay on your current point, holding the backsight, and foresighting (calculating) as many points as desired. X returns to the MAP screen as does Esc.

After the angle code, the remaining prompts are the angle itself (as in 85.3522, DDD.MMSS), zenith angle, slope distance, description and point ID. Exit with Esc anytime. In gons/grads, angles are also in decimal form, and angles such as 397.9871 are valid. The lower left icon within the sideshot/traverse routine, as shown above, leads to a "Find Point" option.

### Create Points - Draw Locate Points (DrawLP):

This command creates points at endpoints and intersections of polylines, based on use of the "snaps". In the example below, point 23 was created at the northeast endpoint

 of the building on lot 88, point 24 was created at the intersect  of the driveway and the lot frontage line and point 25 was created at the center of the arc  of the pavement line. The "snaps" from left to right are endpoint, mid-point, arc center/insertion, intersection, nearest, perpendicular and tangent.

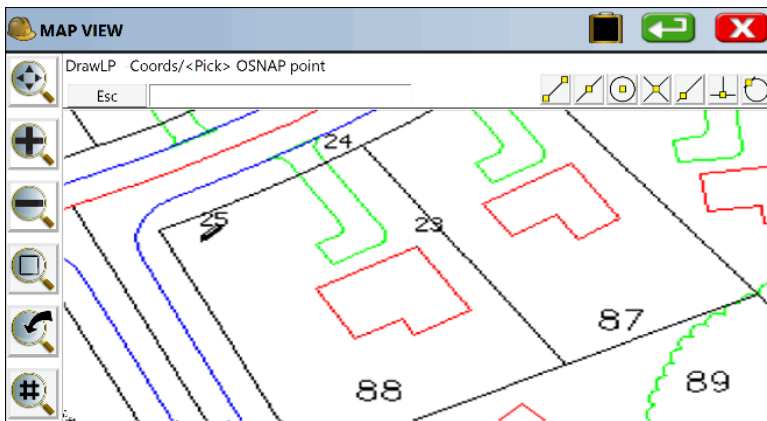



### Create Points - Polyline to Points (P2P):

This command converts any selected polylines into points. It is useful in capturing points for stakeout from polylines created as offsets or brought in from DXF files. This allows you to react to circumstances in the field by creating points from polylines, when and where needed. For example, if you wanted to make point numbers out of the lot corners below on the SW lot, Select Cogo, Create Points, Polyline to Points (or more simply enter P2P at the command line). Then pick each desired polyline. The program will avoid making duplicated points on vertices that already have point IDs.

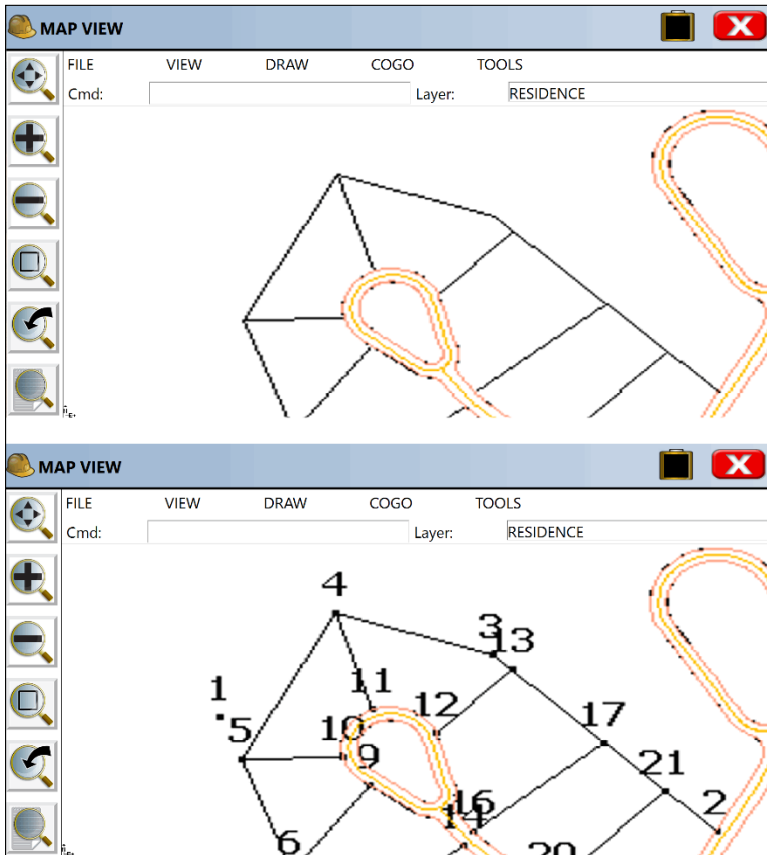

The new points are shown in “large” format, for emphasis.



### Create Points - Divide Along Entity (DVS):

This divides a polyline into the number of segments entered. A dialog will allow you enter in the number of segments. There are settings to prompt for descriptions and elevations and to create points at the end points of the polyline.

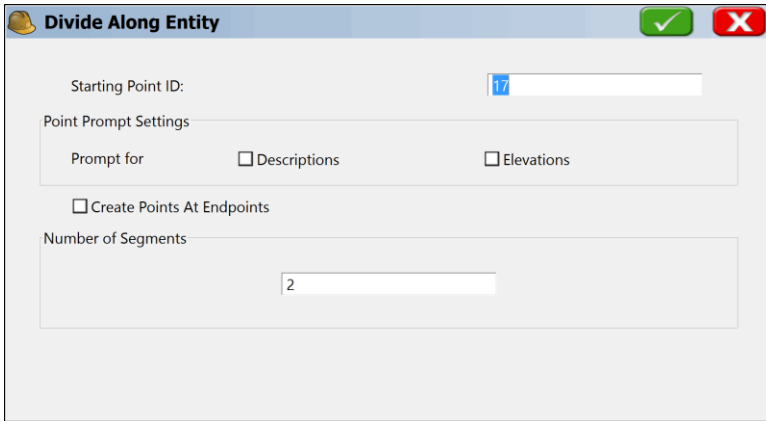

The command will create new vertices along the polyline but can also create point numbers starting at the entered Point ID, and you can elect to be prompted for descriptions and/or elevations at each new point. If a property line were divided into two segments, you would create three new points, if Create Points at Endpoints is clicked on. Otherwise, division of a line into two segments would create only 1 new point ID, in the middle of the line or polyline.

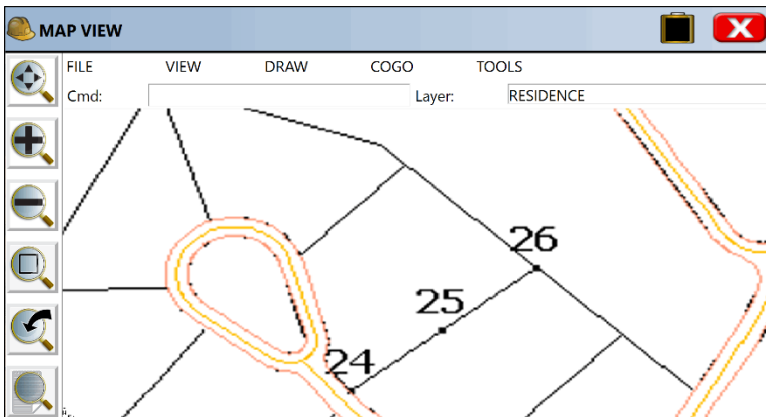



### Create Points - Interval Along Entity (DVI):

This divides a polyline by the distance entered. Curves can have a different interval. There are settings to prompt for descriptions and elevations and to create points at the end points of the polyline.

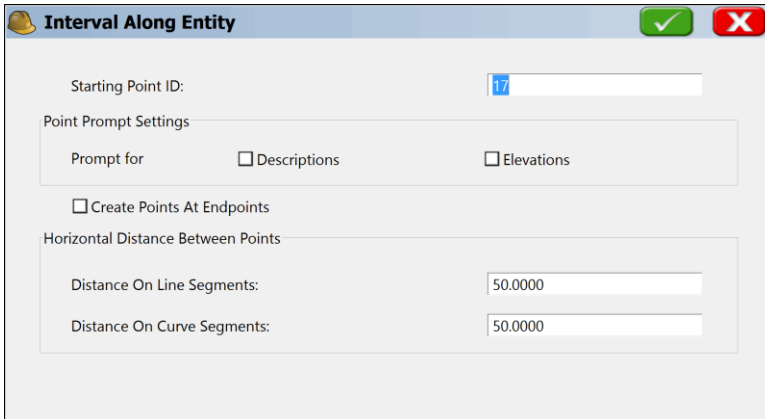

This command is often used for creating points on centerlines. Note the program resets the interval at break points like PI's and PC's. Note that you can choose to create more points at a smaller interval going around curves.

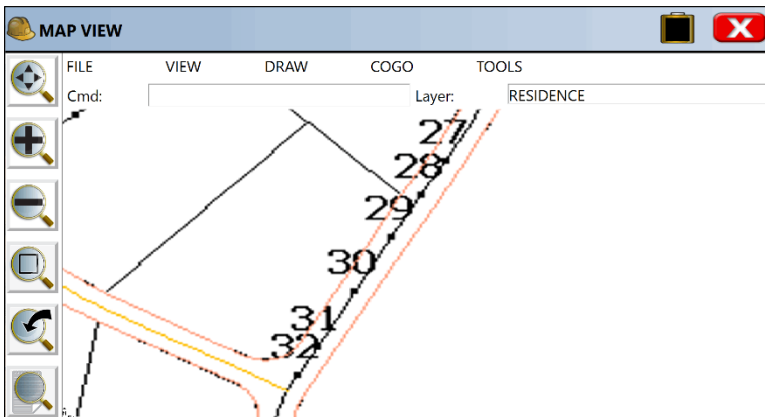

### Triangle Calculator (TC):

Goes directly from the MAP view to the Triangle calculator. See COGO - Calculator for detail.



### Curve Calculator (CC):

Shortcut to the curve calculator, then returns to MAP. See COGO - Calculator for detail.

### Area (AR):

This will report the area of any picked polyline. If you pick an unclosed polyline, the program will draw a temporary line for the closing segment and report the area.

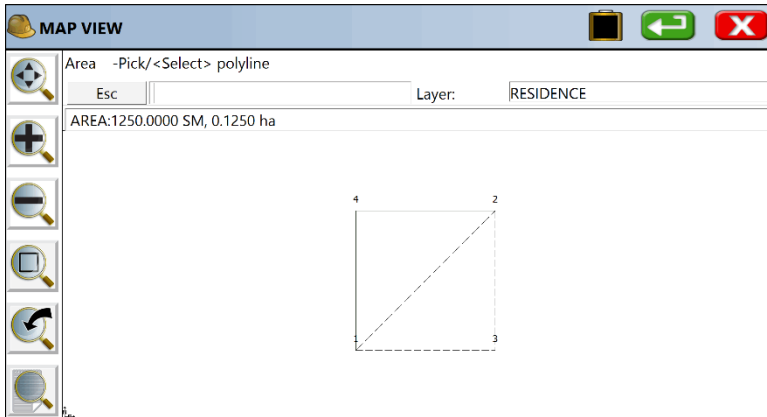

### Hinged Area (HA):

This command can be used to determine the dimensions of a figure when the area is fixed and three or more sides are known. The figure must be defined by a closed polyline. After executing the command, select the polyline. Next, select the hinge point. The polyline segment clockwise from your hinge point will be the segment to move. SurvPC will then ask you if you want to keep the existing polyline. If you answer Yes, a new polyline with the desired area is created, if you answer No, the polyline you pick is modified. Next, the current area of the polyline is shown. At this point, enter the new area in the units specified under Job Settings. (If your units are set to feet, the area will be specified in square feet). See the top-left figure below.

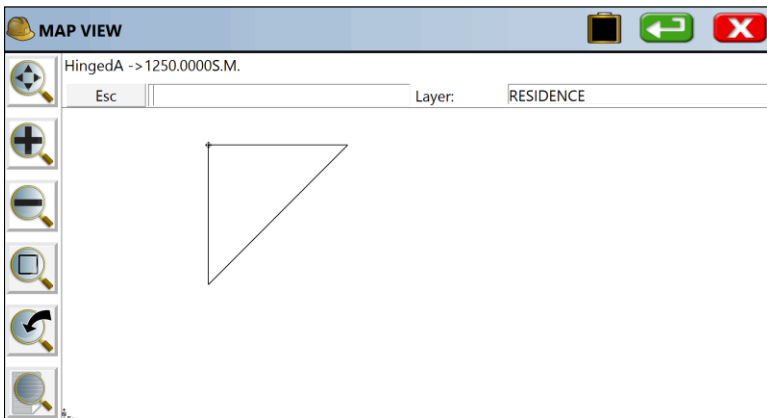
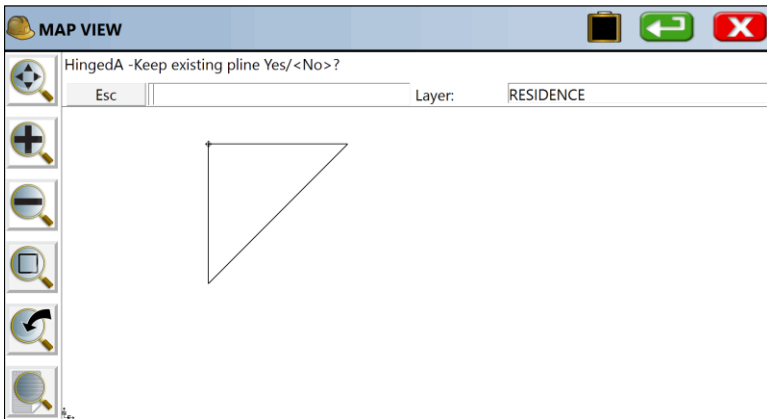
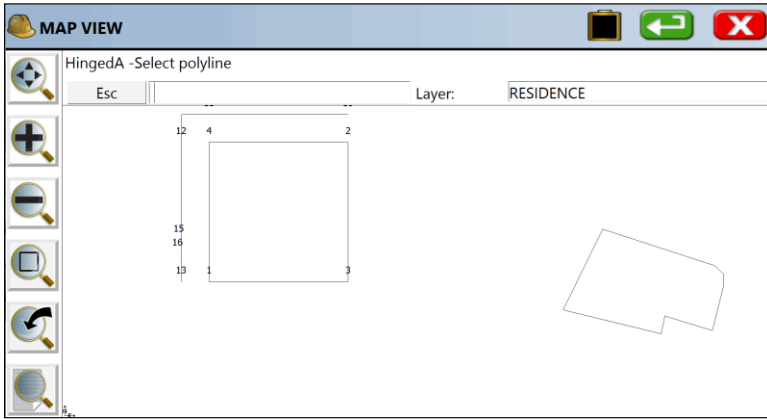

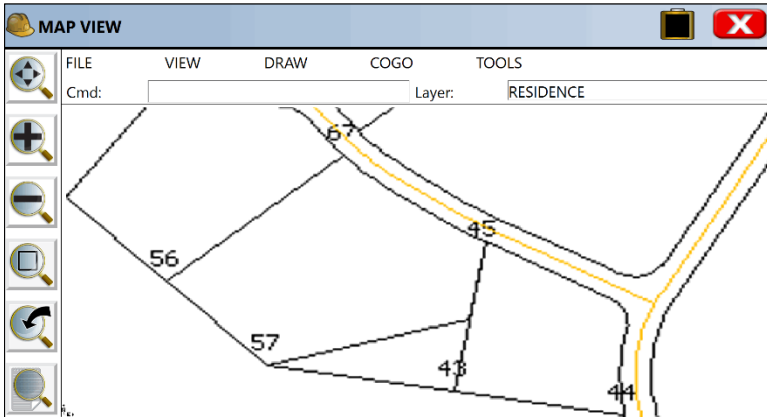

Note how the hinged side occurred on the clockwise side of the polygon perimeter (side 57 to 43). If we erase the new polyline, reverse the original polyline (RV) and repeat the command, this time answering “No” to “Keep existing” and again targeting 24000 Sq. Ft. area, we get the following:

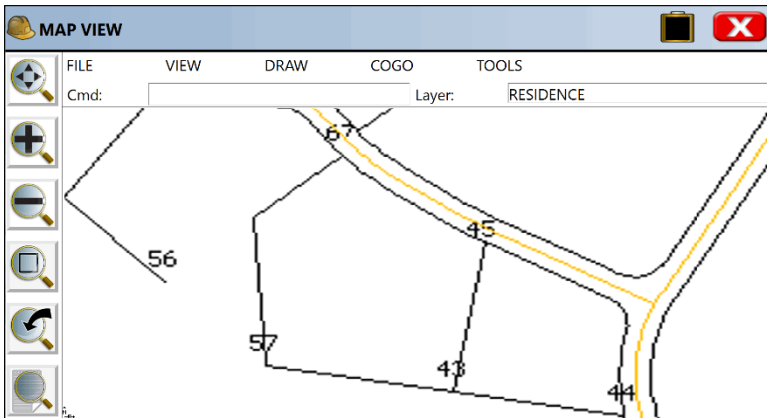





### Sliding Area (SA):

This command adjusts one side of a polyline to meet a specified area. You must specify the new area in the same units as specified under Job Settings. The area to adjust must be a closed polyline. After executing the command, select the polyline. SurvPC will then ask you if you want to keep the existing polyline. If you answer Yes, a new polyline with the desired area is created, if you answer No, the polyline you pick is modified. Next, the current area of the polyline is shown. At this point, enter the new area in the units specified under Job Settings. (If your units are set to feet, the area will be specified in square feet). Let's choose to divide our new parcel into two equal areas of 12,000 square feet each.

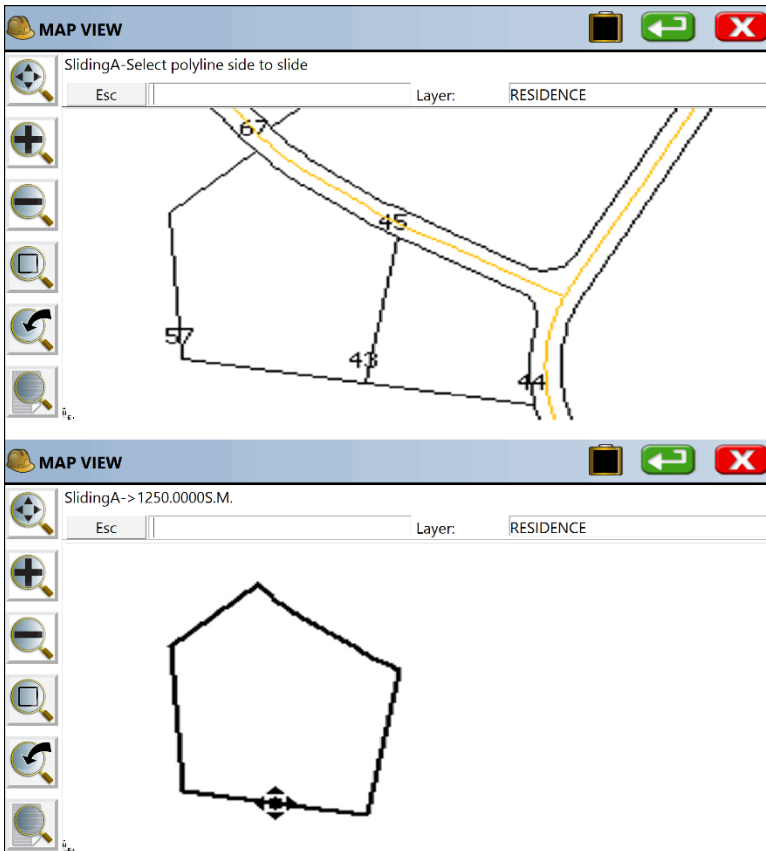

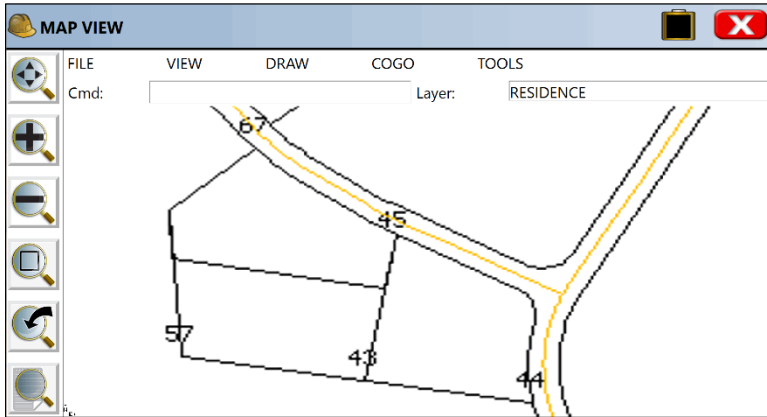

### **Slope Report (SR):**

This command reports the horizontal area along with the slope area of a figure defined by a range of points. The command actually executes the TRIANGULATION command to compute the slopes within the defined area. There are options to include breaklines, use a predefined TIN model, and prompt for inclusion/exclusion areas. If you use a TIN model, you should click on "Prompt for Inclusion/Exclusion" and then pick perimeters where the calculation will be applied.

Consider the figure defined by points numbered 570, 97, 569, 584, 585, 75, and back to 570 as shown below. From the COGO AREA command, we see that the horizontal area of the enclosing polygon is 11,653.4122 Sq Ft. Performing the SLOPE REPORT yields the same horizontal results, but also reports the slope area, and the maximum, minimum, and average elevations and the average slope within the area.

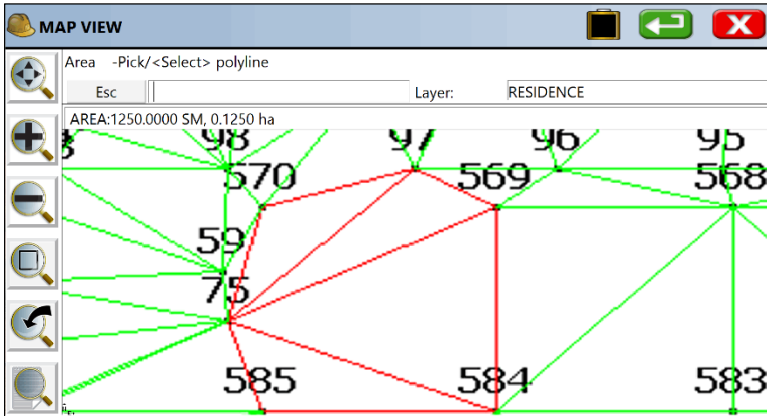

Triangulate & Contour

Points

Range of Points: ALL

Wildcard descriptions:

Include:  Breaklines  Contours

Use Triangulation File

Select File None

Prompt for inclusions/exclusions

Slope Report

Horizontal Area:  
4375.0000SQ. METERS  
0.4375HECTARES  
1.0811ACRES  
47091.9197SQ. FEET  
47092.1080SQ. INT'L FEET  
0.0017SQ. MILES  
5232.4336SQ. YARDS

Slope Area:  
4375.0000SQ. METERS  
0.4375HECTARES  
1.0811ACRES  
47091.9197SQ. FEET  
47092.1080SQ. INT'L FEET  
0.0017SQ. MILES  
5232.4336SQ. YARDS

AVERAGE ELEVATION: 100m



### Bearing & 3D Distance (3D):

This command reports the horizontal distance, elevation difference, slope distance, vertical angle, percent slope, slope ratio, bearing and azimuth between two 3D points. The user can pick or enter the number of two points, select a polyline segment or pick two points on any polylines from MAP using the "snaps". Within the report screen, clicking the disk icon on top will create a Txt file of the inverse for export.

The screenshot shows the MAP VIEW software interface. The top window is titled 'MAP VIEW' and contains a toolbar with icons for navigation and a '3Dist --<Calculate>' command. Below the toolbar, there is a text input field with 'Esc' and a 'Layer:' dropdown menu set to 'RESIDENCE'. A large empty rectangular area is visible below the input fields. The bottom window is titled 'Bearing & 3D Distance' and displays the following data:

```
First Point: 1
Y=5000.0000, X=5000.0000, Z=100.0000,
Second Point: 3
Y=5000.0000, X=5050.0000, Z=100.0000,
Horiz. Dist. = 50.0000
Elv. Diff. = 0.0000
Slope Dist. = 50.0000
Vert. Ang. = 0°00'00"
Zenith Angle = 90°00'00"
Slope percent = 0.00%
Slope ratio = 0.00:1
Bearing = N90°00'00"E
North Azimuth = 90°00'00"
South Azimuth = 270°00'00"
```



## 9.6 Tools



The Tools menu is found next to the COGO menu in MAP view.

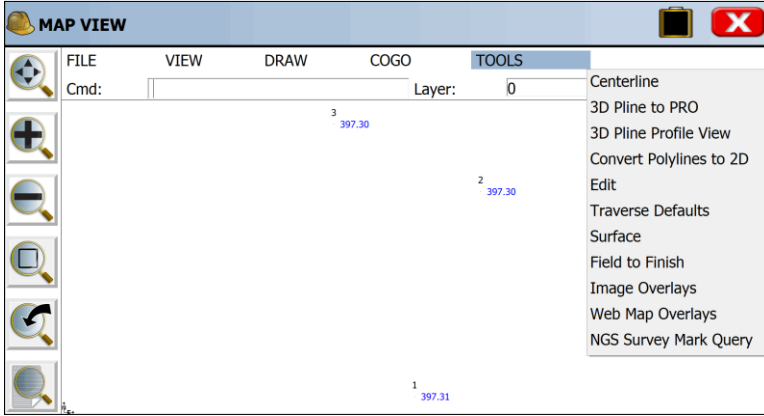



### Centerline - Polyline to CL (P2CL):

Converts any polyline into a centerline file for use in the Roding commands and in Centerline, Curve and Offset Stakeout. You will be prompted for starting station and the name of the centerline (horizontal alignment) file, and you will obtain a centerline report. To station the polyline in the opposite direction, use Reverse Polyline (RV), or select Draw, Modify, Reverse Polyline to change the direction of the polyline prior to issuing the command. If we choose the existing polyline as shown, we obtain the following CL file report:

MAP VIEW

Pline2CL-Undo/Beginning Station<0+00.000m>

Esc | 0+00.000 | m Layer: RESIDENCE

Warning:  
Polyline should have been drawn in direction of increasing stations.

Station	North(y)	East(x)	Desc
0+00.000m	5050.0000	5050.0000	LI
0+50.000m	5050.0000	5000.0000	LI
1+00.000m	5000.0000	5000.0000	LI

### Draw CL to Map (CL2P):

This command draws a POLYLINE entity using the data from a centerline file. You can practice this command by selecting the file Demo.cl, provided with the program. It draws in the current layer set within the View pulldown, Layer command.



### Polyline Smooth Test (IsSmooth):

Select a polyline to verify smoothing. A polyline with tangent curves would report "Smooth Polyline: No deflection angles greater than 0 degrees detected." A polyline such as a right-of-way line or top-of-bank line in a roadway design (see below) would report all angled points of intersections (PI's). The purpose of the command is to detect alignments that have non-tangent curves or PI points without curves. It is also useful to verify whether alignments such as rights-of-way have perfect 90 degree, right-angle deflections. The centerline with tangent curves in the graphic below, for example, reports "Smooth Polyline", while the top-of-bank polyline (see arrow) reports the information at right.

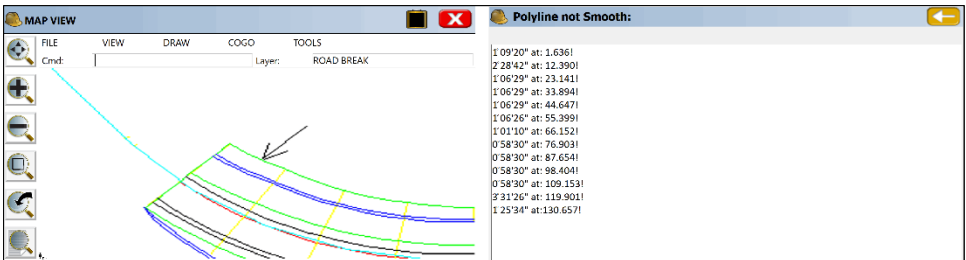

### 3D Pline to PRO (3DP2Pro):

Pick any 3D polyline and create a profile. If you pick a polyline at 0 elevation, the program will warn, "Cannot create PRO file. Not a 3D Pline! Please select another Polyline." If you pick a polyline that has vertices with elevations, a profile or vertical alignment file (.pro extension) will be created and can be reviewed and edited within the Roads Menu command, option Profile Editor. You can set the starting station. Keep in mind that for alignments with curves, 3D polylines must use chords with many vertices since the program cannot present 3D polyline arcs. Because chords reduce the distance around arcs, stationing may not match the true 2D alignment. This would not impact straight alignments or deflection-type alignments such as for electric, telephone and water lines or sewer lines running between manholes.



### Convert Polylines to 2D (C2D):

Pick any 3D polyline or contour polyline at uniform elevation and convert it to 2D (elevations of vertices are set to 0). Helpful when doing the Fillet command, for example, which requires a 2D polyline.

### Edit - Polyline (EDP):

Remove vertices, insert vertices and update (alter) the coordinates of any vertex. For example, if we pick the centerline that was used above, we obtain the edit dialog, with options to add or remove segments or arcs, edit curve information, etc. Saving changes updates the graphics on the screen. Double-clicking any line is equivalent to tapping Update.

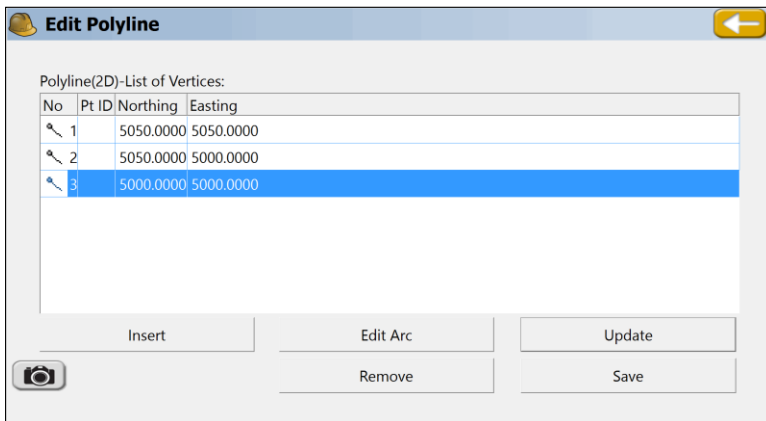





## Edit - Input-Edit GIS Data (EGIS):

This command allows you to input or edit GIS attributes associated with an entity. Select the entity from the screen or for the case of a closed polyline, pick inside the area defined by that entity.

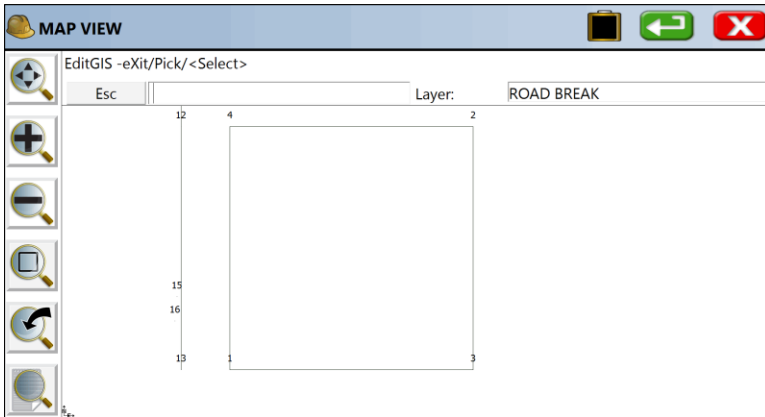

Only polylines (open or closed) can be selected. This command does not apply to attributes associated with points (use List Points to edit point attributes). Attributes are associated with points, polylines and polygons (closed polylines) either through use of feature codes or by importing shape files or dwg files exported from ESRI products. If a polyline is closed, you can use the Pick option and simply pick inside its interior. This "Road" description included a "Surface Material" attribute, which now can be edited. Drawings that are exported using "Export to CAD" from ArcMap 9.1, 10.0 or 10.1, when imported within SurvPC, will include many GIS feature options that can be selected in the top pulldown and assigned to the selected polyline, with corresponding attributes. The "Recall" button will display the last attribute values chosen for any feature such as "BLD" (for buildings in this case) or "SW" (e.g. for sidewalks). GIS attributes can be exported to ESRI using the commands Export Shape Files or Export .dwg.

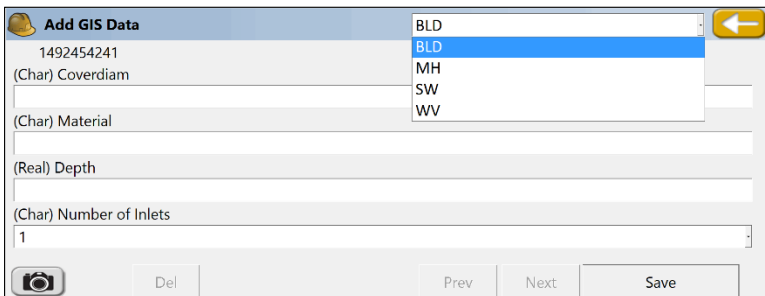



### Copy GIS Data (CGIS):

Select a source entity to extract GIS data from and then apply it to a destination entity. So, if one building has GIS data that applies to another building, you pick the source building and then select the destination building and it then shares the same GIS data.

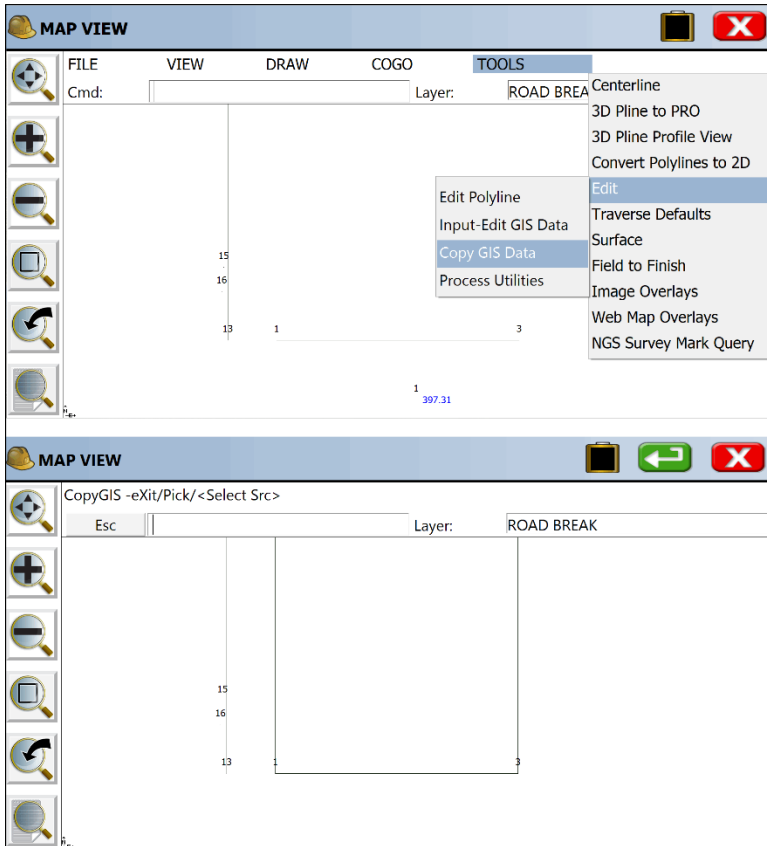

<Select Src> is the prompt to pick the source entity with existing GIS data, following by <Select Dst> which prompts to select the destination entity to apply the GIS data to. The program warns if the source entity has no GIS data. You have the option to edit the destination data, so if you copy the GIS attribute "Number of Stories" for a building, you can edit the destination data, for example, from 3 stories to 2 stories, within this copy procedure.



### Traverse Defaults (TD):

This sets the elevation prompting (none, vertical, zenith, elevation difference), within the Traverse and Sideshot commands within the MAP view. Also enables a prompt for Instrument and Rod Height. Default setting is no instrument or rod heights and no vertical angle prompting, so inputs are simplified as angle/bearing code, angle/bearing, distance, description, point number. Traverse and Sideshot entries within the MAP screen are stored to the RW5 file unless this option is clicked off at the bottom of the dialog.

**Note:** 3D MODE must be enabled in **Equip/Configure** for this dialog to become active. Otherwise, choices are "grayed out."

**Traverse Defaults**

Prompt for:

Instrument & Rod Height

Vertical Angle Prompt:

None

0 Degrees Level

90 Degrees Level

Elevation Difference

Raw File:

On  Off



### Triangulate & Contour (TRGC):

Triangulate and Contour can create a final contour map based on user given data: points, polylines. This function has many options which are specified in its dialog box. The routine will prompt also for inclusion and exclusion polylines. You can use exclusion polylines to avoid contouring within buildings, for example. If you have no exclusion polyline (or no inclusion polyline), press Enter to continue. To delete entities drawn with this command, turn off all of the drawing options and reprocess or use the View pulldown menu and isolate to the layers involved then erase all objects.

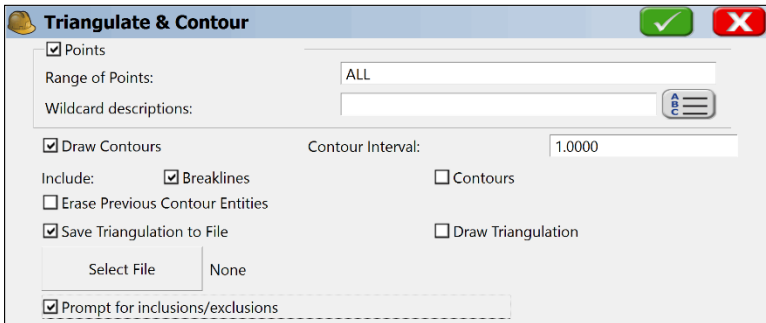

If "Prompt for inclusions/exclusions" is turned on, then the first selection is for the inclusion and optional exclusion polylines. If a ".tin" is saved, it can be recalled in commands such as Elevation Difference and used for stakeout and determination of cut and fill. If "Draw Triangulation" is turned on, the triangulation lines will be drawn. When selecting entities for contouring and triangulation, there are 3 types of entities that can be selected: Points, Breaklines and Contours. Points would be point IDs, breaklines would be 3D polylines and contours would be 2D polylines at non-zero elevation.

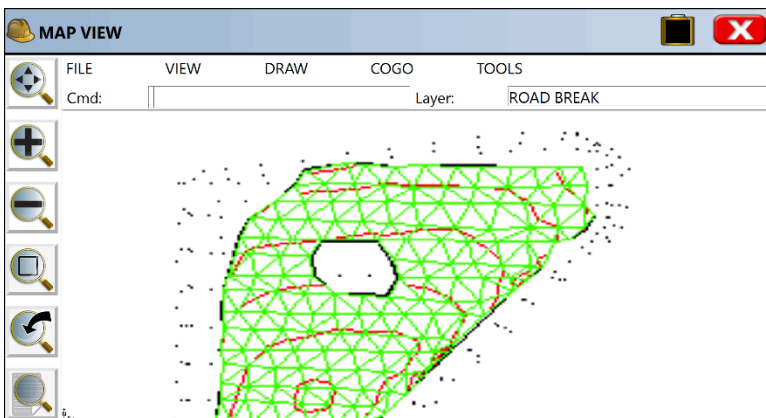



### Volume (VOL):

Volumes can be computed by several methods, using surface files (e.g. ".tin" files), point ranges and/or layers to define existing and final surfaces. Perimeters can be used to further limit the area of the volume calculation.

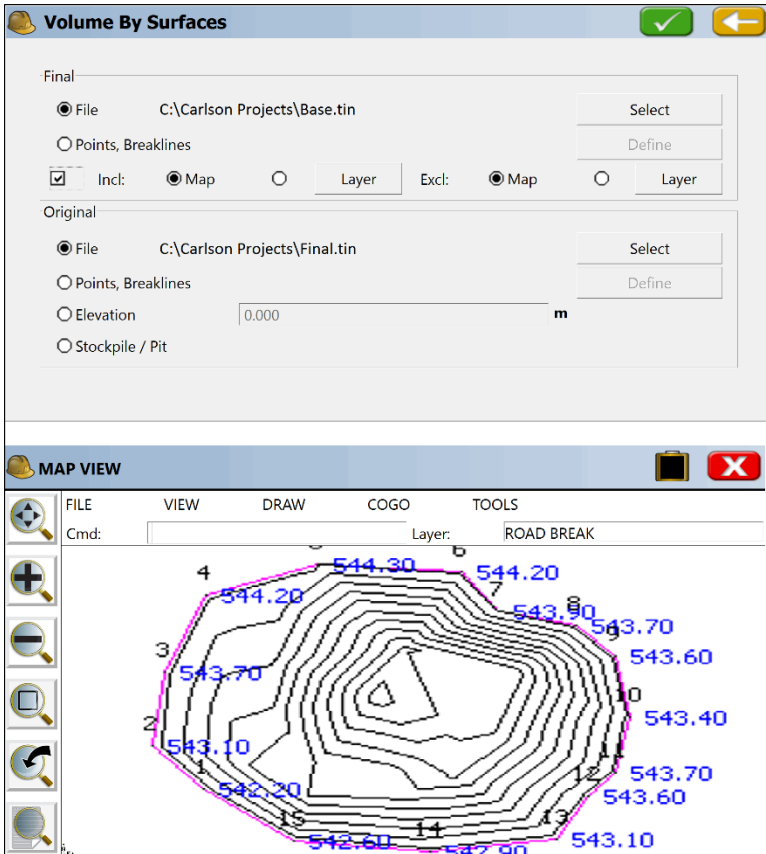

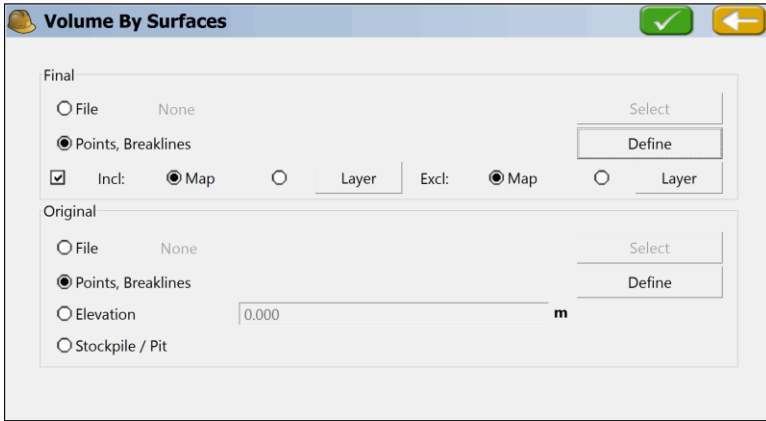

In the example above, two tin files are used to define the surfaces for volume calculation, as enclosed by an inclusion perimeter. Below that, the base surface might be defined by points 1 to 15 and the final surface defined by the contour and perimeter layers. Referring to the graphic below, which illustrates the same stockpile as above, the “Final” point range could be defined as ALL points, and the “Original” point range could be defined as the base points of the stockpile or points 1-15. Use the “Define” button to specify the desired layers and point ranges to include in the calculation for original and final surfaces.

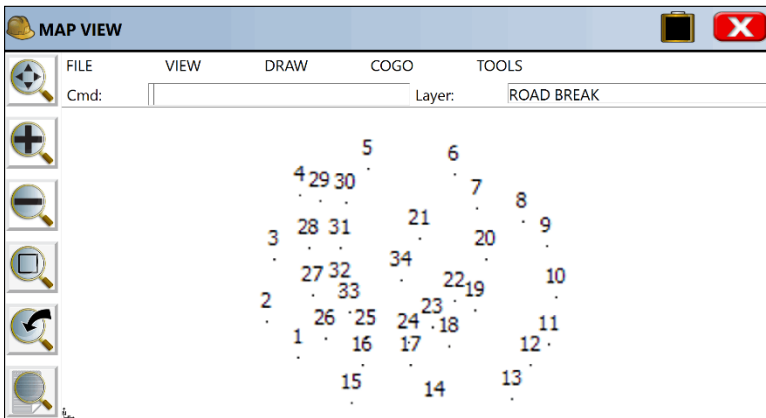

So, using the settings above in the Volume routine, you would verify your two point ranges, then click OK. For example, the “Original” surface point range would be set as follows using the “Define” button for “Original” prior to clicking OK.

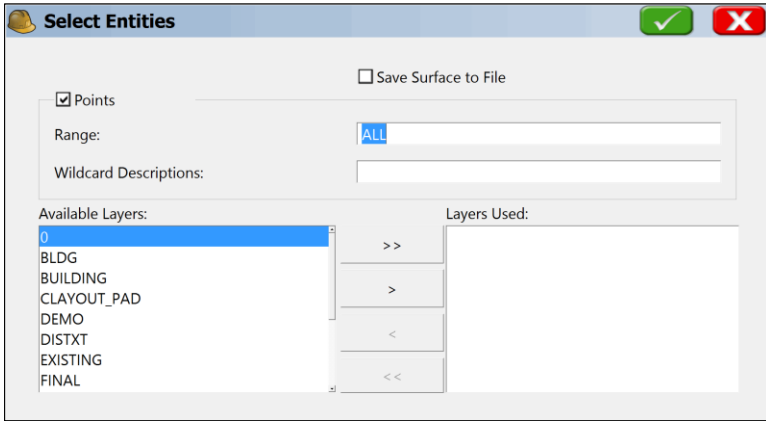

Clicking OK moves forward to a shrink and swell factor screen. Only if you are set to English units do you get the option for tons based on a density factor. In metric units, the volume is presented in cubic meters. You can create a new surface TIN file that merges the original surface with the final surface within the selected or assumed perimeter. If you do not have an inclusion perimeter, then the largest "convex" figure defined by all final surface points and entities becomes the default perimeter.

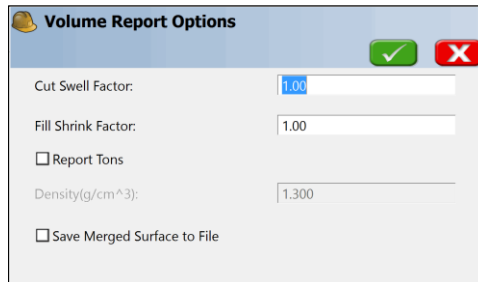

Clicking OK continues on to the Volume Report.

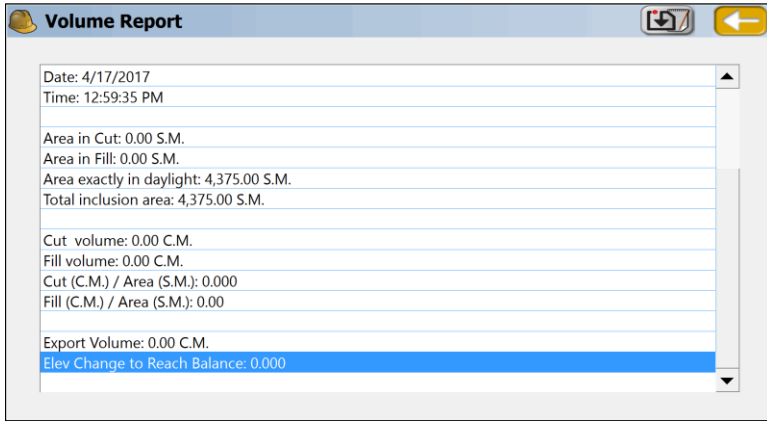

The report can be saved to a text file using the “Save to Disk” icon at the top of the screen within “Volume Report”. Click the “Return” arrow to continue back to the Map screen. If you draw a 3D polyline perimeter connecting points with elevation representing the outer limits of the volume calculation (using Draw, Polyline, 3D), then you can click on Inclusion and use the polyline as an inclusion perimeter. You can also use drawn elements on different layers as part of the volume calculation, if they are 3D, by moving them over to the right-column using the “Define” button. Volumes can also be conducted between “File” surfaces, TIN files made with Triangulate & Contour or within the Volume command itself using the option “Save Merged Surface to File.”

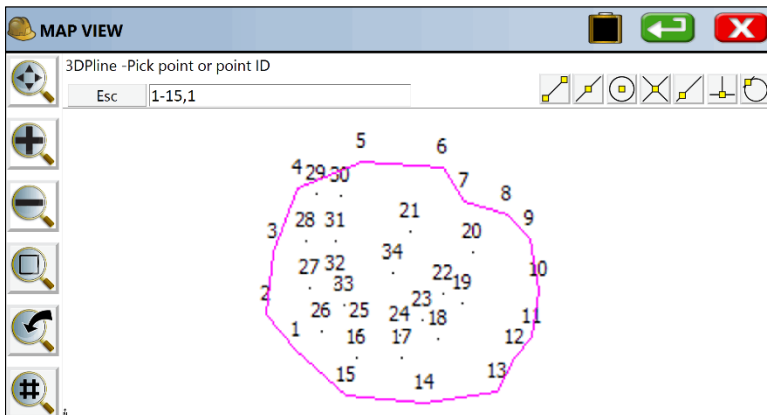

Finally, if you are doing a stockpile and make the effort to put this outer perimeter in the “Perimeter” layer, then you can select the “Stockpile” option within Volume, define the final surface appropriately, and click OK. You don't need any other definition for the original surface. This is because the Perimeter layer will define both the inclusion perimeter and the original surface in this case.



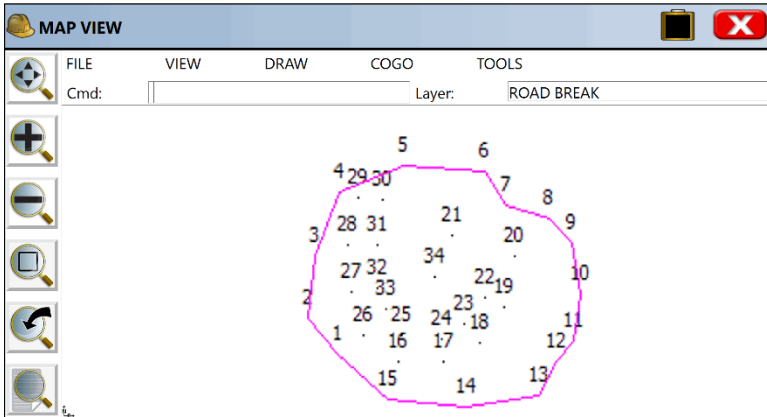

**List Elevation (LELV):**

This command allows the user to pick on an entity and retrieve the elevation of that point. If you pick on a 3D polyline, you will get an interpolated elevation at the picked point.

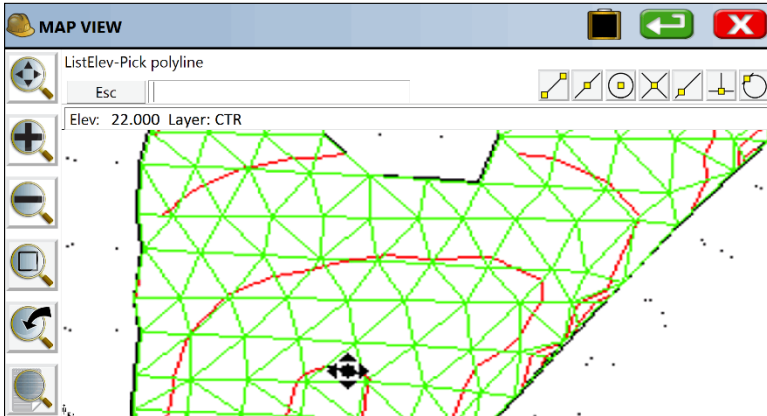



### Field to Finish (F2F):

This command will redraw the linework created with Feature Codes based on the current coordinates of the points. So, if a GPS file was “processed” using a new localization, or a total station survey was adjusted, the existing linework made by use of Feature Codes will erase and redraw by connecting to the adjusted coordinates. In this way, polylines on the MAP screen created by field surveying will be redrawn to recapture their association with the adjusted point coordinates. Note that linework created by Feature Codes will redraw automatically in all graphic screens after coordinate positions or descriptions are edited within File-Points. The F2F command will restore linework to point-based positions after erasing or moving linework on the screen.

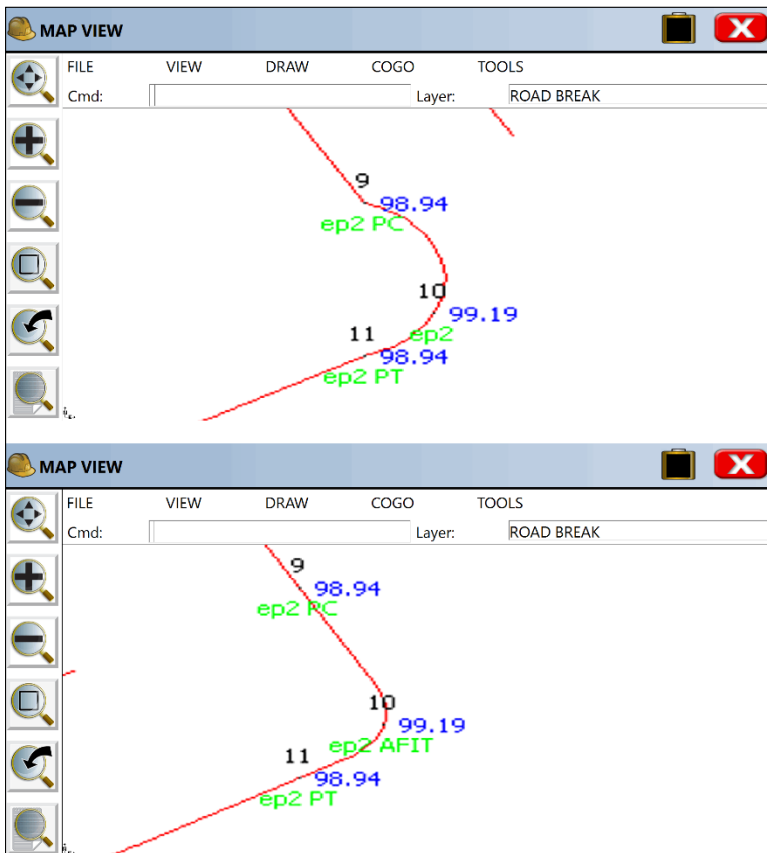

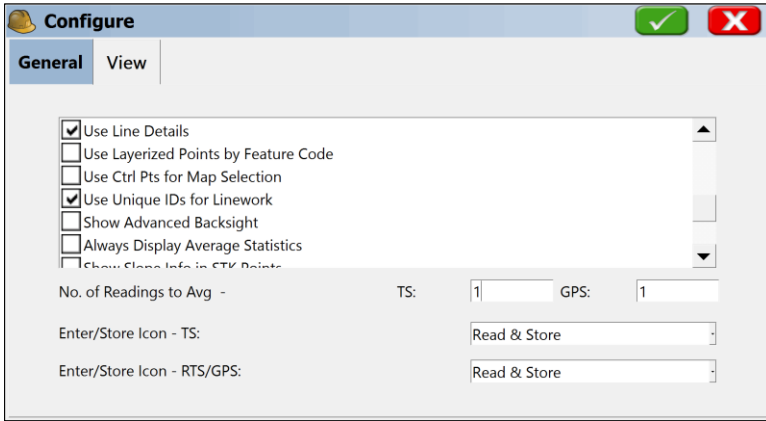

In the example above, a field survey of a curve through points 9, 10 and 11 created a bulging curve due to erroneous measurement(s) of the true PC of the 3-point arc. If point 10 is clicked and edited with the field code EP2 AFIT, the AFIT (or as user-defined in the Special Codes within Feature Codes) on the middle curve point will force a tangent arc and adjust the true PC and PT points, keeping the field-measured points on the tangent. Then if Field-to-Finish is selected within the Tools menu, the curve will redraw. Note also that within Equip, Configure, if "Use Line Details" is clicked on, this setting has the effect of automatically re-drawing the linework upon any edits, without selection of Tools, Field to Finish.

When using Field to Finish, any line that is not ended with an "end" or "close" code will be detected and presented. These are very common when using the "counter" or appended number method of coding. This refers to coding a first EP as EP1, EP1, EP1, and a second EP as EP2, EP2, EP2. In this case, no end code is used--the suffix on the EP indicates which line is being coded and drawn. When these types of codes are selected (versus EP, EP, EP End or EP ST, EP, EP) then you may be prompted as shown below. Typically, choose the option "End All". This same screen is obtained by choosing the option "V" for Review (versus Redraw) when first selecting the command. Update and Redraw accomplish the same thing



## Image Overlays:

This command will attach an image database to the SurvPC drawing. Image databases are georeferenced aerial photography or image maps. These image databases can contain multiple large images that have been processed for quick display in SurvPC. The boundary for the image-set is shown by a dashed line. Images are inserted in coordinate system and units of the image. Image databases are processed with the Image X-Port utility of Carlson X-Port and take the form of IMD or IDB files. Only using SurvPC, can images be directly imported as jpg, tiff and other forms. The option to Save Image Boundary Points creates points at the 4 corners of the image, allowing you to zoom to those points. However, Zoom Extents (upper left icon in MAP screen) will zoom to the extents of the image if no points exist in the file.



Images that do not have any georeferenced information built into them (or available in a separate jpw or tfw file) must be calibrated within Carlson X-Port, the office software companion to SurvPC, using the Image Manager. GeoPDF format is supported.

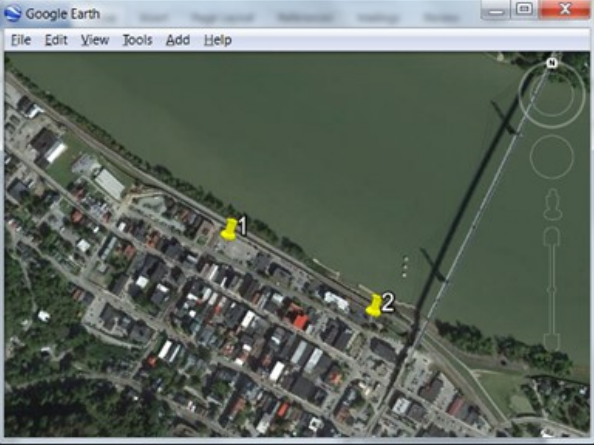

**Geo-Calibrate the Google Image**

- Collect at least two points that can be located on a Google Image.
- Export points to KML.
- Import the KML file into Google Earth.
- Save the Image with Google Earth. File Save /Save Image.
- Using Carlson Image Manager create a world file with Tool, Geo-Reference by User Points.
- Process the Image with Image Set Manager.

### Web Map Overlays:

This command will allow for online maps to be applied to the background of the map screen. Current options are Google and OpenStreetMaps. For this option to function properly, the PC needs to be connected to the internet.

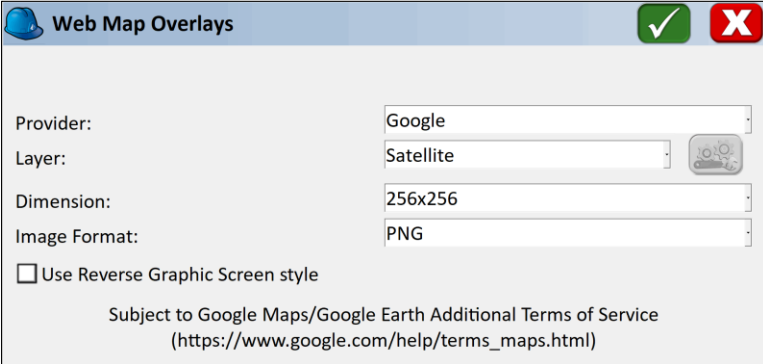

**Web Map Overlays** [Checkmark] [X]

Provider: Google  
Layer: Satellite  
Dimension: 256x256  
Image Format: PNG

Use Reverse Graphic Screen style

Subject to Google Maps/Google Earth Additional Terms of Service  
([https://www.google.com/help/terms\\_maps.html](https://www.google.com/help/terms_maps.html))

**Active:** This allows for the user to activate the web map overlay (if checked).

**Provider:** This allows the selection of the web map overlay source (Currently OpenStreetMap or Google).

**Dimension:** This allows for selecting the size of the web map overlay. Options here are:

- 256x256
- 512x512
- 1024x1024
- 2048x2048

*Note that smaller resolutions will use less data and load more quickly.*



**Image Format:** This allows for selection of the web map overlay format (either JPEG or PNG).

Once the preferred selections are completed, the web map overlay will show in the Map screen.

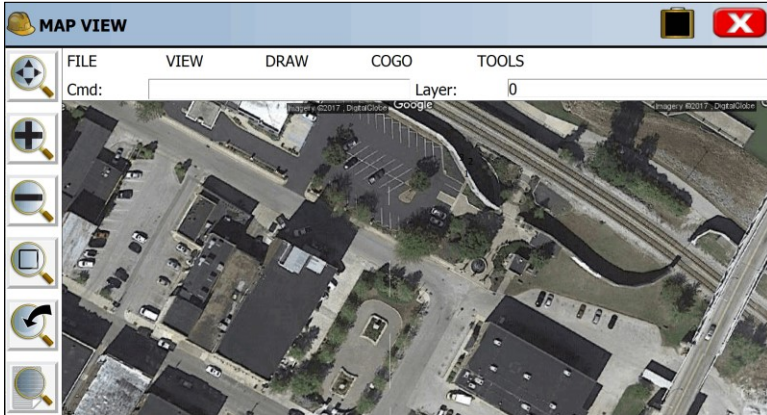

### NGS Survey Mark Query:

This command will search the published NGS database for all recorded monuments or control points stored on the NGS website, within a specified radius of the current position. It requires an internet connection by cell phone or wireless.

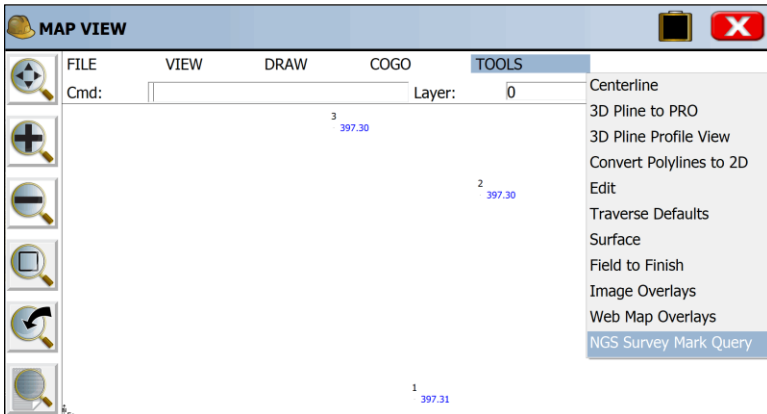



**NGS Survey Mark Query**

Projection: UTM/WGS 84/Automatic Zone Selection

North  South

Lat(dd.mmssss): N 0°02'42.80502"

East  West

Lon(ddd.mmssss): W 85°26'40.398285"

Search Radius (Miles): 0.25

Search NGS Datasheets

Select File

**NGS Survey Mark Query**

Search is complete

1%

Cancel

The default Search Radius is the area shown within the current Map Screen view. The latitude and longitude are calculated from the map coordinates and current projection. Since this is a NGS (US only feature) the search radius is in decimal miles. Search NGS Datasheets will get all the datasheets for this search radius. You can expand the Search Radius further as desired. The program sends a request to the NGS web site. Please be patient while the data is being recalled--it may take several seconds. This will download a new search a copy it to a folder NGS\_Control\_jobname. The default name for the file is gis.xml. The information in these folders can be recalled (without internet connection) using Select File.



The points will appear in a list, as shown below, whether based on a fresh search or if recalled using Select File.

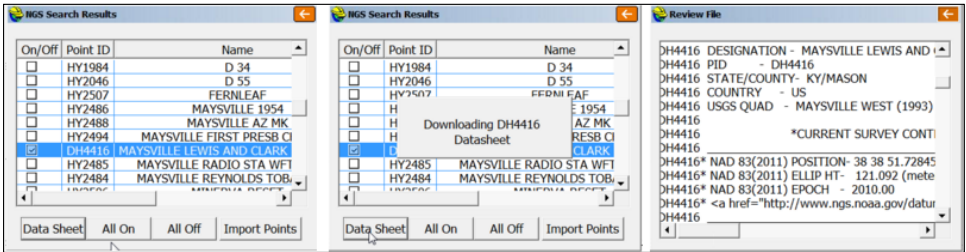

By default, all the recalled monuments are unselected (Off). You can select individually or Select All. If you highlight a point, you can study its full information by clicking Data Sheet. The button Map Points stores all selected points to the coordinate file, and they will display on the screen. If combined with an Image Overlay, points can be easily located for reference, usable as GPS control points or as control for total station measurement.





## 10 Tutorials

### 10.1 Tutorial 1: Calculating a Traverse (By Hand) with SurvPC

In order to do a hand traverse with SurvPC, go to the **MAP** screen by clicking the icon in the upper right corner (appearing as a globe). While in the map screen, select the **Map Settings** icon to set your Traverse Defaults



#### Traverse Steps:

1. To begin, you must key in the command for inverse by typing “**I**”. This will establish your occupied and backsight points. The command prompt will display the following:  
2. Cmd:Inverse - Tr/Ss/Pick point or point No
3. Key in the backsight point number followed by the **[ENTER]** key.
4. Key in the occupied point number followed by the **[ENTER]** key.
5. Key “**T**” for Traverse or “**S**” for Sideshot followed by the **[ENTER]** key.
6. If you keyed in “**T**” for traverse, the command prompt will be waiting for an angle code by displaying the following:  
7. Cmd:Traverse - eXit/I/Ss/Angle-BC(1-7)<7>
8. If you keyed in “**S**” for sideshot, the command prompt will also be waiting for an angle code by displaying the following:  
9. Cmd:Sideshot - eXit/I/Tr/Angle-BC(1-7)<7>
10. The code choices you can key in are as follows:
  11. 1 - Northeast Bearing
  12. 2 - Southeast Bearing
  13. 3 - Southwest Bearing
  14. 4 - Northwest Bearing
  15. - Azimuth
  16. - Angle Left
  17. - Angle Right
18. Key in the angle code of choice followed by the **[ENTER]** key
19. Key in the angular value in the dd.mmss format followed by the **[ENTER]** key.
20. If you selected a vertical prompt under **Traverse Defaults**, then key in the appropriate value followed by the **[ENTER]** key.
21. Key in the slope distance followed by the **[ENTER]** key.
22. Key in the point description followed by the **[ENTER]** key.
23. Press the **[ENTER]** key to accept the next available point number or key in a new point number followed by the **[ENTER]** key.
24. If you traversed, then you are now occupying the new point and are backsighting the previous point of occupation. If you sideshot the new point, then you are still at the previous setup and ready to compute the next point.
25. Options at the command prompt when presented with the messages listed in step 5 are as follows:  
X - Exit



I - Inverse

S - Sideshot

T - Traverse

*Note: in order to establish new occupied and backsight point information, you must use the "I" (Inverse) command and define the backsight point first and the occupied point second.*



## 10.2 Tutorial 2: Performing Math Functions in Carlson SurvPC Input Boxes

Many input boxes in SurvPC allow the user to calculate math functions "on-the-fly". To enter rod heights while in a GNSS setup screen that is not in your current units (e.g. you're using a 2 meter pole but working in U.S. feet), key in the following: The Rod Height followed by "m" for Meters, "ft" for Feet and "ift" for International Feet followed by the [ENTER] key will convert the measurement into your current units (e.g. 2m = 6.5617).

To compute the azimuth from one point to another to automatically enter in the azimuth while using the **Point by Direction** option in **Point Store**, key in the following:

**Point ID,Point ID** (e.g. "1,2")

To add or subtract a value from the computed azimuth, key in the following:

**Point ID,PointID+Angle** (e.g. "1,2+90")

Or

**Point ID,Point ID-Angle** (e.g. "1,2-90")



## 10.3 Tutorial 3: Defining Field Codes, Line/Layer Properties & GIS Prompting

SurvPC can have one pre-defined FCL (Feature Code List) file loaded with the job coordinate CRD file.

The Feature Code List file stores pre-defined field codes that define Line/Layer drawing properties and optionally GIS prompting. (More than one FCL file can exist but only one can be loaded at a time per job coordinate CRD file.)

The operator builds this FCL file using option 5 “Feature Code List” in the File main menu. See the figure below.

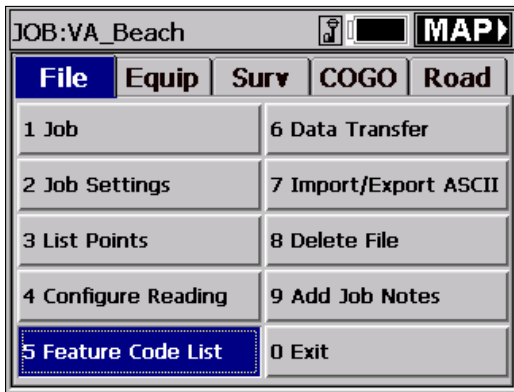

After you select 5 Feature Code List, the following Code List pop-up box is displayed. See the figure below.

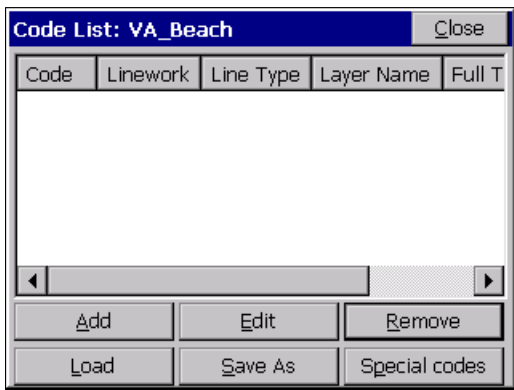



FCL (Feature Code List) files can be created, edited or reviewed on a PC using Carlson X-Port or any Carlson Surveying office software. (SurvPC's FCL file is equivalent to Carlson's Field-to-Finish FLD Table used in their PC office software. Transfer all PC Field-to-finish FLD table files using SurveyCOM or Carlson Export. Select the Field Code Table option to upload the FLD file to SurvPC as a FLC file.)

### Defining Field Code Line/Layer Properties

To define codes with line/layer drawn features and, optionally, GIS prompting, select in the Code List pop-up box "Add" (as shown in the previous figure). The following Add Code pop-up box allows the operator to define Field Code Line/Layer drawing properties.

- **Code:** Input one-word Field Code
- **Layer Name:** Defines the layer the linework 2D & 3D will draw in using Store Points
- **Full Text:** User defined full text description for code
- **Polyline On:** Yes or No defines to draw or not to draw between similar codes e.g. EP, EP1
- **Polyline is 3D:** Yes or No - Yes draws in 3D, No in 2D
- **New Attributes:** This highlights after inputting all the Line/Layer drawing properties

The following EP code has been input in the FCL file. When Surveying using Store Points in the Survey menu, inputting field codes EP, EP1, EP2 and so on will draw 3D Polylines between these similar codes in the EOP layer. A 3D Polyline will be drawn in real-time when collecting data and inputting EP or EP# codes in Surveyed points descriptions.

As mentioned above, "New Attributes" becomes highlighted after inputting all the Line/Layer drawing properties. GIS prompting information can be added for this field code. If no GIS prompting is applicable for this field code, simply pick OK and create another field code, or exit and store the FCL file.



The 'Add Code' dialog box has a title bar with 'Add Code', 'OK', and 'Cancel' buttons. It contains the following fields and controls:

- Code:** A text box containing 'EP'.
- Layer name:** A text box containing 'EOP'.
- Full Text:** A text box containing 'Edge of pavement'.
- Polyline On:** A dropdown menu with 'YES' selected.
- Polyline is 3D:** A dropdown menu with 'YES' selected.
- New Attributes:** A button at the bottom of the dialog.

### Defining Field Code GIS Prompting

To add GIS prompting to a defined Line/Layer code, select “New Attributes”. This button can be seen in the above figure at the bottom of the dialog. The following GIS Feature pop-up box is displayed. See the next figure below. To define GIS prompting for the EP field code, select “Add” in the Feature dialog shown below. The next pop-up box that appears, titled New attribute, is then displayed (shown below, underneath the Feature dialog). The New attribute dialog creates GIS prompting.

The 'Feature' dialog box is on the left and the 'New attribute' dialog box is on the right.

**Feature Dialog:**

- Name:** EP
- Table:** A table with columns 'Attribute', 'Type', and 'Req.'. It is currently empty.
- Buttons:** Load, Edit, Add, Remove, Up, Down, Save.

**New attribute Dialog:**

- Name:** (Empty text box)
- Prompt:** (Empty text box)
- Default Value:** (Empty text box) with a 'Set' button.
- List Values:** Type: Char, Req.: No.
- Buttons:** Add, Remove, Up, Down, OK.



**Load** will load any existing Field Code GIS prompting for reuse. **Edit** reviews or revises existing GIS prompting. **Add** creates individual GIS prompting, as shown in the figure immediately above (New attribute dialog). **Remove** deletes any highlighted GIS attribute. **Up and Down** reorders the sequence of GIS attribute prompting. **Save** stores input or edited GIS prompting and exits to Line/Layer drawing properties.

### Defining GIS Prompting

- **Feature Code Name:** No spaces GIS title for database
- **Codes:** Special codes, e.g. Date, Time, Lat, Long.
- **GIS Prompt:** Including spaces full name for GIS
- **Default Value:** Most common GIS value/default value
- **Set:** Lets the operator highlight and select the default value if there is a List of attribute Values.
- **Type:** Offers 4 options CHAR, INT, REAL and Code. Code Type will default to character type corresponding to special Codes. Codes can be Char, Int. or Real automatically.
- **Req:** Requisite/required entry. Operator cannot leave any GIS prompt empty when this field is set to Yes.

To add GIS attribute prompting for List Values, select the “Add” button within the New attribute dialog, as shown immediately below. The figure below that shows the New value pop-up box. The operator inputs, after selecting Add again, for each possible material (e.g. macadam, concrete, brick, stone cobbles and so on).

The image shows two side-by-side screenshots of software dialog boxes. The left dialog box is titled "New attribute" and has a "Cancel" button in the top right corner. It contains the following fields: "Name:" with the text "MATERIAL" and a "Codes" button to its right; "Prompt:" with the text "Road Surface"; "Default Value:" with a "Set" button to its right; and "List Values:" with "Type:" set to "Char" (via a dropdown menu) and "Req.:" set to "No" (via a dropdown menu). At the bottom of this dialog are five buttons: "Add", "Remove", "Up", "Down", and "OK". The right dialog box is titled "New value" and has a "Cancel" button in the top right corner. It contains a list box with the text "MATERIAL" at the top and "Macadam" below it, which is highlighted. An "OK" button is located at the bottom right of this dialog.

The data input for all GIS List Values is shown in following figure below. Note that Macadam is highlighted and will be the default value. If there are more than six attribute List Values, scroll bars will appear. This defines only one GIS entry Material for the EP field code. Each GIS prompt for the field code EP (e.g. Material, Location, Condition, Width, Slope and so on) will require being created using Add in the Feature pop-up box, as shown earlier in this tutorial.



**New attribute** Cancel

Name: MATERIAL Codes

Prompt: Road Surface

Default Value: Macadam Set

List Values: Type: Char Req.: No

- Macadam
- Concrete
- Brick
- Cobbled Stones

Add Remove Up Down OK

Add, Remove, Up and Down pertain to GIS List Values prompting. Add and Remove create or delete List Values entries. Up or Down reorders the highlighted List Value up or down. OK exits the GIS prompting screen retaining the GIS prompting entries and Cancel exits and discards all new inputs. The completed GIS field code for EP is shown below in the Feature dialog.

**Feature** Close

Name: EP

Attribute	Type	Req.
MATERIAL	Char	No
LOCATION	Char	Yes
CONDITION	Char	Yes
WIDTH	Char	Yes
SLOPE	Char	No

Load Edit Add Remove

Up Down Save

With all of the GIS Features input – Material, Location, Condition, Width and Slope – the operator can now select Save to store the GIS prompting for the field code EP. When storing points in the Survey menu in Store Points with EP or EP#, 3D linework when ended will prompt for EP GIS data as defined here. If 2D or 3D linework is created the GIS data will be attached to the linework. Note that Location, Condition and Width are required input GIS fields. Load allows selecting any existing field codes GIS prompting for reuse. Edit reviews or revises existing GIS prompting. Remove deletes highlighted GIS attribute prompting. The Up and Down buttons will reorder GIS attribute prompting. Save stores and exits.

### Importing & Exporting GIS Information from SurvPC





SurvPC imports and exports ESRI SHP files. SurvPC solely uses ESRI SHP files to interface with all GIS programs. ESRI SHP files are open architecture and are a widely used and accepted GIS format for most common GIS packages. To import or export GIS data to or from SurvPC, select in MAP – File – SHP File – Import or Export SHP File (Quick Import or Export only reads and writes the drawing entities and doesn't include the GIS info). There are two figures later in this tutorial that depict this.

### SurvPC Creates Three ESRI GIS Drawing Objects: Points, Arcs (Polylines) and Polygons (Closed Polylines)

There are only three types of drawing entries in ESRI SHP files points, arcs (open 2D or 3D Polylines) and polygons (closed 2D or 3D Polylines). The EP field code creates points and arcs and/or polygons. GIS information is stored only to the arcs or polygons and not the EP points. All GIS information for EP will be attached to the 3D Polylines. The second Field Code UP in the FCL job file creates points only with no linework. The UP field code attaches GIS information to the UP points. See the next two figures below.

The image shows two side-by-side screenshots of software dialog boxes. The left dialog is titled 'Feature' and has a 'Close' button. It contains a 'Name:' field with the value 'ep'. Below this is a table with three columns: 'Attribute', 'Type', and 'Req.'. The table has four rows: 'UP\_NO' (Char, Yes), 'HGT' (Char, No), 'CONDITION' (Char, Yes), and 'COMMENTS' (Char, No). At the bottom of the dialog are buttons for 'Load', 'Edit', 'Add', 'Remove', 'Up', 'Down', and 'Save'. The right dialog is titled 'Add Code' and has 'OK' and 'Cancel' buttons. It contains a 'Code:' field with the value 'UP' and a 'Layer name:' field with the value 'UTILITY'. Below these is a 'Full Text:' field with the value 'Utility Pole'. There is a 'Polyline On:' dropdown menu with 'NO' selected. At the bottom is a 'New Attributes' button.

Attribute	Type	Req.
UP_NO	Char	Yes
HGT	Char	No
CONDITION	Char	Yes
COMMENTS	Char	No



## Save Feature Code List File

With two field codes (EP and UP) with GIS information input and stored, using option 5 “Feature Code List” (in the File main menu), let’s collect some Survey data in Store Points with GIS information. First, Save As these two codes into a Feature Code List file, as shown below.

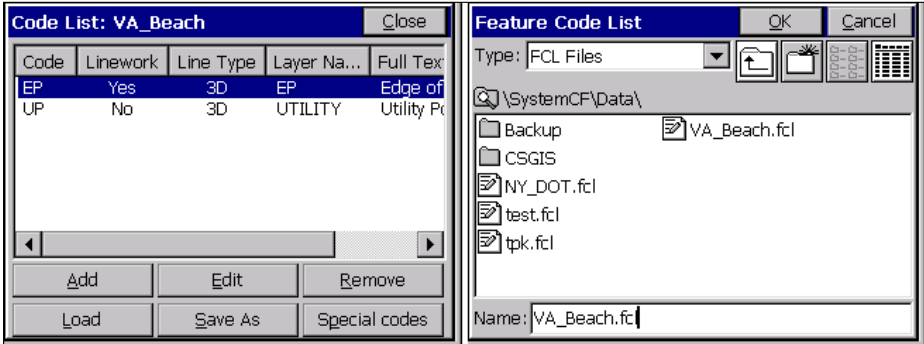

The Add and Edit buttons create or revise Line/Layer drawing properties and GIS prompting. Remove deletes field codes highlighted. Load unloads the current FCL file and loads another existing FCL Field Code List.

## Collecting & Storing GIS information in SurvPC

To demonstrate collecting Survey data with GIS information, SurvPC is set to either Manual Total Station or GNSS Simulation.

For Manual Total Station, go to the menu Survey – Store Points (see the next two figures). Follow the figures for Manual Total Station. It is important, in the main menu, that File – Configure Reading – HGT/Desc Prompt on Save is toggled ON!

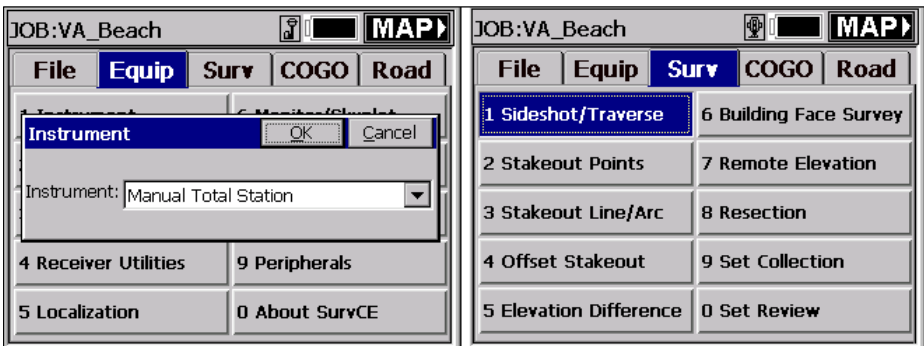



For GNSS Simulation, go to the menu Survey – Store Point (see the next two figures) and follow figures for GNSS Simulation.

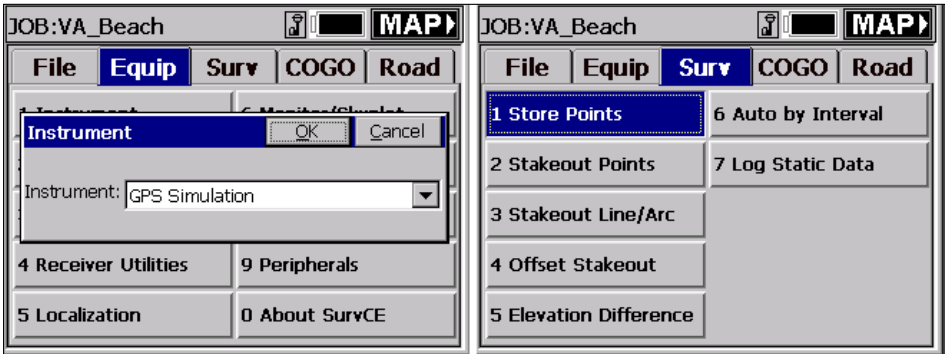

See these Manual Total Station example screen captures, shown here in the next four figures.

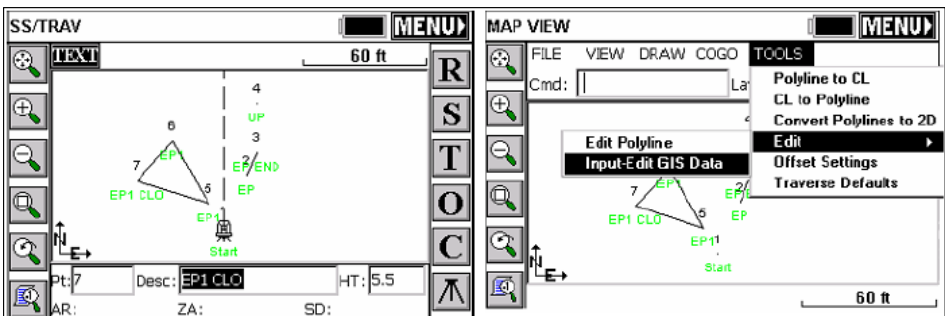
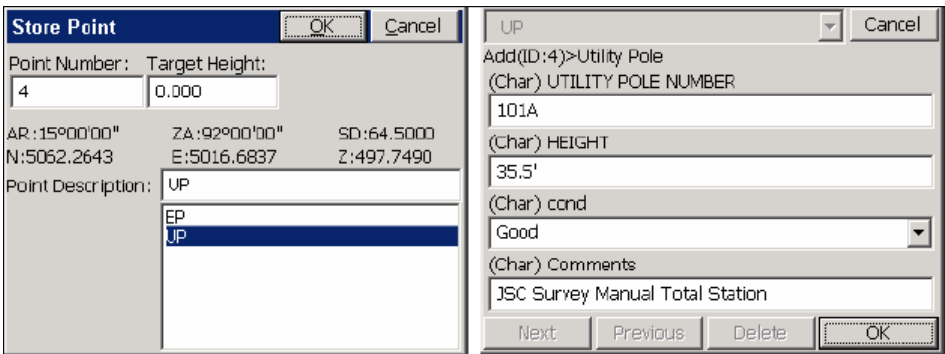



GNSS Simulation screen capture examples are shown in these next four figures.

Store Point			Store Point		
Point Number:	Target Height:		Point Number:	Target Height:	
3	3.281		3	3.281	
N:5073.2243	E:5030.9588	Z:96.7679	N:5073.2243	E:5030.9588	Z:96.7679
HRMS:0.045	VRMS:0.087	PDOP:3.200	HRMS:0.045	VRMS:0.087	PDOP:3.200
Point Description:	EP		Point Description:	EP END	
	EP			EP	
	UP			UP	

EP	Cancel
Add(ID:1036452394)>Edge of pavement	
(Char) Road Surface	
Macadam	
(Char) Location - Street Numbers Name	
(Char) Condition	
Good	
(Char) Measured Width	
Next	Previous
Delete	OK

EP	Cancel
Add(ID:1036452394)>Edge of pavement	
(Char) Road Surface	
Macadam	
(Char) Location - Street Numbers Name	
115 to 175 Robin Road	
(Char) Condition	
50% Good 25% Bad 25% Fair	
Excellent	
Good	
Fair	
Bad	

The sequence of shoots started with GNSS Simulation storing points 2 and 3 as EP codes. Point 3 was stored as EP END. A 3D Polyline was drawn between 2 to 3 and GIS prompting popped-up after point 3 was stored shown above. Note in the Condition field the operator input data not found in the default settings. Point 4 was stored using manual total station as a UP point code. Point 4's UP GIS prompting appeared after point 4 was stored. Points 5 through 7 were stored as a closed polygon. This was done by storing point 7 as EP1 CLO to close back to the start point 5 of the EP1 3D Polyline. The GIS prompting appeared for EP1 (not shown) and entered. The last sequence above was to exit Store Points and select MAP.



### Editing GIS Information on Arcs and Polygons – Input-Edit GIS Data

To edit existing GIS information stored on Arcs (2D/3D Polylines) or Polygons (closed 2D/3D Polylines) in the MAP pop-up box, select Tools – Edit – Input/Edit GIS Data, and pick any polyline or polygon. There are two figures below. The top figure shows how the closed 3D Polyline between points 5, 6 and 7 was selected using this command. GIS data for the closed 3D Polygon is shown in the second figure.

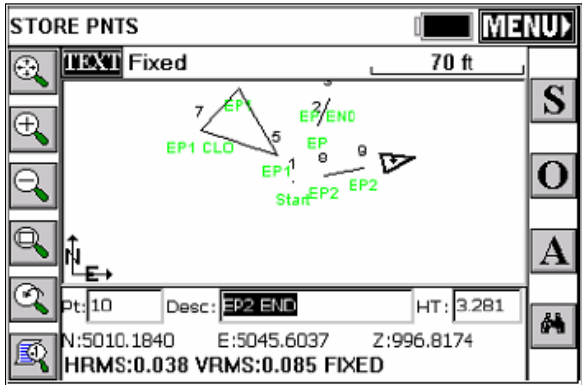

The above figure displays the next EP code EP2 stored using GNSS Simulation. When ended with a END or CLO description after EP2 SurvPC will prompt for EP GIS data to attach to the polyline as defined above.

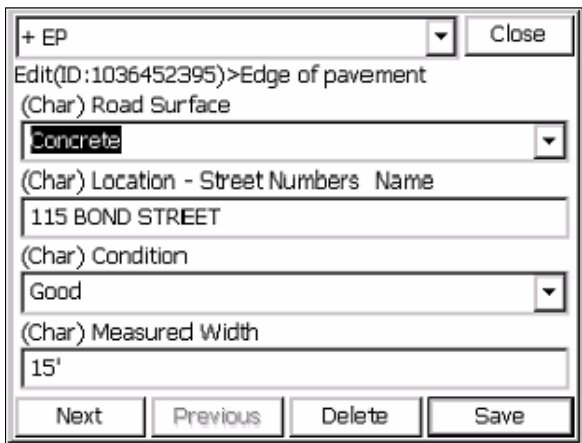

The figure above displays the ease of reviewing, creating or editing GIS data using Input-Edit GIS Data. From the MAP screen Input-Edit GIS Data was selected and the closed 3D Polyline picked on the screen. The GIS data stored prior was displayed for review or editing. Any data point, polyline or closed polyline could be selected using the Input-Edit GIS Data command in MAP and new GIS attached to this entity or existing GIS data reviewed and edited.



## Editing GIS Information on Points using List Points

Input-Edit GIS Data only works creating, reviewing or editing GIS information on Arcs or Polygons. To create, review or edit GIS information on points use List Points shown below under File – 3 List Points.

The screenshot shows the software interface with the 'List Points' menu option selected. The table below lists the points:

Pt ID	Northing	Easting	Elevation	Description	Pt IC
1	5000.00	5000.00	500.000	Start	1
2	5026.71	5011.29	996.722	EP	2
3	5038.22	5016.16	996.817	EP END	3
4	5062.26	5016.68	497.749	UP	4
5	5012.99	4992.50	105.000	EP1	5
6	5043.29	4975.00	104.127	EP1	6
7	5024.50	4957.57	104.145	EP1 CLD	7
8	5002.85	5014.01	996.801	EP2	8
9	5006.51	5032.35	996.807	EP2	9

Highlight point 4 and select Edit (see figure immediately above). Point 4 is the only Surveyed number with GIS data stored to the point. The Edit Point pop-up box appears and can be seen in the next figure below. To create, review or edit GIS information select Input/Edit Attributes (See Figure 9-32).

*Note: At the +UP box on top the down - arrow can be selected and one or more GIS field codes could attach GIS data to this same point. Points, Arcs or Polygons can all have one or more GIS field codes attached to these entities.*

The 'Edit Point' dialog box is shown with the following fields and options:

- Point ID: 4
- Northing: 5062.2643 ft
- Easting: 5016.6837 ft
- Elevation: 497.7491 ft
- Description: UP
- Buttons: Input/Edit Attributes, OK, Cancel

The right side of the dialog shows the GIS attributes for the selected point:

- + UP (dropdown menu)
- Edit(ID:4)>Utility Pole
- (Char) UTILITY POLE NUMBER: 101A
- (Char) HEIGHT: 35.5'
- (Char) cond: Good
- (Char) Comments: JSC Survey Manual Total Station
- Buttons: Next, Previous, Delete, Save



## Exporting SurvPC GIS Data as ESRI SHP files

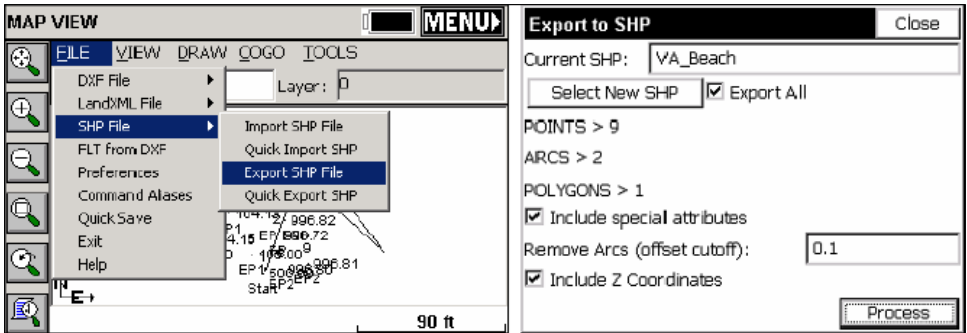

These final two figures, above, display the exporting of our VA\_Beach MAP and GIS data. The ESRI SHP file consists of 9 points, 2 arcs and 1 polygon (closed polyline). Only one point, point 4, has UP GIS data. Two arc polylines and one polygon have EP GIS information attached. Note that Include special attributes is checked. This adds to polyline arcs and closed polygons the polylines length and area to the GIS data automatically. Process with Export All checked stores the VA\_Beach three SHP files automatically to a user defined subdirectory and a fourth SHP file with 8 points without GIS data.



## 10.4 Tutorial 4: Standard Procedures for Conducting GNSS Localizations

This tutorial is intended to assist users with the recommended localization method for SurvPC. Other methods can be used and it is up to the individual users to determine which is best for them.

### File Extensions

Localization File: \*.dat

Geoid Model File: \*.gsf

Coordinate File: \*.crd

Raw Data File: \*.rw5

### **Projections**

It is essential that the proper plane coordinate projection is selected prior to creating a localization file. This should be the first step performed during the creation of the job file and be performed easily through File  Job Settings  GNSS.

### **Geoid Model**

An important item to note is if the user intends to use a geoid model (typical for localizations that contain less than 3 control points), the geoid model must be applied prior to the creation of the localization file.

A local portion of the geoid grid must be extracted from the Carlson Geoid Model using Carlson X-Port, SurvCOM, Survey or Civil/SurvCADD, and the geoid model file must be installed prior to the creation of the local geoid file. It is also highly recommended that the local geoid file grid size does not exceed 100 miles.

### **Web Link to the Geoid Files**

<http://update.carlsonsw.com/public/CarlsonGeoidGrids.exe>

### **Transfer or Enter the Known (local) Points**

It's a good idea to simplify the process by transferring the known (local) points to the PC prior to going to the field. Conversely, the user can keyboard enter the known coordinates for these points into the CRD file, one at a time, using File  List Points  Add. It is not recommended that the user keys in the local coordinates from within the localization process as transpositions can occur easily. However, this can be done as well.

### **Collect the GNSS Locations with Averaging**

Using the Survey/Store Points routine, specify your point ID. It is good to use something that will relate to the original known point. Example, if the known point for the first control point is 1, then you may want to collect the measured location as 1001. Use the average reading icon <A> to collect several epochs of data at each point. Typically, when using a 1 Hz receiver, 10 to 30 readings will be collected to ensure that the RTK solution is consistently reporting the same position for 10 to 30 seconds. On a 5 Hz receiver, the user may want to collect 50 or more readings as 50 readings would be 10 seconds.





## Create the Localization File

Once the PC has points that represent the known (local) coordinates and the measured data for these points, the localization file can be created.

Select Equip → Localization → Add to enter each point into the localization file.

## Local Point

The first dialog presented to the user will be the Local Point dialog shown below. Enter the known (local) coordinate point ID or coordinates. If the point does not exist in the CRD file and coordinates are entered into this dialog, do not enter a point ID. Select OK when the known (local) position has been defined.

**Local Point**

OK Cancel

Please enter local coordinate values.  
You may use a point number from  
the current or control job.

Point From File: 1

Local Northing: 5000

Local Easting: 5000

Local Elevation: 100

Figure 10: GNSS Coordinates

The next dialog presented will be the GNSS Coordinates dialog shown below. Since the measured locations for each point has already been recorded, the user will want to use the option From Raw File in this dialog. Select OK to continue.

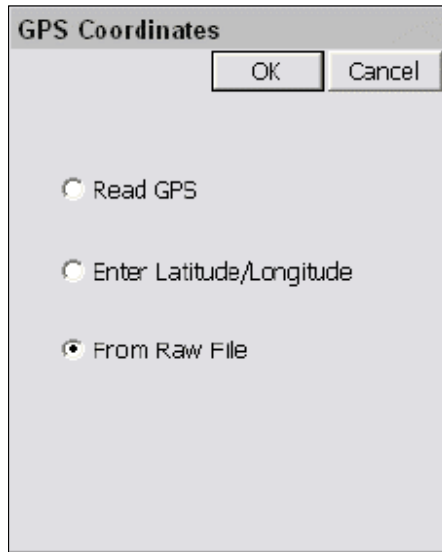

**Figure 11: Surveyed Point**

Next, the user will be presented with the Surveyed Point dialog shown below (top image). This dialog allows the user to select or enter the GNSS measured point that represents the known (local) point. If the user selects the GNSS measured point using the list icon, they should ignore the current coordinates displayed in the List Points dialog shown below (bottom image), as they only reflect the non-localized position at this point. The important thing to remember is that if the local point was 1, and the GNSS measured point was 1001, the user must enter 1001 in this dialog.



Surveyed Point		List Points			
Please enter a point number from the current or control job for which raw data exists.		Settings	Find	OK	Close
Point From File:	<input type="text" value="1001"/>	Pt ID	Northing	Easting	Elevati
		* 1	5000.0000	5000.0000	100.00
		* 1001	5017.9607	5007.5937	93.479

### Save the Localization File

Once all of the points have been added to the localization dialog, save the localization file before exiting using the Save button.

### Reprocess Raw File and Update Coordinates

At this point, all of the coordinates in the CRD file that represent the measured positions need to be updated to reflect the newly created localization. To do this, select COGO  Process Raw File and process the raw file through the localization file. This will update the previously measured GNSS points. Verify that the positions look valid by viewing the points in File  List Points. You should be able to compare the known and measured positions to see if they look right. Depending on the localization method, the measured values may not be exactly the same as the original known positions due to error that may have existed in the original positions.

### Additional GNSS Measurements

Once the localization is defined, all of the GNSS points measured after its creation will be recorded to the CRD file based on this localization.

### Changing the Localization

If the user determines that they want to redefine the current localization during a job, they must reprocess the entire raw file after making any changes to the localization file. It may be prudent to simply define a new localization file from scratch, leaving the original intact, and reprocess the raw file through this new localization file. Just remember that the last localization loaded, will be the current localization.



## Selecting Projections for use in Localization

Whenever you select a projection or coordinate system, you can place it in a “most used” list of coordinate systems to choose from under the GNSS tab in Job Settings. This list can contain one projection system or many different systems the user selects.

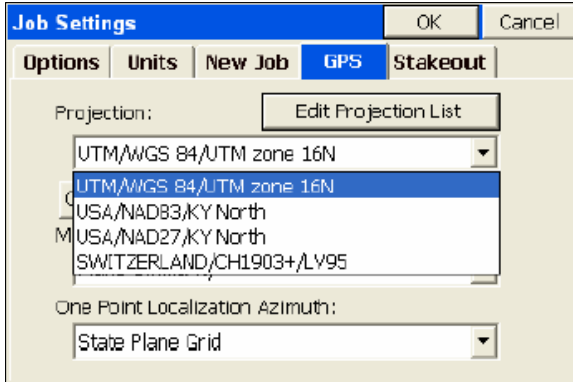

This is a special list of either predefined (e.g. KY North NAD83) or user-defined coordinates systems. To get the list started or add to the list, select Edit Projection List and click Add Predefined. In the U.S., for example, surveyors might want to keep the UTM (WGS84) system plus the NAD83 and NAD27 “state plane” zones in the list for quick access, covering the region of your work. European and other worldwide zones can be added. When setting up a UTM selection, you can choose your zone, referencing the graphic below for the US:

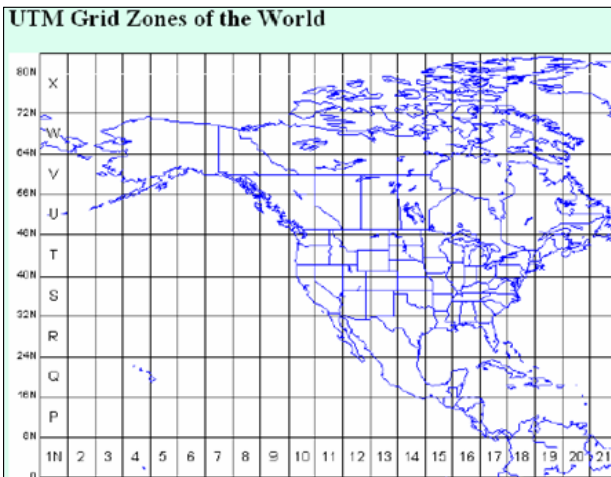

You can see a map of the UTM zones online at:  
<http://www.dmap.co.uk/utmworld.htm>



To edit the list of saved projections, click on Edit Projection List. Here we select a user-defined UTM system from the list to Delete or Edit.

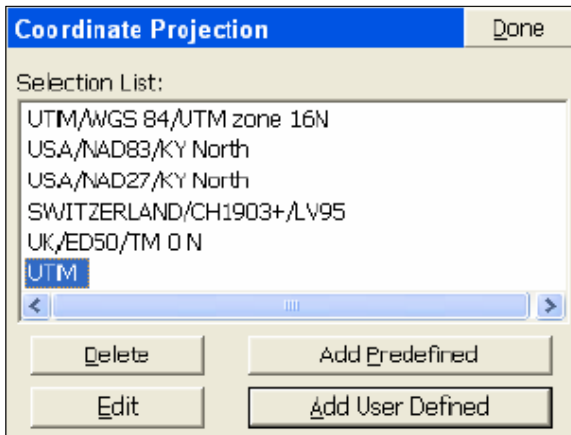

Choosing Edit will bring you to the screen below:

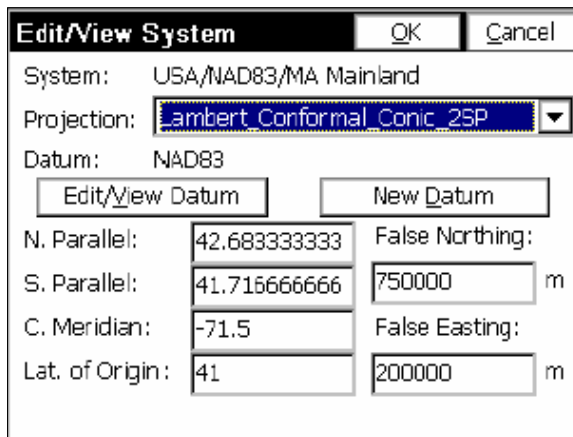



From this screen, you can select the Projection calculation method as well as calculation parameters. Projections include:

- Lambert Conformal\_Conic\_2SP
- Transverse\_Mercator
- Oblique\_Stereographic (Double)
- Lambert\_Conformal\_Conic\_1SP
- Oblique\_Mercator\_83,
- Stereographic Oblique\_Mercator\_27,
- Transverse\_Mercator\_OSTN02
- Oblique\_Stereographic\_RD2000
- Oblique\_Mercator
- Cassini\_Soldner
- Transverse\_Mercator\_27
- Lambert\_Conformal\_Conic\_27
- Transverse\_Mercator\_Alaska\_27
- Transverse\_Mercator\_34

You may also use the buttons on this screen to edit the existing datum or create a new datum definition.

**Define Coordinate System**    OK    Cancel

Name: WGS84

Ellipsoid: WGS84~1

a: 6378137 m    Scale (ppm): 0

1/f: 298.257223562776

dX: 0 m    rot X: 0 °

dY: 0 m    rot Y: 0 °

dZ: 0 m    rot Z: 0 °

GSF File is relative to WGS84

The Datum definition screen is where you select the ellipsoid and Helmert parameters to apply.

If you select Add User Defined within the Coordinate Projection List screen, you proceed to the screen below:



New System		OK	Cancel
System:	MyNewSystem		
Projection:	Transverse_Mercator		
Datum:	<input type="button" value="Load File"/> <input type="button" value="New Datum"/>		
Scale Factor:	<input type="text" value="1"/>	False Northing:	<input type="text" value="0"/> m
C. Meridian:	<input type="text" value="0"/>	False Easting:	<input type="text" value="0"/> m
Zone Width:	<input type="text" value="6"/>		
Lat. of Origin:	<input type="text" value="0"/>		

Here you enter the name of the new system and select the projection type and parameters, or you can “Load File” to load a pre-defined system stored earlier (in the form \*.sys or \*.cs1).

Coordinate Projection		OK	Cancel
Type:	SYS Files	<input type="button" value="Up"/>	<input type="button" value="Down"/>
D:\EMULATORW32\survce\Release\data\			
AGD84HIGGINS.sys			
AGD84HIGGINS2.sys			
AGD84HIGGINS3.sys			
alaska1.sys			
AlaskaNAD83_1.sys			
Name: <input type="text"/>			



If you select “Add Predefined” to create a new, stored projection system, you will be presented with this screen:

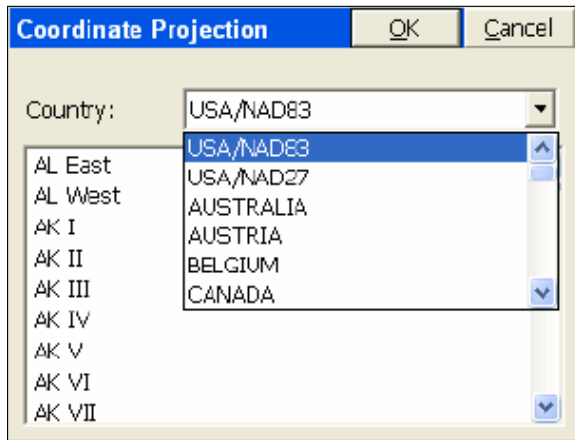

Here you can select the country and then the corresponding system for your area. There is a very extensive list of European and Asian systems including in the list. The “quick-access” short list of most used projections enhances job efficiency.





## 10.5 Tutorial 5: Performing a Compass Rule Adjustment

In the example below, as shown in the next figure, the traverse was performed by occupying point 1 located at the NW corner of the block. The initial backsight was established by azimuth, measured and stored as point 2 shown NW along the hanging leg. e.g. Angles and distances were measured in a clockwise direction. Point numbers 6 and 1 are at the same location and point numbers 7 and 2 are at the same location. This method allows for the closing of the angles and the measurement of all traverse legs.

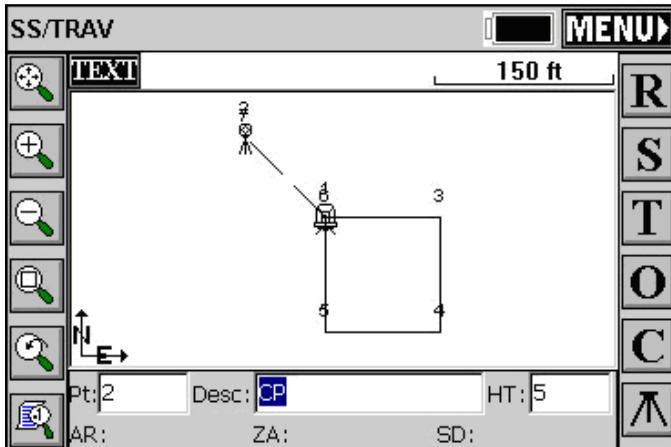

### Process Raw File

Select “Process Raw File” from the “COGO” tab, as shown below in this figure.

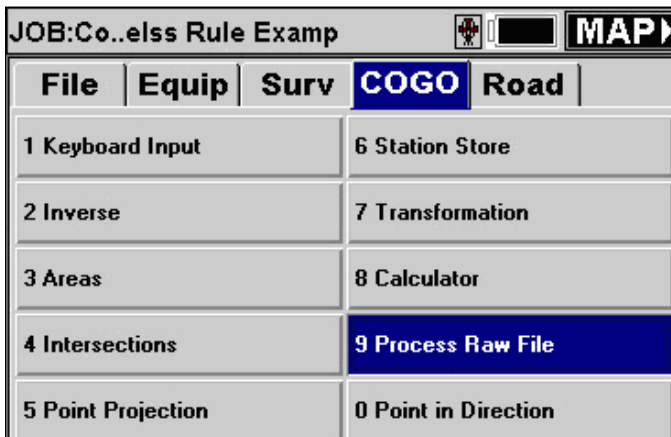



### Select Raw File

The next figure below shows the standard Windows file selection dialog. Select the RW5 file you want to process followed by the “OK” button.

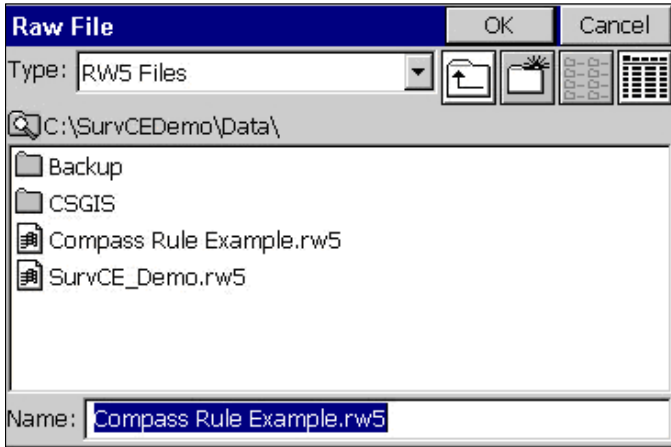

Select “Compass” from the adjustment options dialog box as shown in this figure below.

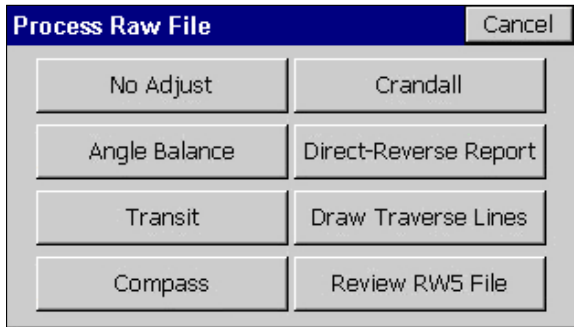



### Reference Closing Point

Key in the initial occupied point number for the “Reference Closing Point #:” and toggle on the “Apply Angle Balance” option, followed by the “OK” button, as shown in the next figure below.

**Process Raw Data Options**    OK    Cancel

Reference Closing Point #:

North:   Apply Angle Balance

East:   Vertical Error Adjustment

Elev:   Report Point Adjustments

Report Unadjusted Points

Report Sideshots

### Closed Traverse

In a closed traverse scenario, the reference closing point will always be your initial occupied point name.

*Note that you will need two known points, or one point and a known azimuth, for a closed traverse. The angle balance point will be the same location as the original backsight and will not be adjusted.*

### Open Traverse

In an open traverse scenario, the reference closing point will be a stored point name or coordinates that represents the known values for the last occupied point in the traverse. Note that you will need two known points, or one point and a known azimuth, at the beginning and at the end of an open traverse; one point at the end will be used to close on and other will be used for angle balance (when Angle Balance is applied). The angle balance point will be the same as the last foresight point in the traverse and will not be adjusted.



### Traverse Points

You'll notice in the Angle Balance Measurement figure below, since you keyed in the data yourself, that the number of traverse points in this survey is 7. Since point 7 was only measured to avoid and record the closing angle balance measurement by hand, in this example the traverse is only from points 1 through 6. Replace the 7 in the "Ending Point Number" input box with a 6, as shown in this next figure immediately below, followed by the "OK" button.

Note that point 6 should be the same location as point number 1 in a closed traverse.

Traverse Points		OK	Cancel
Starting Point Number :	<input type="text" value="1"/>		
Ending Point Number :	<input type="text" value="6"/>		

### Angle Balance

Select the foresight shot from the last occupied point to the original backsight location. In this example, we would select the leg measured from point 6 to point 7, since point 7 was our foresight angle balance shot to point 2. Press the "OK" button. In an open traverse, this would be the measured leg that represents the known azimuth or bearing at the end of the traverse.

Angle Balance Measurement		OK	Cancel
Select the Angle Balance Shot:			
Occupy Pt	Foresight Pt		
1	2		
1	3		
3	4		
4	5		
5	6		
6	7		



### Reference Closing Angle

Finally, we need to provide the reference closing angle (record). This is the original backsight azimuth. Key in point 1 and point 2, or key in the known azimuth or bearing, followed by the “OK” button.

In an open traverse, key in the stored point numbers that represent the values for the known control points at the end of the traverse, or key in the known azimuth or bearing. The adjustment report should be presented, and the adjustment should be complete. The angle balance point number 7 will not be adjusted to fit point number 2, and can be discarded.

**Reference Closing Angle**    OK    Cancel

Measured Closing Bearing:    N45°00'08"W

Measured Closing Azimuth:    314°59'52"

Angular Error:    -0.000800000

From Point:        To Point:   

Reference Closing Angle (dd.mmss):   

Format:

NE     SE     SW     NW     AZ



---

## 11 Troubleshooting

### 11.1 GPS Heights

SurvPC records GPS heights as the ellipsoid height, expressed in meters, at either the phase center or the ARP of the antenna, depending on the GPS manufacturer. If the position is recorded to the ARP, then the LS record (antenna height) will only reflect the user-entered value. If the position is recorded to the phase center, then the LS record (antenna height) will reflect the user-entered value plus the phase center offset.

### 11.2 Miscellaneous Instrument Configuration

#### **Leica Robotic - Do I need to be in RCS (Remote Control) mode?**

You must verify that you are NOT in RCS mode when using SurvPC with Leica robotic equipment. It will appear as though you are not communicating with the instrument if this mode is active. Refer to the Leica documentation for how to exit RCS mode.

#### **Leica GPS - What firmware will allow radio channel changing?**

Firmware version 3.52 or later is required for SurvPC to have radio channel changing functionality.

#### **Geodimeter 600 - What firmware version is required?**

Firmware version 696-03.xx or later is required for SurvPC to operate with this instrument. To check the firmware on the instrument, follow the key strokes: Menu, 5, 4, 1. The Geodimeter 640, for example, does not take measurements in reverse face. Therefore, when doing D&R, set reverse face to angle only.

#### **Sokkia GSR 2700 IS - What do I do when I get the Bluetooth pass key prompt?**

This receiver does not require a pass key. If you are prompted for one, do a factory reset on the receiver by holding the power key down until the message displayed is Factory Reset. Then turn the device off and back on again. In Carlson SurvPC, clear the receiver from the Bluetooth connections list and add it back in.



## 11.3 Supported File Formats

What file types does SurvPC use or convert?

- **ALI** ISPOL Centerline File (Spain)
- **ALN** TerraModel Road Alignment File
- **ALZ** Form of CLIP Vertical Alignment File (Spain)
- **ASC** ASCII text file for point imports or Inroads Centerline File
- **CL** Carlson Horizontal Road Alignment File
- **CR5** TDS Binary Coordinate File
- **CRD** Carlson coordinate file in binary form.
- **DAT** Carlson Localization File
- **DXF** Drawing file format that can be used for exchanging drawings.
- **EGM** Carlson EGM Geoid File
- **FCL** Carlson Field Code Library file.
- **FFF** Older form of Caice Cross - section File
- **FLT** Carlson Triangulation Mesh File
- **G99** Carlson Geoid99 File
- **GRD** Carlson Grid File
- **GSI** Leica file extension for Raw files, Roading files, etc.
- **INF** Carlson User Preferences Settings File
- **INP** MOSS Roading Files (Horizontal and Vertical Alignment)
- **LIS** Form of IGRDS Cross - section File
- **NOT** Carlson Note File
- **OBS** Geodimeter Coordinate File
- **OSD** A form of Geopak Centerline File
- **PLT** Horizontal Alignment Report file from CLIP (Spain)
- **POS** Sokkia or Trimble Coordinate File
- **PRO** Carlson Vertical Road Alignment File
- **RAS** ISPOL Vertical Road Alignment File (Spain)
- **RD5** TDS Road Alignment File
- **RDS** IGRDS Cross - section File
- **REF** Carlson Base Station Reference File
- **RLN** TerraModel Road Alignment File
- **RW5** Carlson Raw Data File, TDS Raw Data File
- **SC1** ISPOL Cross - section File (Spain)
- **SCT** Carlson Cross - section File
- **SDR** Sokkia file extension for Raw Files, Roading files, etc.
- **SHP** ESRI Shape File
- **SUP** Carlson Road Superelevation File
- **TPL** Carlson Road Template File
- **TPT** Carlson Road Template Transition File
- **TRV** Traverse PC Coordinate File and CLIP Format for Sections (Spain)
- **XML** LandXML File may contain a variety of file types (e.g. Roading/DTM)
- **XRS** Form of Geopak Cross - section File



## 12 Raw Data

### 12.1 File Format

#### Carlson SurvPC RW5 Format

This section outlines the Carlson SurvPC RW5 format in detail. The format is a comma delimited ASCII file containing record types, headers, recorded data and comments.

The format is based on the RW5 raw data specification, with the exception of angle sets. Angle sets are recorded as BD, BR, FD and FR records to allow reduction of all possible data that can be recorded by Carlson SurvPC using the **Set Collection** routine. Essentially, these records are identical to a sideshot record.

With the exception of the aforementioned angle set records, if the RW5 specification is modified to provide enhanced functionality, the added or modified data will reside in comment records to avoid incompatibility with existing software. SurvPC writes latency in the GPS notes record of the RW5 file.

#### Backsight Record

Record type: BK

Field Header	Description
OP	Occupy Point
BP	Back Point
BS	Backsight
BC	Back Circle

Example:

*BK,OP1,BP2,BS315.0000,BC0.0044*

#### Job Record

Record type: JB

Field Header	Description
NM	Job Name
DT	Date
TM	Time

Example:

*JB,NMSAMPLE,DT06-27-2003,TM14:21:53*





### Line of Sight Record

Record type: LS

Field Header	Description
HI	Height of Instrument
HR	Height of Rod*

\*GPS heights may be recorded to phase center or ARP depending on GPS make.

Example(s):

*LS,HI5.000000,HR6.000000*

*LS,HR4.000000*

### Mode Setup Record

The mode setup will be recorded at the beginning of the raw data file.

Record type: MO

Field Header	Description
AD	Azimuth direction (0 for North, 1 for South)
UN	Distance unit (0 for Feet, 1 for Meter)
SF	Scale Factor
EC	Earth Curvature (0 for OFF, 1 for ON)
EO	EDM Offset (Inch)

Example:

*MO,AD0,UN0,SF1.00000000,EC1,EO0.0,AU0*

### Occupy Record

Record type: OC

Field Header	Description
OP	Point Name
N	Northing (the header is N space)
E	Easting (the header is E space)
EL	Elevation
--	Note

Example:

*OC,OP1,N 5000.00000,E 5000.00000,EL100.000,--CP*



### Off Center Shot Record

Record type: OF

<b>Field Header</b>	<b>Description</b>
AR	Angle Right
ZE	Zenith (actual)
SD	Slope Distance

Example(s):

*OF,AR90.3333,ZE90.0000,SD25.550000*

*OF,ZE90.3333,--Vert Angle Offset*

### Store Point Record

Record type: SP

<b>Field Header</b>	<b>Description</b>
PN	Point Name
N	Northing
E	Easting
EL	Elevation
--	Note

Example:

*SP,PN100,N 5002.0000,E 5000.0000,EL100.0000,--PP*



**Traverse / Sideshot Record / Backsight Direct / Backsight Reverse / Foresight Direct / Foresight Reverse**

Record type: TR / SS / BD / BR / FD / FR

	<b>Field Header</b>	<b>Description</b>
	OP	Occupy Point
	FP	Foresight Point
One of the following:		
	AZ	Azimuth
	BR	Bearing
	AR	Angle-Right
	AL	Angle-Left
	DR	Deflection-Right
	DL	Deflection-Left
One of the following:		
	ZE	Zenith
	VA	Vertical Angle
	CE	Change Elevation
One of the following		
	SD	Slope Distance
	HD	Horizontal Distance
	--	Note

Example (s):

*TR,OP1,FP4,AR90.3333,ZE90.3333,SD25.550000,--CP  
SS,OP1,FP2,AR0.0044,ZE86.0133,SD10.313750,--CP  
BD,OP1,FP2,AR0.0055,ZE86.0126,SD10.320000,--CP  
BR,OP1,FP2,AR180.0037,ZE273.5826,SD10.315000,--CP  
FD,OP1,FP3,AR57.1630,ZE89.4305,SD7.393000,--CP  
FR,OP1,FP3,AR237.1612,ZE270.1548,SD7.395000,--CP*



## GPS

Record type: GPS

Field Header	Description
PN	Point Name
LA	Latitude (WGS84)
LN	Longitude (WGS84, Negative for West)
EL	Ellipsoid elevation (in meters)
--	Note

\*GPS heights may be recorded to APC or ARP depending on GPS make.

Example(s):

*GPS,PN701,LA42.214630920,LN-71.081409184,EL-21.8459,--CP /Brass Disk*

### Alphabetical listing of Record Types

- BD** Backsight Direct
- BK** Backsight
- BR** Backsight Reverse
- FD** Foresight Direct
- FR** Foresight Reverse
- GPS** GPS Position in Lat (dd.mmss) Lon (dd.mmss) and WGS84 Ellipsoid Elevation in meters
- JB** Job
- LS** Line of Sight
- MO** Mode Setup
- OC** Occupy
- OF** Off Center Shot
- SP** Store Point
- SS** Side Shot
- TR** Traverse
- Note Record



## Alphabetical listing of Field Headers

<b>AD</b>	Azimuth Direction (0 for North, 1 for South)
<b>AL</b>	Angle-Left
<b>AR</b>	Angle-Right
<b>AZ</b>	Azimuth
<b>BC</b>	Back Circle
<b>BP</b>	Back Point
<b>BR</b>	Bearing (this field will be recorded as N123.4500W)
<b>BS</b>	Backsight (when back point is not defined)
<b>CE</b>	Change Elevation
<b>DL</b>	Deflection-Left
<b>DR</b>	Deflection-Right
<b>DT</b>	Local Date (MM-DD-YYYY)
<b>E</b>	Easting (the header is E space)
<b>EC</b>	Earth Curvature (0 for off, 1 for on)
<b>EL</b>	Elevation (GPS value is ellipsoid elevation in meters)
<b>EO</b>	EDM Offset
<b>FE</b>	Foresight Elevation
<b>FP</b>	Foresight Point
<b>HD</b>	Horizontal Distance
<b>HI</b>	Height of Instrument
<b>HR</b>	Height of Rod
<b>LA</b>	Latitude
<b>LN</b>	Longitude
<b>N</b>	Northing (the header is N space)
<b>OC</b>	Occupy Point Coordinates
<b>OP</b>	Occupy Point
<b>PN</b>	Point Name
<b>SD</b>	Slope Distance
<b>SF</b>	Scale Factor
<b>TM</b>	Local Time (HH:MM:SS)
<b>UN</b>	Distance Unit (0 for feet, 1 for meter, 2 for US feet)
<b>VA</b>	Vertical Angle
<b>ZE</b>	Zenith
<b>--</b>	Note



## 13 Index

Abbreviations.....	38
Action in Stakeout Mode Summary.....	29
Action in Topo Mode Summary.....	28
Alphabetical listing of Field Headers.....	697
Alphabetical listing of Record Types.....	696
Authorizing SurvCE.....	14
Battery Status.....	16
Carlson Cloud.....	30
Carlson Technical Support.....	16
COGO - Areas.....	387
COGO - Calculator.....	406
COGO - Intersections.....	389
COGO - Inverse.....	385
COGO - Keyboard Input.....	383
COGO - Manual Traverse.....	412
COGO - Point Projection.....	394
COGO - Station Store.....	399
COGO - Transformation.....	402
Cogo Menu.....	382
Color Screens.....	16
Contents.....	2
Customer Service, Technical Support, Repair:.....	16
End-User License Agreement.....	6
Equip - About SurvCE.....	122
Equip - Check Level.....	240
Equip - Configure (General).....	174
Equip - Configure (Sets).....	189
Equip - Configure (View).....	185
Equip - GPS Base.....	143
Equip - GPS Rover.....	152
Equip - GPS Setup.....	134
Equip - GPS Utilities.....	250
Equip - Localization.....	217
Equip - Monitor / SkyPlot.....	233
Equip - Peripherals.....	243
Equip - Tolerances.....	241
Equip - Total Station.....	124
Equip Menu.....	123
File - Data Transfer.....	113
File - Delete Job.....	121
File - Exit.....	122
File - Feature Code List.....	82
File - Import / Export.....	115



File - Job .....	40
File - Job Settings (Format) .....	46
File - Job Settings (New Job).....	42
File - Job Settings (Options) .....	48
File - Job Settings (Stake).....	60
File - Job Settings (System).....	44
File - Points.....	70
File - Raw Data.....	73
File Menu.....	39
GPS Raw Only.....	164
<i>GPS Raw Only - Closing the Logging File</i> .....	173
GPS Raw Only – Fully Kinematic Logging .....	171
GPS Raw Only – Stationary Logging.....	164
GPS Raw Only – Stop and Go Logging.....	168
Graphic Mode - List of ICONS.....	18
Hardware Notes .....	16
Hot Keys & Hot list .....	24
Hybrid+.....	197
Input Box Controls.....	33
Installation .....	10
Instrument Selection .....	32
Keyboard Operation.....	36
Listen – Listen .....	141
Map - Basics .....	560
Map - Cogo .....	627
Map - File .....	567
Map - Tools.....	641
Map - View .....	588
Map Menu.....	559
One-Button Measurement with Field Code: .....	280
Quick Calculator.....	23
Raw Data - File Format.....	692
Raw DataSection.....	692
Registration Page .....	15
Road - Centerline Editor .....	427
Road - Draw Centerline .....	431
Road - Draw Profile.....	435
Road - Draw Template.....	442
Road - Profile Editor.....	432
Road - Stake Road .....	495
Road - Stake Slope.....	473
Road - Template Editor.....	436
Road - Utilities.....	443
Road Menu.....	426
Survey - Auto By Interval.....	372
Survey - Elevation Difference.....	343



Survey - Grid / Face.....	351
Survey - Leveling.....	364
Survey - Log Raw GPS.....	379
Survey - Orientation (Advanced Occupation).....	261
Survey - Orientation (Backsight).....	257
Survey - Orientation (Instrument Setup).....	254
Survey - Orientation (Remote Benchmark).....	260
Survey - Orientation (Robotics).....	274
Survey - Remote Elevation.....	377
Survey - Resection.....	353
Survey - Set Collection.....	358
Survey - Stake Line / Arc.....	320
Survey - Stake Offset.....	338
Survey - Stake Points.....	304
Survey - Store Points (GPS Offsets).....	299
Survey - Store Points (GPS).....	290
Survey - Store Points (TS Offsets).....	286
Survey - Store Points (TS).....	276
Survey Menu.....	253
Total Station Prism Search by GPS.....	131
Troubleshooting - GPS Heights.....	690
Troubleshooting - Miscellaneous Instrument Configuration.....	690
Troubleshooting - Supported File Formats.....	691
Troubleshooting Section.....	690
Tutorial 1	
Calculating a Traverse (By Hand) with SurvPC-MIL.....	661
Tutorial 2	
Performing Math Functions in Carlson SurvPC-MIL Input Boxes.....	663
Tutorial 3	
Defining Field Codes, Line/Layer Properties & GIS Prompting.....	664
Tutorial 4	
Standard Procedures for Conducting GNSS Localizations.....	676
Tutorial 5: Performing a Compass Rule Adjustment.....	685
User Interface.....	17
Using the Manual.....	10
View Options.....	21
Web Link to the Geoid Files.....	676